









# FIVER

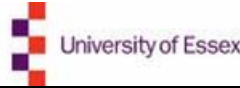

“Fully-Converged Quintuple-Play Integrated  
Optical-Wireless Access Architectures”

# FIVER partners

Num.	Beneficiary name		Short name	Country
1 (coord.)	UNIVERSIDAD POLITÉCNICA DE VALENCIA	 UNIVERSIDAD POLITÉCNICA DE VALENCIA	UPVLC	ES
2	PORTUGAL TELECOM INOVAÇÃO		PTIN	PT
3	CORNING		CORNING	FR
4	UNIVERSITY OF ESSEX		UESSEX	UK
5	THALES		TCF	FR
6	HTW-DRESDEN		HTW	DE
7	WROCLAWSKIE CENTRUM BADAN EIT+ sp. z o.o.		EIT+	PL
8	INSTITUTO DE TELECOMUNICAÇÕES		IT	PT
9	DAS PHOTONICS		DAS	ES

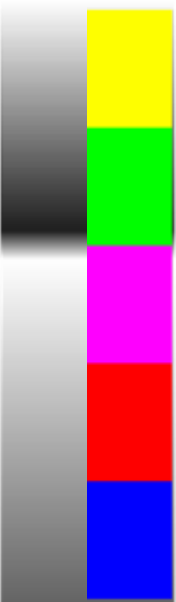

**FILVER**



# Rationale

# FTTH is (really) making its way

## Examples..

**July'08**→Alcatel-Lucent deploys first GPON-based FTTH network in Chile, July 2008

“deployment of the GPON (search for GPON) network will start in the third quarter of 2008, initially serving residential broadband user” [1]

**Sept'08**→Telefónica debuts Imagenio on FTTH network, 3-Sept 2008

“Spanish telco Telefónica has launched a triple-play service delivered via its new Fibre to the Home (FTTH) network in parts of the country within the fibre footprint, including a new package for its "Imagenio" IPTV service.” [2]

**Sept'08**→KDDI to launch 1Gbps fiber-optic service in October 2008

“upload and download speeds each of up to one gigabit per second (...) KDDI will charge 5,985 yen in basic monthly fees for Internet and telephone services (...) available only in six prefectures in the Kanto region and nearby Yamanashi Prefecture” [3]

FTTH currently supports “triple play” (3PLAY: high-speed data, telephony, TV)

Next-generation FTTH MUST:

1. SUPPORT “quintuple play” (5PLAY=4PLAY+security, 4PLAY=3PLAY+wireless)
2. PUSH forward BANDWIDTH × RANGE product
3. **INTEGRATE** optical and radio paths
4. BASED on standard Rx and Tx equipment to reduce deployment costs

[1] [http://lw.pennnet.com/articles/article\\_display.cfm?ARTICLE\\_ID=335664&p=13&section=ARTCL&subsection=none&c=XNEWS&p](http://lw.pennnet.com/articles/article_display.cfm?ARTICLE_ID=335664&p=13&section=ARTCL&subsection=none&c=XNEWS&p)

[2] <http://www.iptv-news.com/content/view/2289/64/>

[3] <http://www.japantoday.com/category/technology/view/kddi-to-launch-1gbps-fiber-optic-service-in-oct>

# FTTH networks are becoming complex..

## .. with is reflected in some limitations

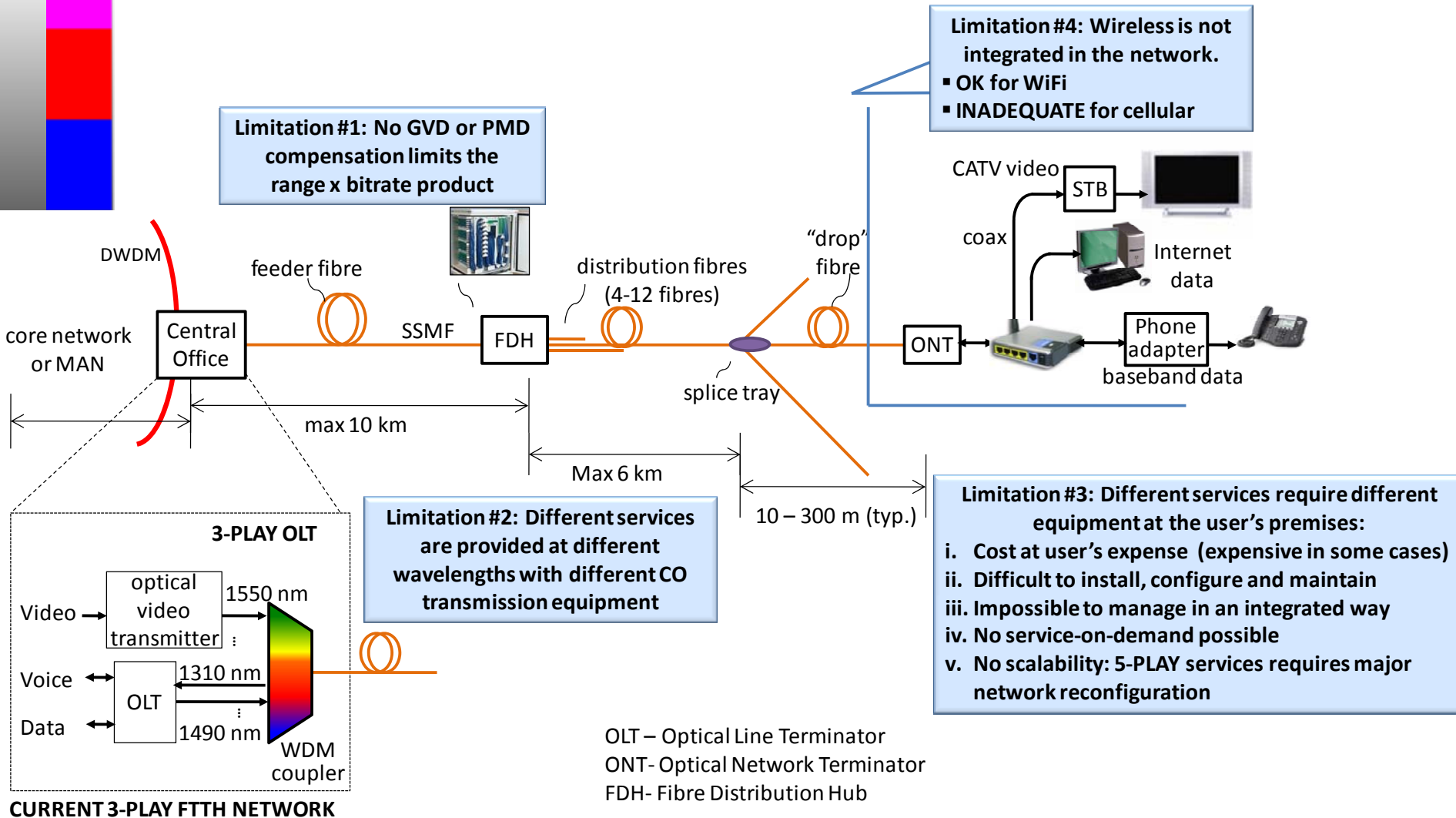
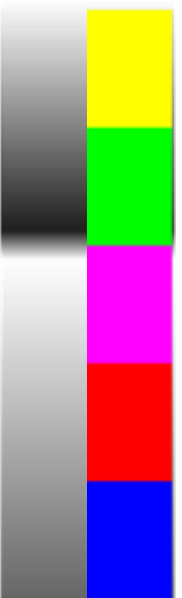

**CURRENT 3-PLAY FTTH NETWORK**

# OFDM is becoming a ubiquitous presence..

OFDM-based wired and wireless technologies survey (Sept 08)

## Wireless-

### ***Market-mature***

Wireless LAN: radio interfaces IEEE 802.11a, g, n (WiFi) and HIPERLAN/2

Terrestrial digital TV: DVB-T

Terrestrial mobile TV: DVB-H, T-DMB, ISDB-T and MediaFLO

### ***At market-introduction stage***

Wireless Personal Area Network (PAN) Ultra wideband (UWB) IEEE 802.15.3a (WiMedia-UWB)

Wireless MAN / Fixed broadband wireless access (BWA): IEEE 802.16 (WiMAX)

Mobile Broadband Wireless Access (MBWA): IEEE 802.20, IEEE 802.16e (Mobile WiMAX) and WiBro

Digital radio: DAB/EUREKA 147, DAB+, Digital Radio Mondiale, HD Radio, T-DMB and ISDB-TSB

### ***Emerging***

Mobile broadband 3GPP Long Term Evolution: High Speed OFDM Packet Access (HSOPA)

Cellular communication: Flash-OFDM

## Wired-

ADSL, ADSL+, ADSL2, VDSL broadband access via POTS copper wiring

Power line communication (PLC)

Multimedia over Coax Alliance (MoCA) home networking

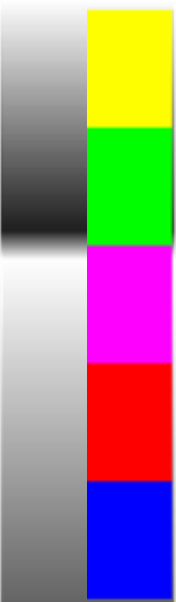

**FIVER**



# FIVER objectives



# FIVER general objectives:

1. **SUPPORT of 5-PLAY** services: Broadband internet data, phone/voice, high definition TV (HDTV), wireless (WiMAX, UWB and LTE femtocell) and home security/control services
2. **PUSH forward the BANDWIDTH × RANGE × USERS** product in a cost-effective way
3. **REDUCE OVERALL NETWORK FOOTPRINT:** STREAMLINED network architecture, REDUCE the real estate requirement (equipment size) and PUSH TO EFFICIENT OPTICAL TRANSMISSION AND LOW-EMISSION RADIO LEVELS, employing low power spectral densities, such as UWB
4. **REDUCE DEPLOYMENT AND OPERATIONAL COSTS:** The network must be based on standard transceivers (fully standard WiMAX, WiMedia-UWB and LTE are employed in FIVER) TO REDUCE INSTALLATION, MAINTENANCE AND EQUIPMENT ACQUISITION COSTS by the user
5. **GAIN NETWORK INTELLIGENCE:** CONVERGED METHODS must be introduced in order to enable a QUICK, ON-DEMAND, END-TO-END CENTRALISED network configuration

# ¿How to do this ?

1. **QUINTUPLE-PLAY OFDM-BASED FTTH+RADIO INTEGRATED ACCESS NETWORK**
2. **CONVERGED OFDM-baseband, medium-range WiMAX, short-range UWB and LTE femtocell** (a single compensation unit at the C.O.) transmission impairment compensation on...
3. **SAME OFDM MODULATION** along the **WHOLE PHOTONIC AND RADIO** paths:
  - A. **Data is distributed in OFDM–baseband** (down/up-stream)
  - B. **Video is distributed in WiMedia–UWB format (OFDM, downstream)**
  - C. Cellular **wireless is distributed in 802.16e Mobile WiMAX (OFDMA, down/up-stream) and LTE (OFDM down-stream)**
4. Optical-transmission impairments (**CROMATIC , POLARISATION and MODAL DISPERSION COMPENSATION** ) by a **SINGLE PROCESSING UNIT** at the OLT
5. Radio-transmission impairments (**MULTIPATH, NARROWBAND interference**) COMPENSATION
6. Enable **SINGLE MANAGEMENT** side-to-side along the FTTH access network of the **PHOTONIC AND RADIO ACCESS PATHS**
7. Demonstrate two network architectures: **CWDD (conventional)** and **R-EAT based (RWDD)**
8. Two network configurations:

**First (Y1 and Y2) covering UWB band (up to 10.6 GHz), in Y3 UWB at 60 GHz**

# FIVER 5-PLAY FTTH network

(A) Typical FTTH architecture

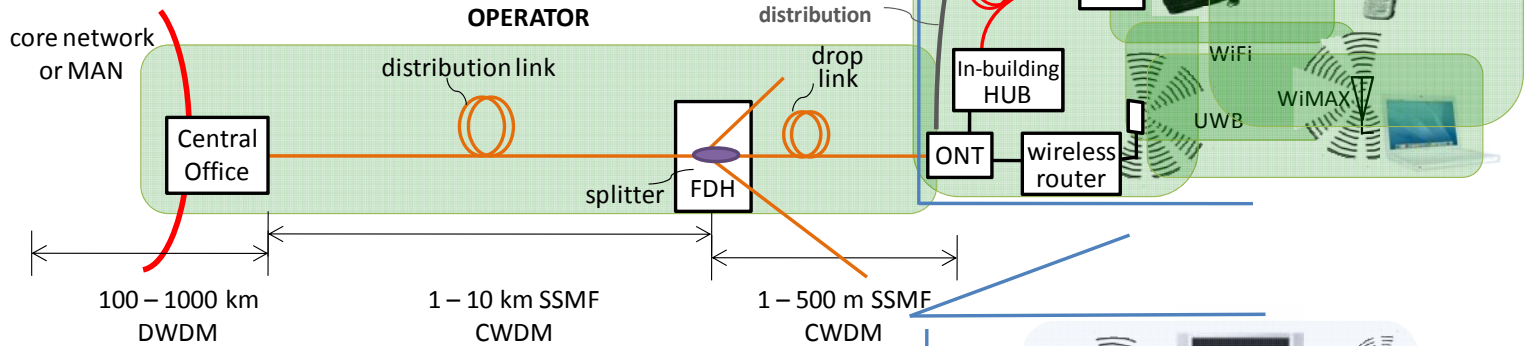

(B) FIVER integrated FTTH & in-building optical & radio

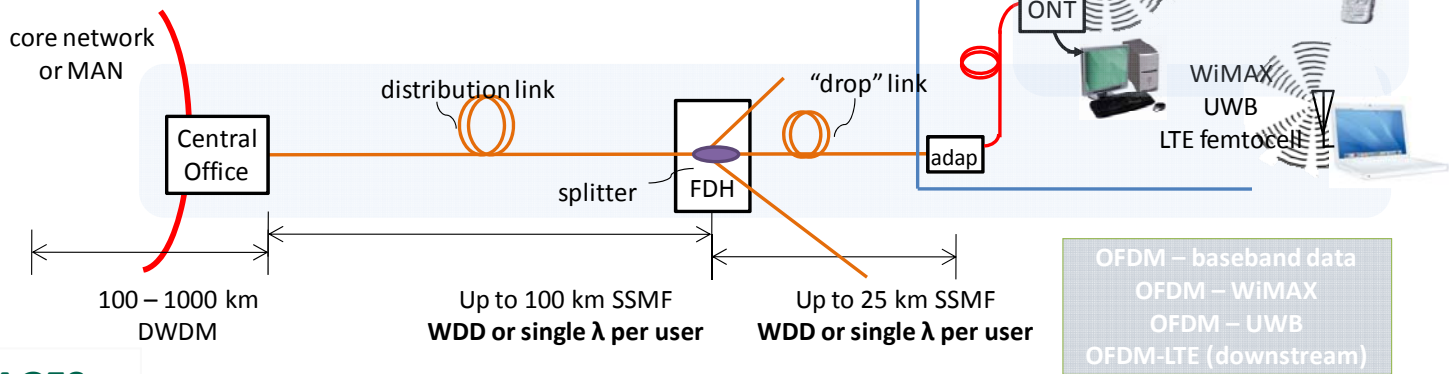

OFDM – baseband data  
 OFDM – WiMAX  
 OFDM – UWB  
 OFDM-LTE (downstream)

## KEY ADVANTAGES...

1. QUINTUPLE PLAY implemented using FULL STANDARD RECEIVERS (UWB, WiMAX, LTE and OFDM-baseband) employed at customer premises – ALL OFDM-BASED
2. Two architectures: CWDD: Conventional wavelength duplexing architecture  
 RWDD: R-EAT based (a single optical source at CO)
3. GVD, PMD, MMD compensated by a single DSP per user at CO
4. SIMPLIFIED ONU architecture





**FIVER**



## Some FIVER innovations

**Innovation:** FIVER conventional wavelength-division duplexed (CWDD) network architecture and the management strategy integrating optical and radio transmission (radio-over-fibre)

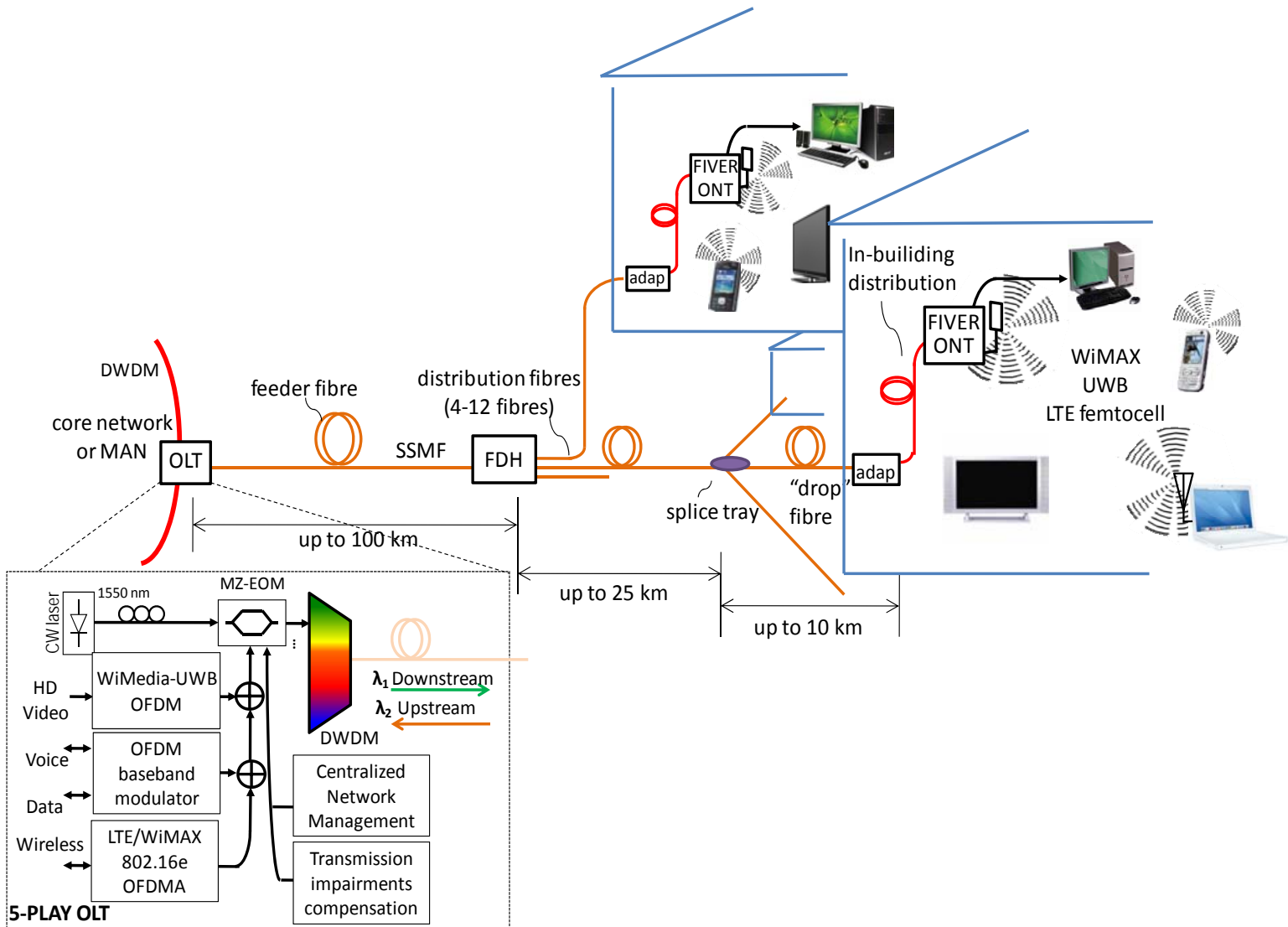

## Innovation: R-EAT based network architecture (RWDD)

- Improvement over the CWDD architecture
- Reflective-EAT based
- Leading partner: UESSEX

FIVER-ONT (RWDD)

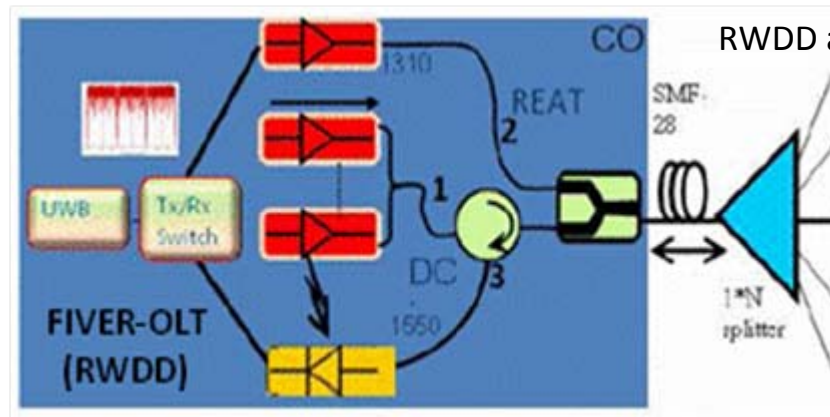
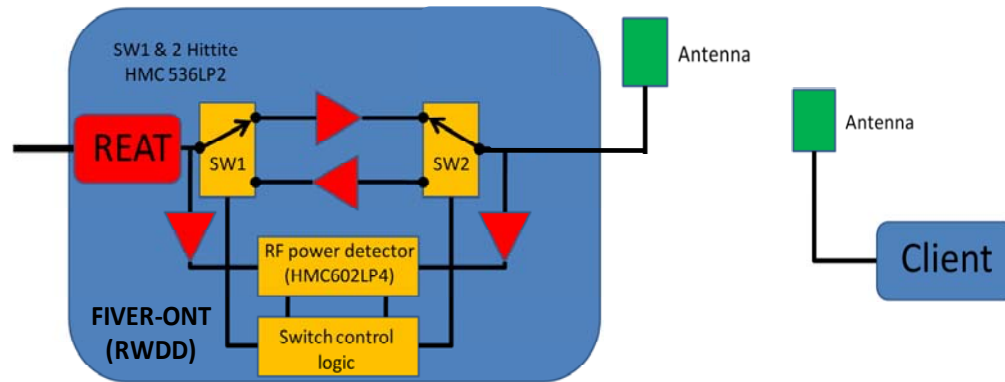

RWDD architecture (multiuser)

## Innovation: Coexistence of OFDM signals in optical transmission

- Coexistence of OFDM-baseband, WiMAX OFDMA, UWB-OFDM and LTE (DS)
- High spectral efficiency
- Flexibility: Future-proof for new OFDM-like based wireless standards
  - Lead partners: EIT+, UPV

(A) STEP 1: Integrated OFDM approach (1st stage of the project, Y2)

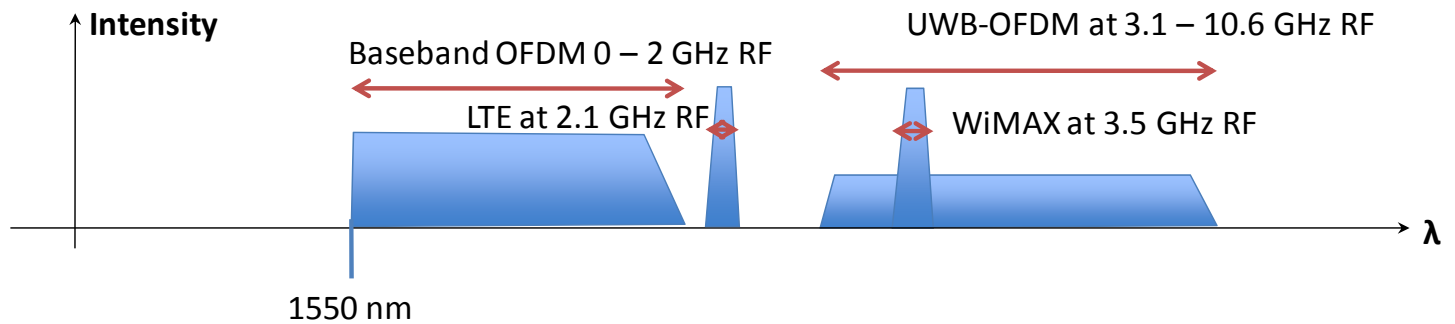

(B) STEP 2: Integrated OFDM approach with 60 GHz extension (2st stage of the project, Y3)

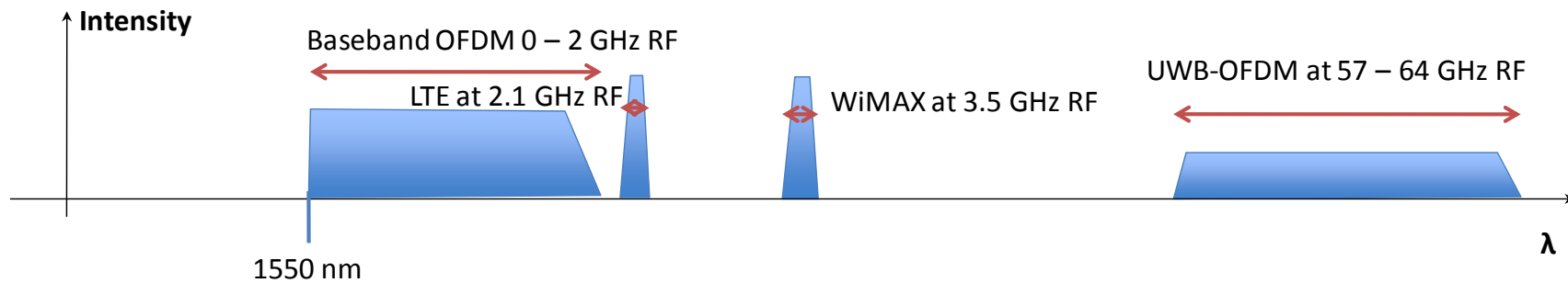

## Innovation: Coexistence of WiMAX, LTE and UWB in radio

- Detection and avoid mechanisms are investigated and applied on system level
- Central management of interference issues

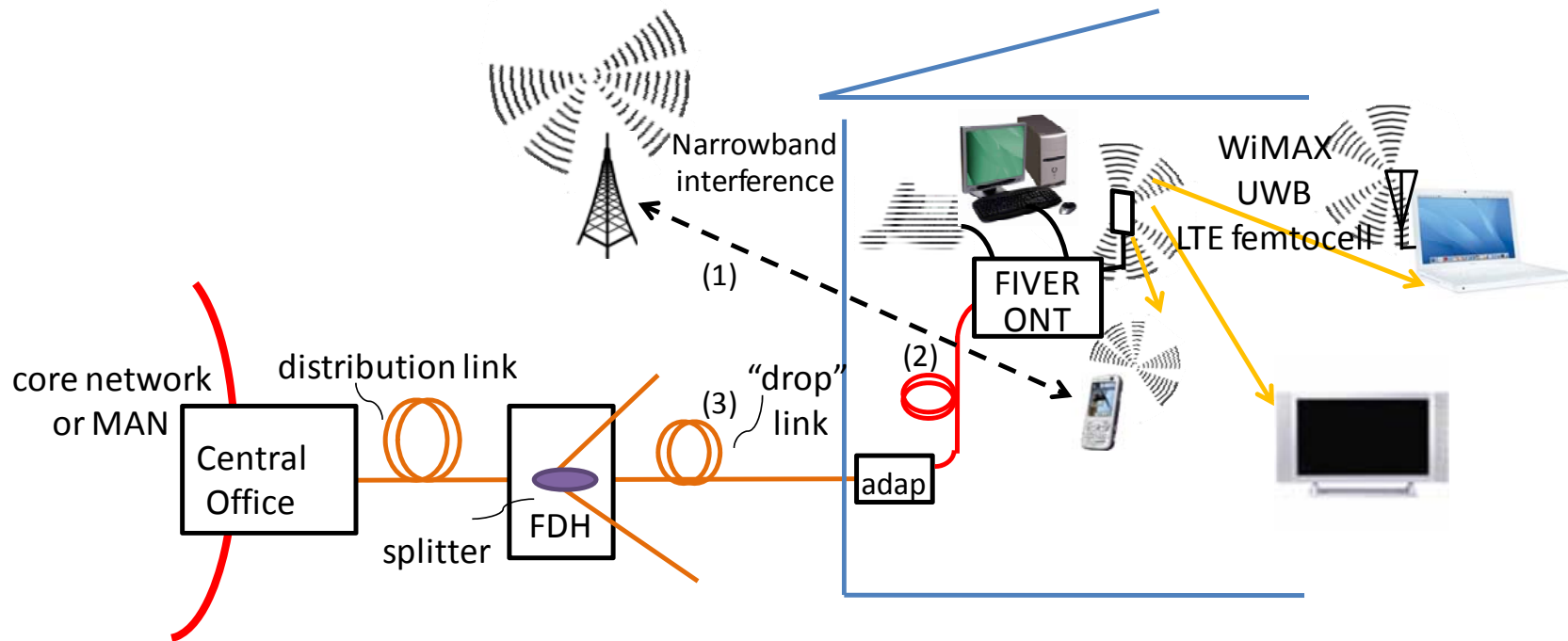

## Innovation: Centralised optical, radio-over-fibre and LTE femtocell network management

- Network management is integrated- OFDM-baseband GbE, UWB, WiMax and LTE
- Flexible, agile reconfiguration
- Supporting ONT configuration, fault and performance management (inc. DAA)
- Lead partners: PTIN

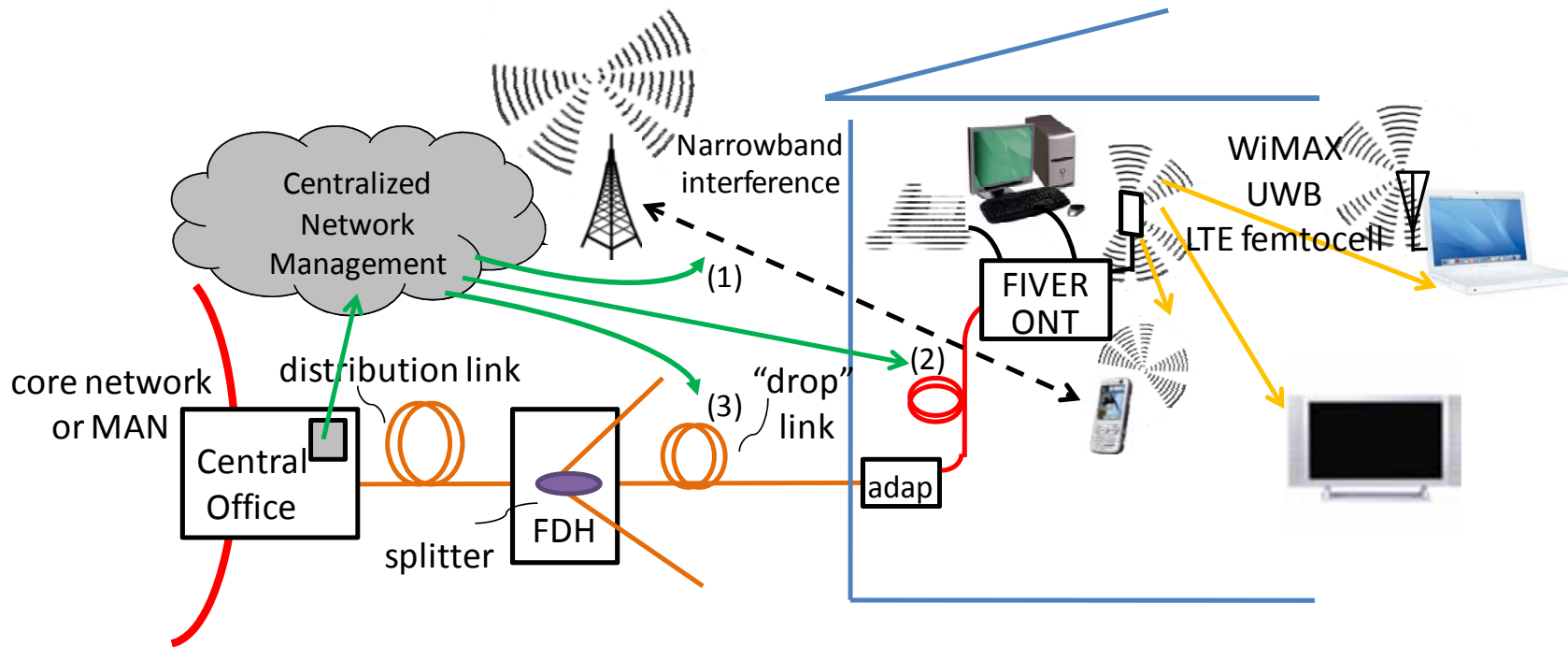

## Innovation: Optical media SSMF/UB-SMF, MMF/POF investigation

- By example, UWB is a short-range wireless with (m range)
- Fibre is required to distribute the signal
- **Ultra-bendable MMF or SSMF** possible implementations

Leading partner: CORNING



(February 2008) ClearCurve fibre, Corning [1]

(18 Sept. 2008) EZ-Bend fibre, OFS [2]

(19 Sept. 2008) BendBright-XS fibre, Draka Comm. [3]

[1] Ming-Jun Li, "Ultra-Low Bending Loss Single-Mode Fiber for FTTH", OFC 2008, PDP-11 February 2008

[2] BendBrightXS : Macrobending improved single mode fibre, Application Note, [www.drakafibre.com](http://www.drakafibre.com)

[3] Press Release:

[http://www.ofsoptics.com/press\\_room/view\\_press\\_release.php?txtID=247](http://www.ofsoptics.com/press_room/view_press_release.php?txtID=247)

## Innovation: 60 GHz radio

-Y3 will include UWB transmission (DS) in the 60 GHz radio

Lead partner: THALES

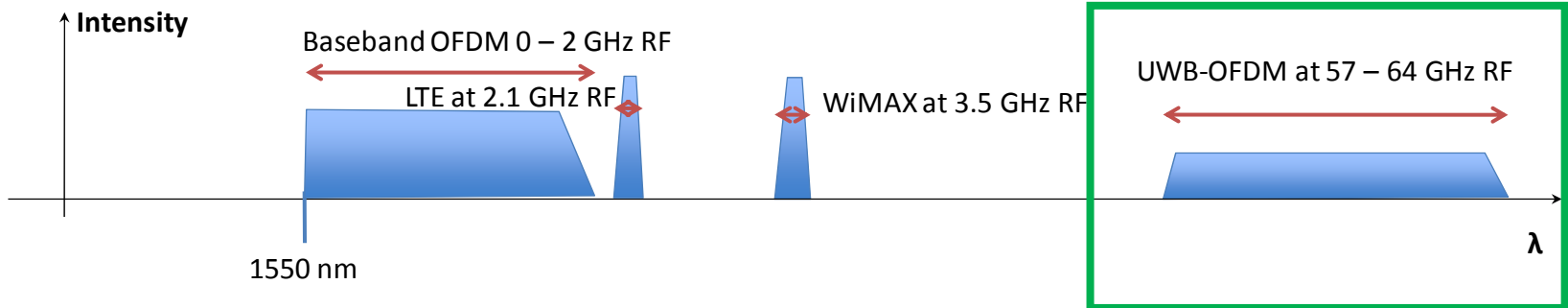
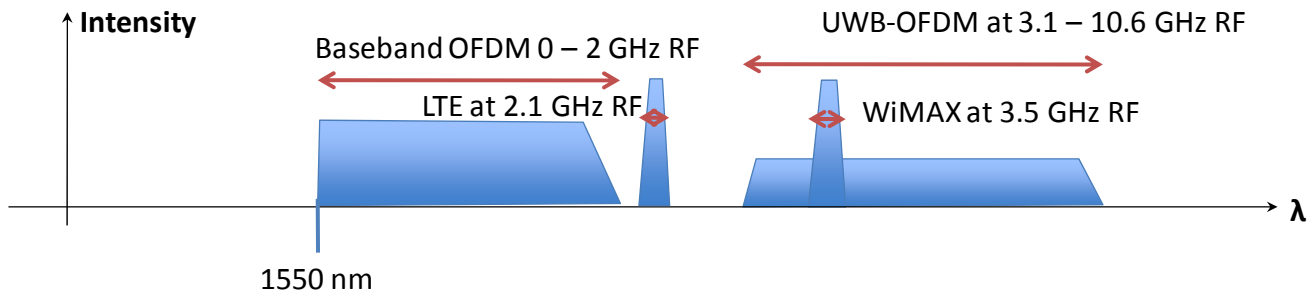

# Demonstration and assessment

## -Four demonstration stages:

1. Proof-of-concept: Basic FTTH operation including electro-optic compensation
2. Laboratory demonstrator: OFDM baseband+WiMAX/LTE+UWB
3. Lab. Demonstrator: OFDM baseband+WiMAX/LTE+ 60 GHz UWB
4. Open house show-room: demo environment of the 5-PLAY CONVERGED services (DAS)

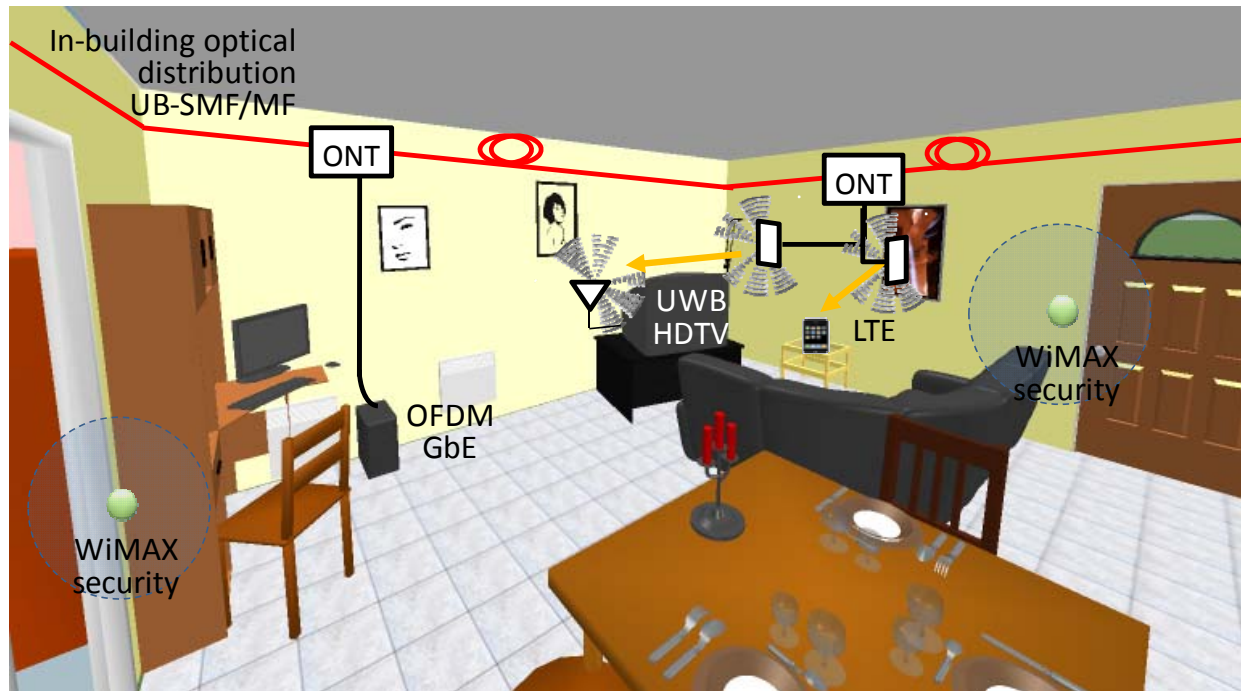

**Also..** Standardisation activities towards a 5-PLAY converged network

## Clustering with other FP7 projects

**-FIVER addresses an all-OFDM longitudinal optical/radio access to the user  
...this approach is complementary with other FP7 initiatives:**

- ACCORDANCE: Transversal OFDM(A) project (“all inside OFDM”)-
- MAINS: Sub-wavelength routing in METRO (METRO is the FIVER edge)
- OMEGA: Complementary activities at 60 GHz
- OASE: Collaboration in regulation/standardisation FSAN/ITU\_T
- ALPHA: Novel optical media performance evaluation possible
- FUTON: RoF performance  
(other possible...)

**FIVER**



Prof. Roberto Llorente

Email: [rllorent@ntc.upv.es](mailto:rllorent@ntc.upv.es)

---

[www.ict-fiver.eu](http://www.ict-fiver.eu)



Valencia Nanophotonics Technology Center