

Sharing **Physical Resources** – Mechanisms and Implementations for Wireless Networks

SAPHYRE

**Concertation Meeting
Brussels, 2010-01-27**



Project Coordinator: Hrjehor Mark
Technical Leader: Eduard Jorswieck
Dresden University of Technology, Communications Theory

- 7 trillion wireless devices will serve 7 billion people 24/7 by 2017 (WWRF vision)
- Small and scattered bands allocated for IMT-Advanced
- **Challenges:**
 - ❑ How to support competition between operators?
 - ❑ How to achieve cost- and energy-efficient deployment and operation?
- **SAPHYRE's solution:**
 - ❑ Spectrum sharing
 - ❑ Infrastructure sharing
 - ❑ New supporting radio technologies

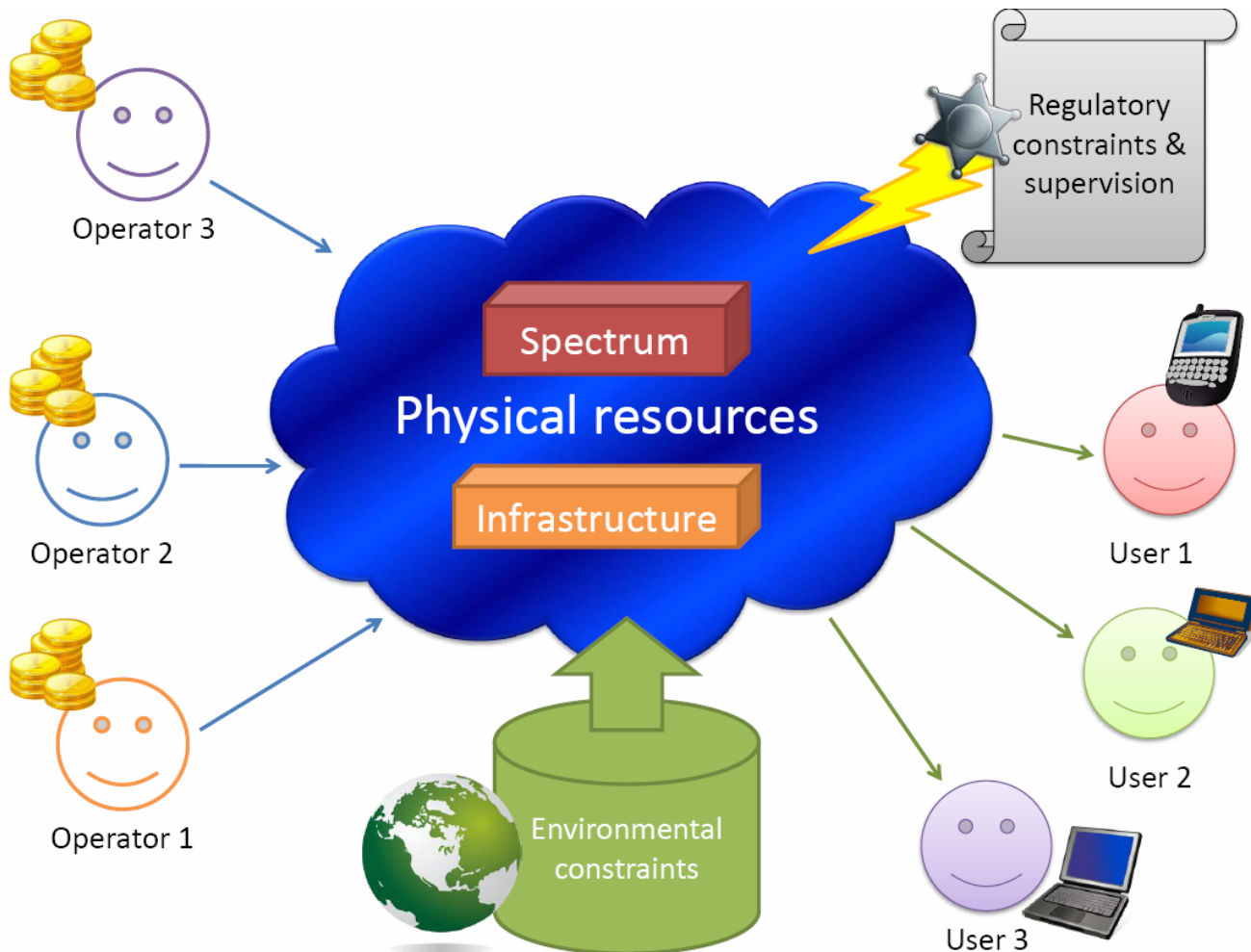

1. Flexible infrastructure sharing
2. New adaptive spectrum sharing models
3. High spectral efficiency

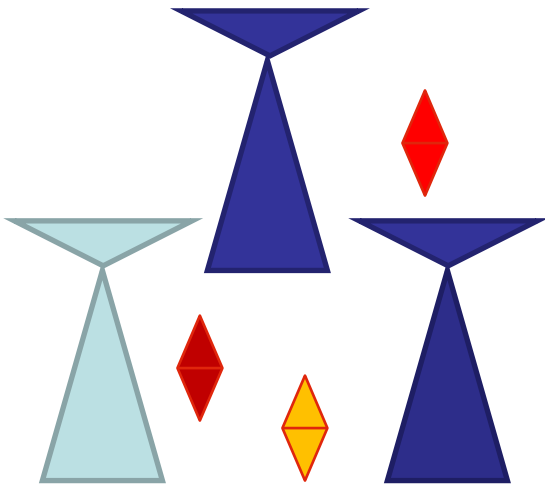

- Cross-layer and cross-disciplinary approach
- Efficient coordination and incentive based design
- Modern and novel physical layer techniques

- **Technische Universität Dresden**
- **Alcatel-Lucent Telecom Ltd.**
- **Consorzio Ferrara Ricerche**
- **České vysoké učení technické v Praze**
- **EURECOM**
- **Fraunhofer-Gesellschaft zur Förderung der angewandten
Forschung e.V. – Fraunhofer Institut für Telekommunikation**
- **Linköpings Universitet**
- **Telecom Italia S.p.A.**
- **Nederlandse Organisatie voor toegepast-natuurwetenschappelijk onderzoek**
- **Technische Universität Ilmenau**
- **Wrocławskie Centrum Badań EIT+ Sp. z o.o.**

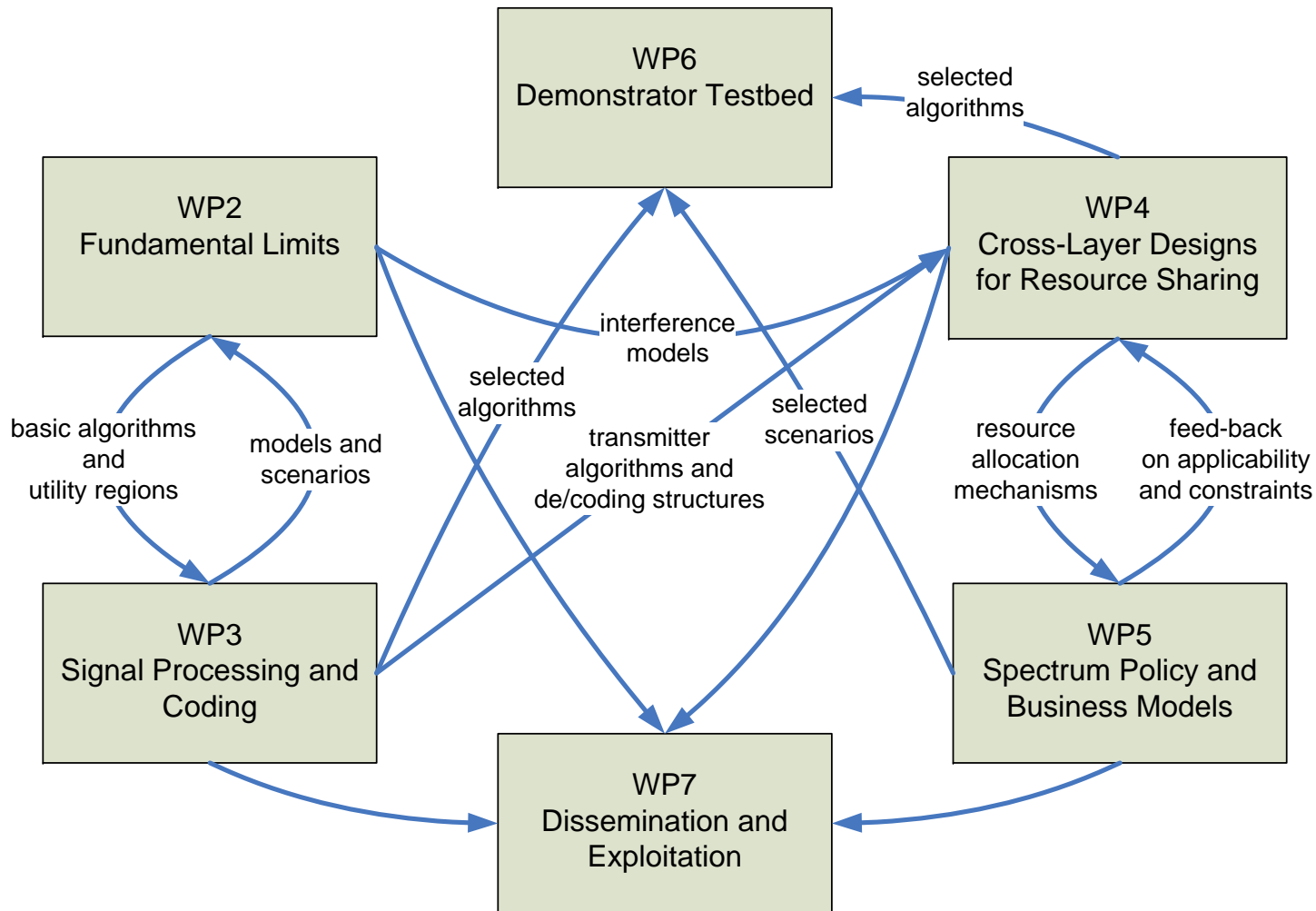

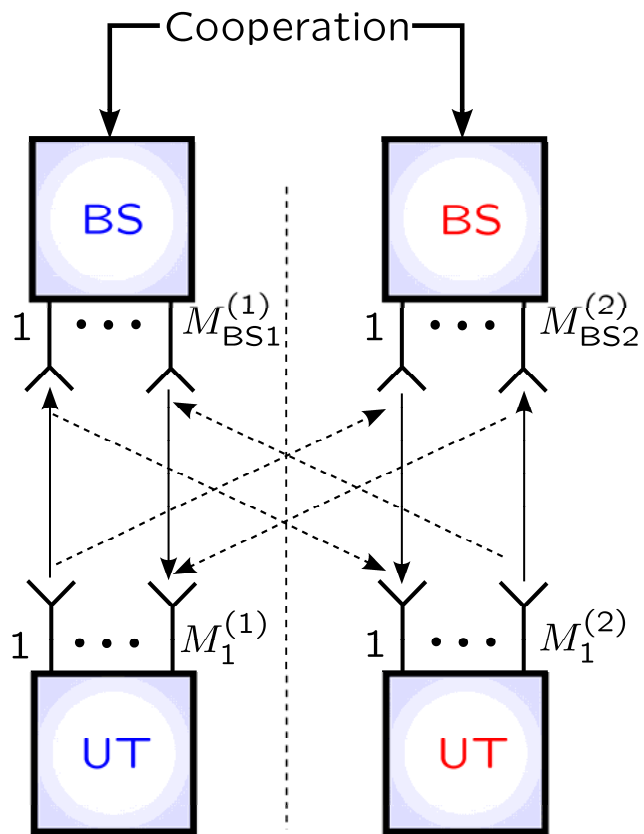

Basic spectrum sharing scenario

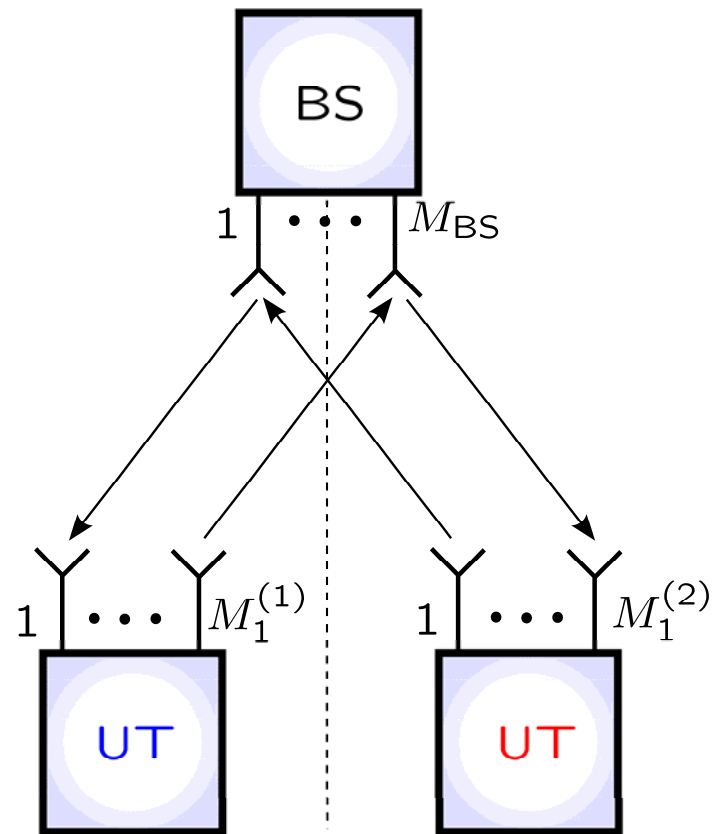

Basic infrastructure sharing scenario

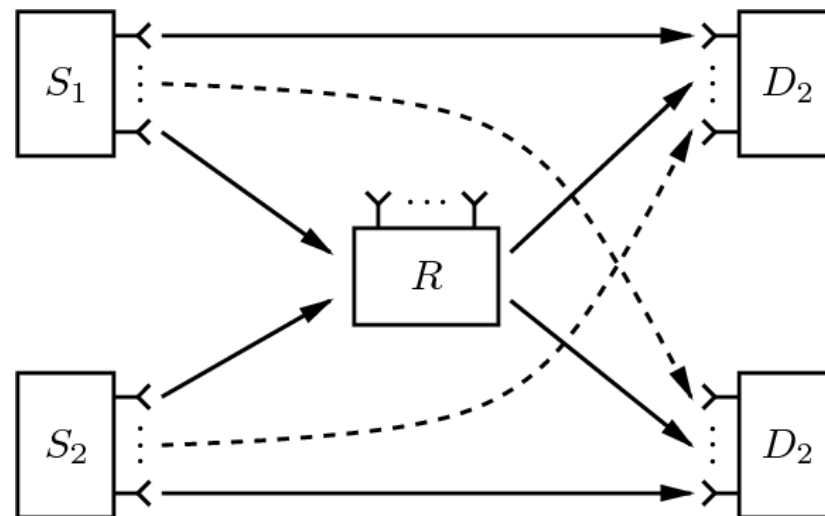
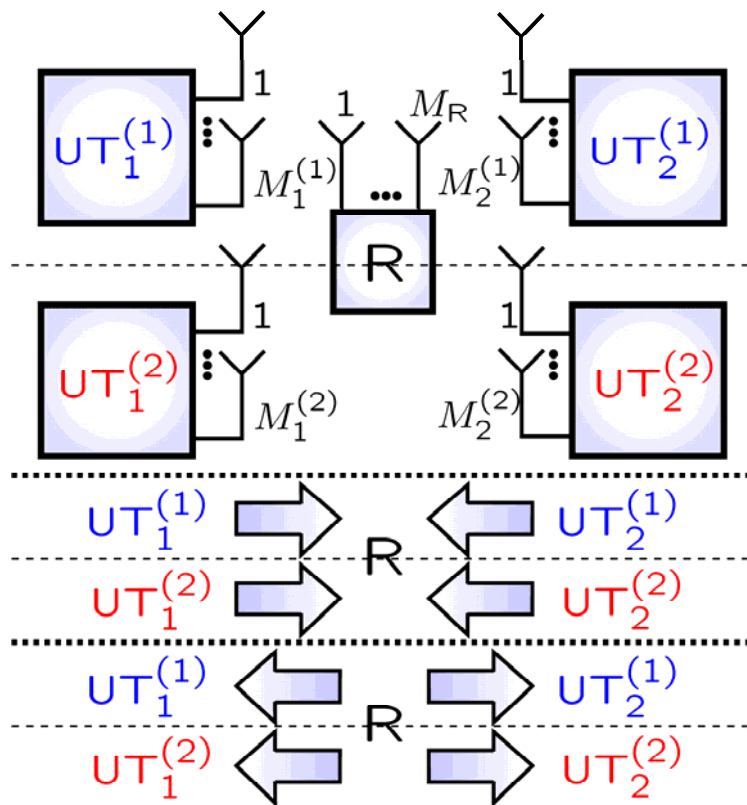

Combined spectrum and infrastructure sharing

Interference relay channel

- Project started in January 2010
- Homepage: www.saphyre.eu
- First dissemination activities:
 - CAMSAP 2009 (Keynote presentation)
 - CrownCom 2010 (General Co-Chair, TPC chair, panel)
 - European Wireless 2010 (special session)
 - ICT Mobile Summit 2010 (paper contributions)
 - Papers at all major IEEE conferences (com., sig.proc., inf.the., netw.)
 - First External Advisory Board meeting in preparation