



Enabling Innovation in the Internet Architecture through Flexible Flow-Processing Extensions

**Project overview for the FP7 Future Internet Cluster
Concertation meeting, 18th-20th October 2010**

Felipe Huici

CHANGE Technical Manager

NEC Laboratories Europe, NEC Europe Ltd.

{felipe.huici@neclab.eu}



- Start in October 2010, 3 years duration
- **Objective: Explore the capabilities of OpenFlow to enable more innovation in the Internet**
 - Develop an architecture for flow processing platforms within the network
 - On-path and off-path flow processing
 - Basis for flexible deployment of innovative services
 - Architecture validation through application implementation

Partner	Country
Eurescom (Prime Contractor)	Germany
NEC Europe Ltd. (Technical Coordinator)	UK
Deutsche Telekom	Germany
University College London	UK
Lancaster University	UK
Université catholique de Louvain	Belgium
Technische Universität Berlin	Germany
Universitatea Politehnica Bucuresti	Romania
Dreamlab Technologies	Switzerland
Nextworks	Italy
Universita` di Pisa	Italy

- **Size and scope of Internet make innovation difficult**
- **Core network technologies hard to change, leading to ossification**
- **Even minor changes done through point solutions**
 - These embed knowledge in the network, optimizing today's applications at the expense of tomorrow's

- **CHANGE wants to bring the concept of cloud into the network realm**
 - Using virtualized, multi-tenant, dynamic networks to provide Network-as-a-Service (NaaS)

- **In greater detail, industry players will benefit from the following:**
 - Promotion of OpenFlow-based technologies in Europe
 - Design innovative solutions for network systems based on flexible flow processing, paving the way for new market opportunities
 - Spin-off opportunities as well as increasing the patent portfolio in the area of flow processing
 - Enhancing the interoperability of CHANGE solutions by influencing standards related to the development of new products in the area of flow processing

- **CHANGE introduces the concept of a “flow processing platform” instantiated at critical points in the network**
 - Platform and interfaces are common but the processing performed is programmable
 - Programmability allows network to evolve and support rapidly-changing applications
 - Can be implemented using commodity hardware

- **Larger vision of project is an architecture**
 - Combines multiple communicating flow processing platforms to provide innovative end-to-end services
 - Traffic flows can be processed at varying degrees of granularity, and application-specific virtual network overlays can be dynamically constructed without impacting other network services or traffic
 - Architecture will be validated on three-site testbed by implementing a set of innovative applications over it

- **The platform consists of**
 - Hardware: Openflow (OF) switches and x86 servers called module hosts
 - Software: The platform's controller and the virtual machines called processing modules
- **Provides a Platform-as-a-Service (PaaS), e.g., in a data center**

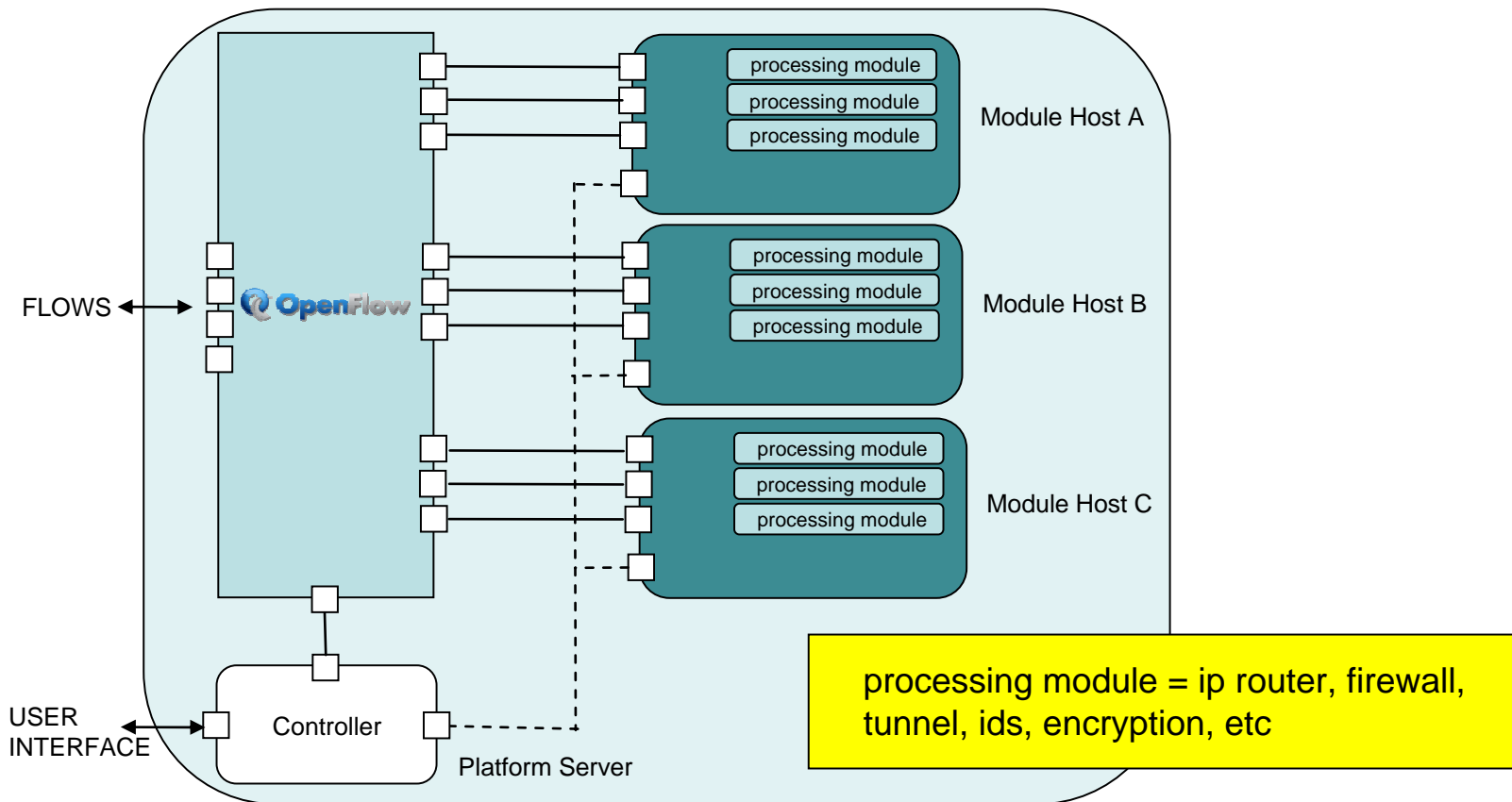

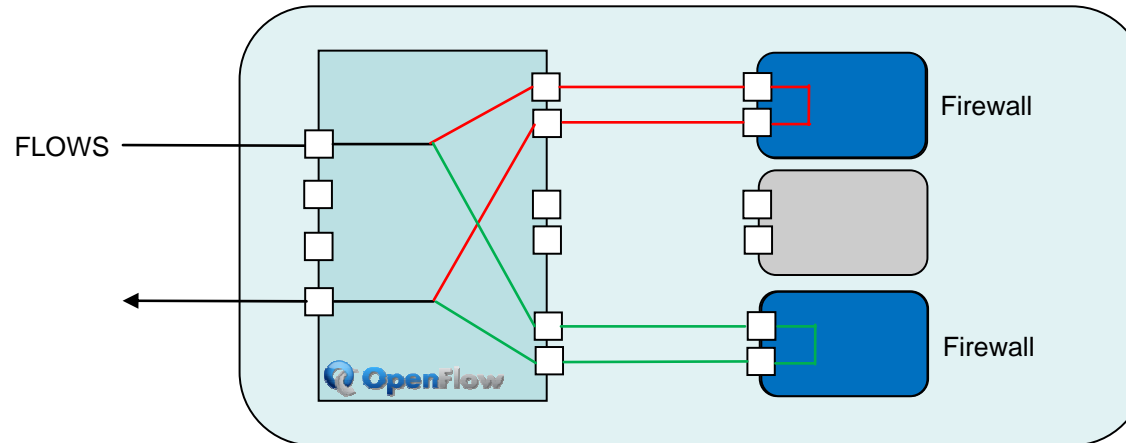

- The controller splits flows (for instance based on IP prefix) to two different module hosts
- Flows are processed in parallel
- Flows are then merged back together at OpenFlow switch

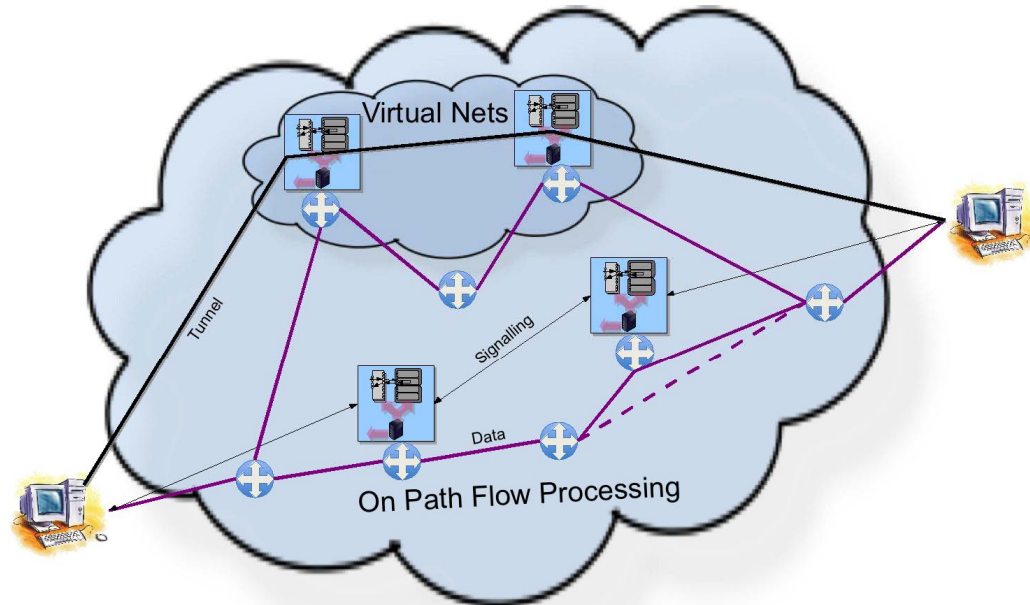

Virtual Nets

- Flows are classified and processed in one platform, then sent to another for further processing, and so on.
- These flow-level virtual networks give operators and application writers great flexibility in controlling how their traffic is forwarded and where it is processed.

On-Path Flow Processing

- Traffic using IP forwarding needs to be processed as a flow at certain points in networks (e.g., firewalls, traffic shapers)
- Platforms can accommodate this, but even more benefit comes when inter-platform signaling allows for end-to-end processing

In reality, these two concepts are likely to be used in combination

Website:

<http://www.change-project.eu>

Project co-ordinator:

Ádám Kapovits, Eurescom, kapovits@eurescom.eu

Technical manager:

Felipe Huici, NEC Europe, felipe.huici@neclab.eu