



# LABONFOIL: FP7 Integrated EU project



[www.labonfoil.eu](http://www.labonfoil.eu)

DTU Vet  
National Veterinary Institute



BIOTOOLS  
BIOTOOLS B&M LABS.S.A.



tataabiocenter



National Oceanography  
Centre, Southampton  
UNIVERSITY OF SOUTHAMPTON AND  
NATURAL ENVIRONMENT RESEARCH COUNCIL

micro resist  
technology

UNIVERSITY OF  
Southampton  
School of Electronics  
and Computer Science



GAIKER

ik4 research alliance

biosensia



Fraunhofer  
Institut  
Photonische  
Mikrosysteme



EVG®



DTU Nanotech  
Department of Micro- and Nanotechnology

GEMA MEDICAL S.L.

b+o

eusko fundazioa  
Fundación Vasca de Innovación  
e Investigación Sanitarias



Laboratory Skin Patches and SmartCards based on foils and compatible with a smartphone

Jesus M. Ruano-López  
Ikerlan-IK4

To promote collaboration between projects by developing new ideas or clusters

- *Breaking concepts*
- *Combining fields*
- *Laying down analogies*
- *Defining paradoxes*
- *Using unconscious state*



*“Ideas about scientific imagination”, Ed. Jorge Wagensberg*

- Objectives of the project
- Development and achievements
  - Labcard
  - Integration
  - Skinpatch
  - Fabrication tool
- Limitations, future challenges and cluster collaborations in 2 or max 3 slides.

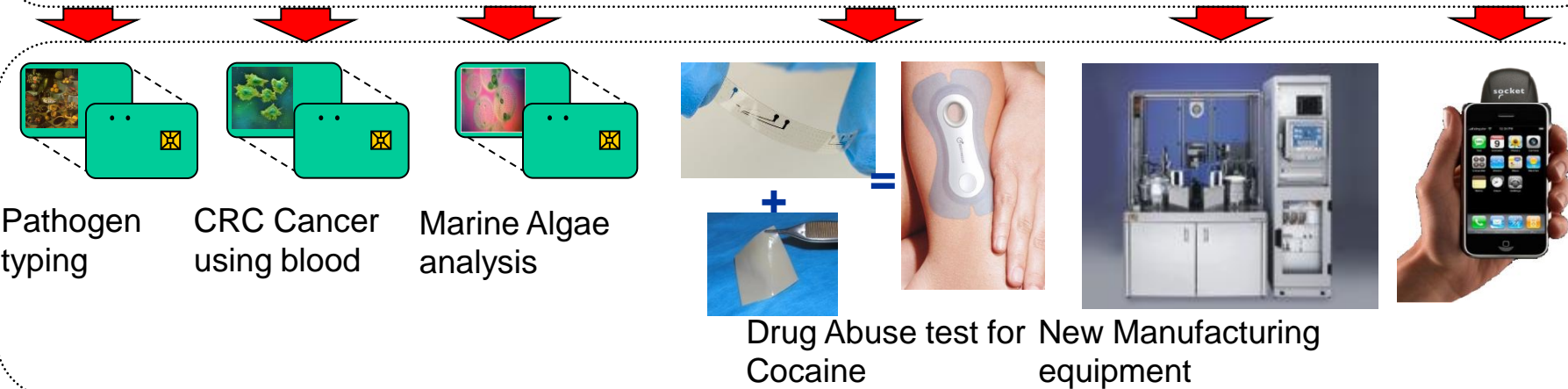
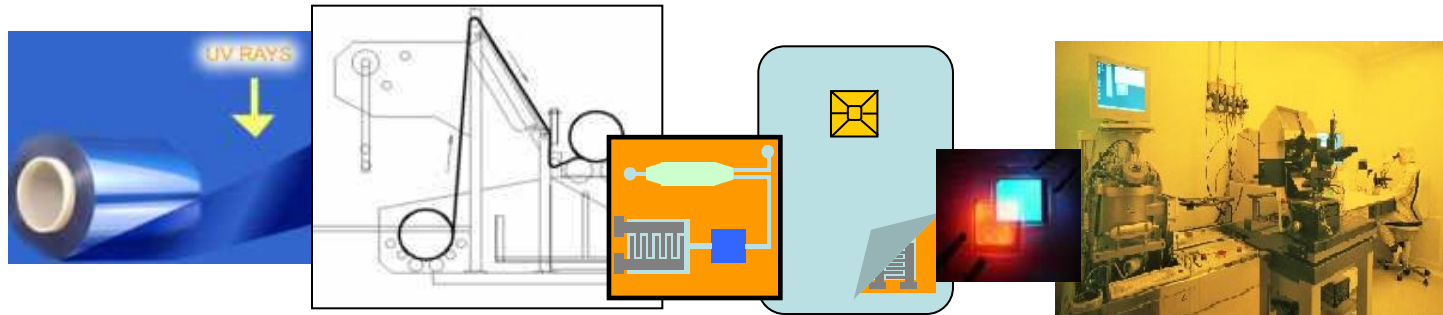

- Lab on Foil as next LOC generation: Labcard and Skin patch.
- Four applications: Cancer, Food, Environment, drug abuse.
- Cheap manufacturing on dry film resist foils.
- Smartphone as an interface device: SmartBioPhone.
- Vision: the seed of a new industry.

# Labcard achievements

- Definition of needs and specifications
  - Developed single reactions on tube
  - From SU8 to COC reactors
  - 4 Reactor Units delivered to Bio partners
  - Developed single reactions on chip
- Validation issues**

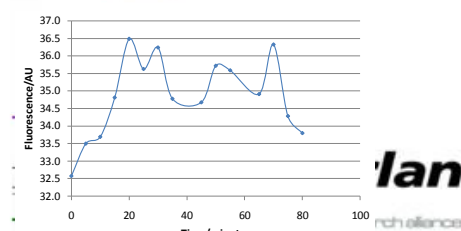
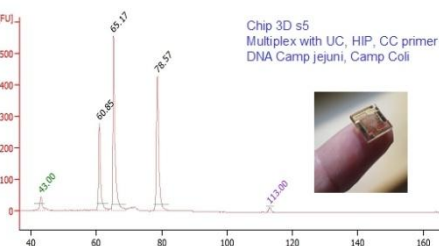
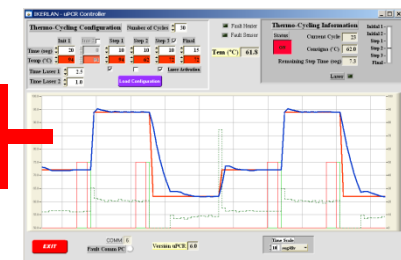
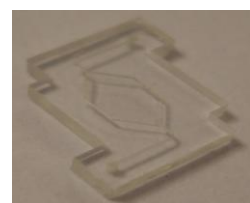
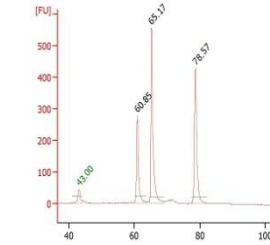
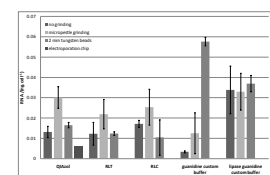
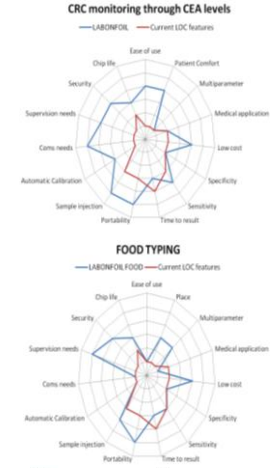
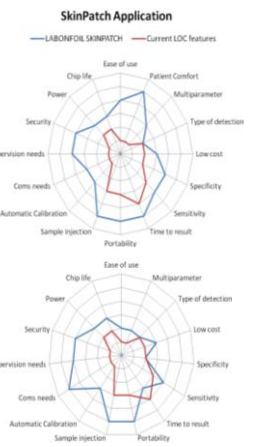
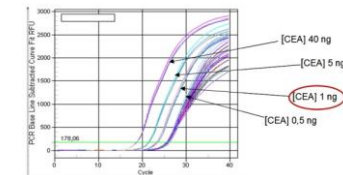

## • Labcard integration

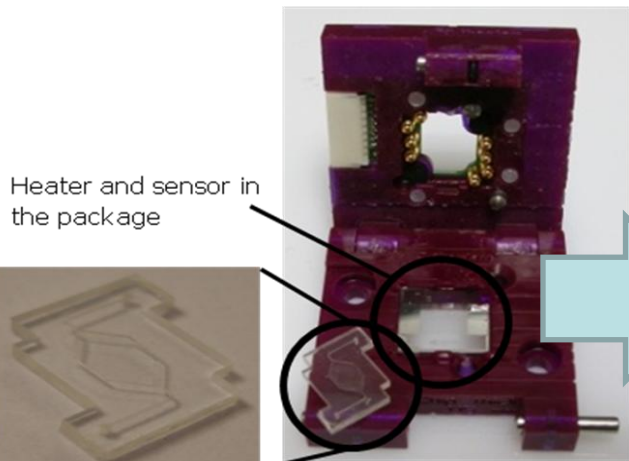

Heater and sensor in the package

Passive COC LoC chip (top view)

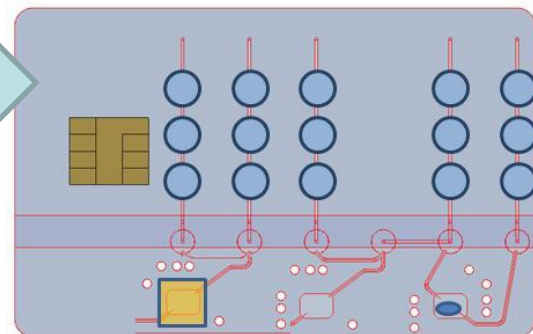
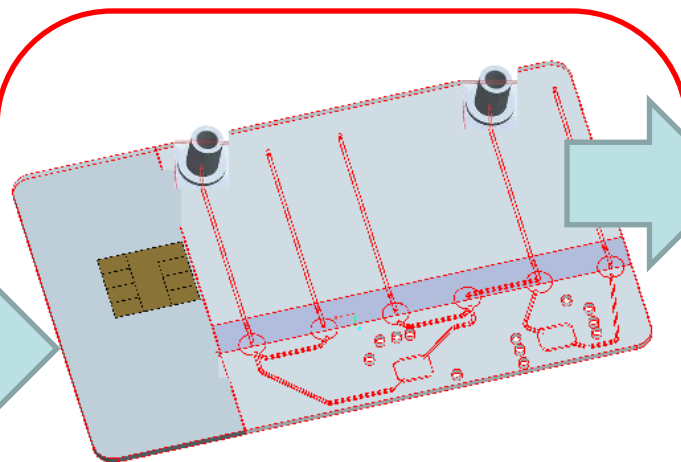

## • Reader integration

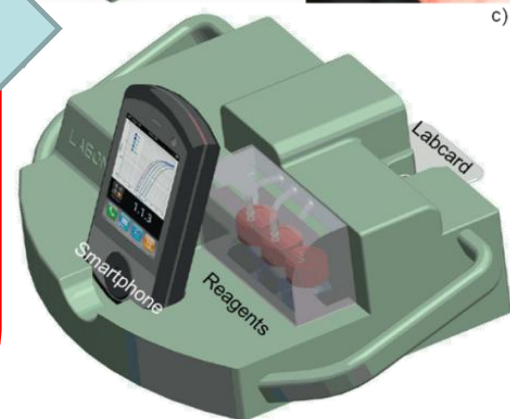
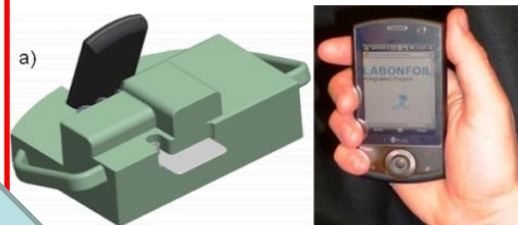
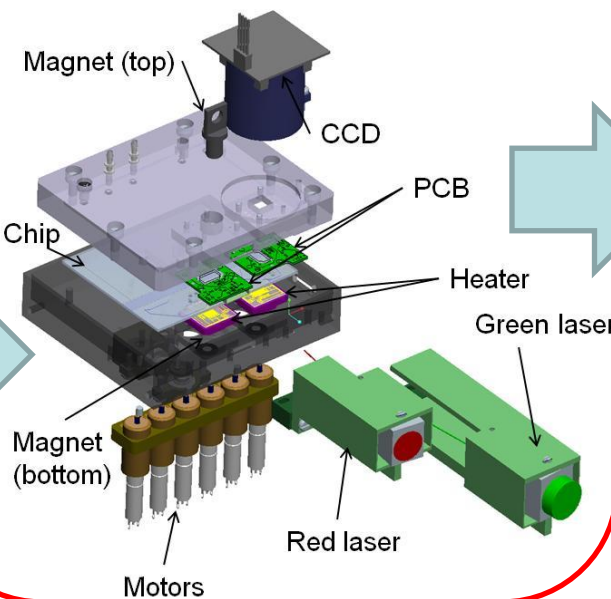

- Definition and design



- Developed Skin patch and reader

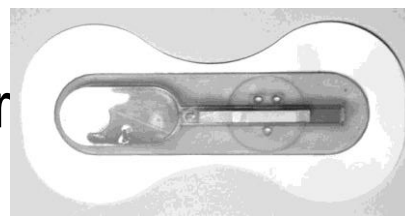

- Developed competitive reactions on skinpatch with optical detection

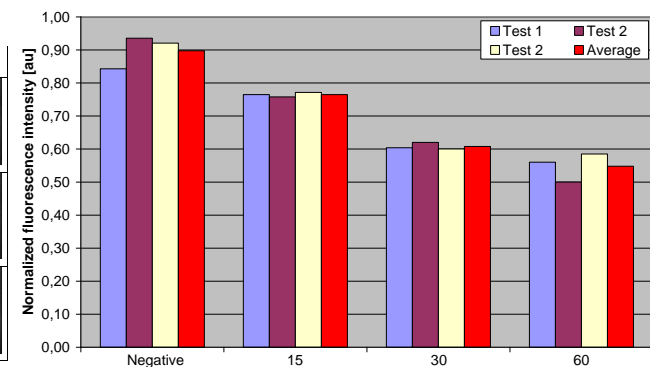
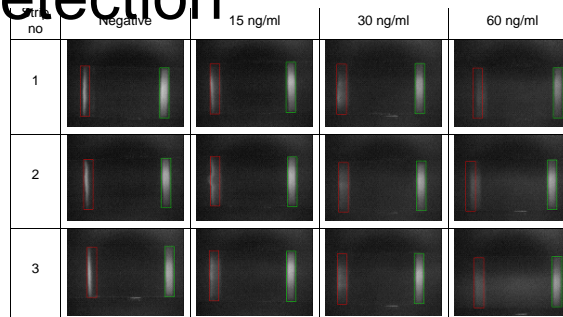

- Developed OLEDs with integrated filters

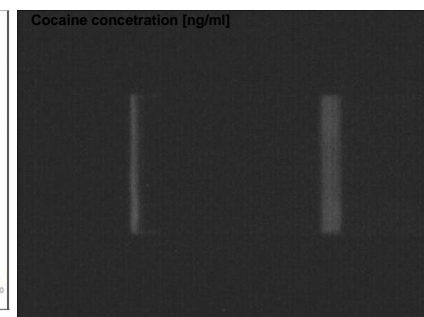
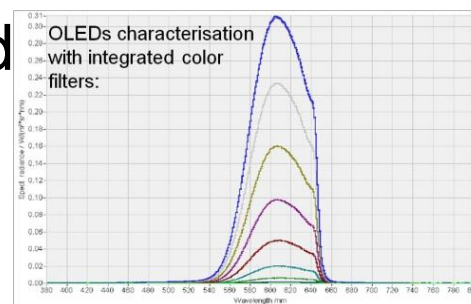

- Sample collection experiments

**Validation issues**

- Analysis of processes involved

- Single tests

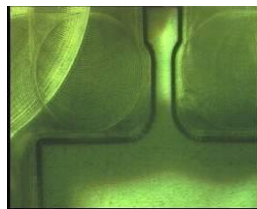
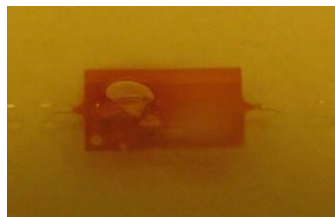

- Colaboration with a German project



- Definition of final list of processes

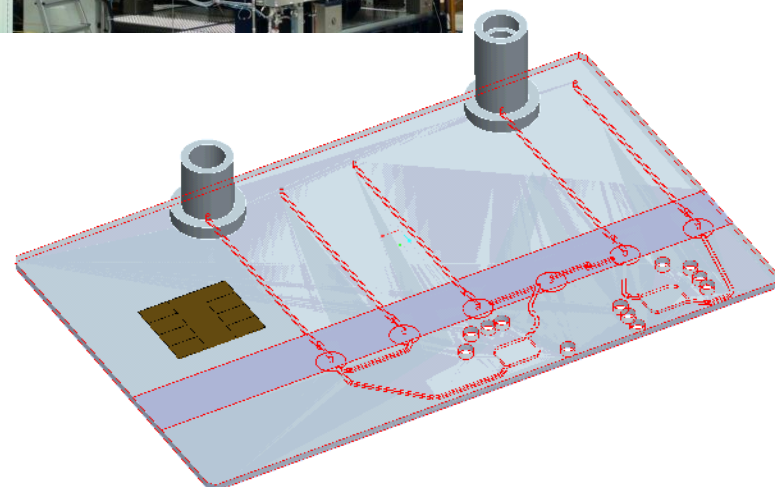
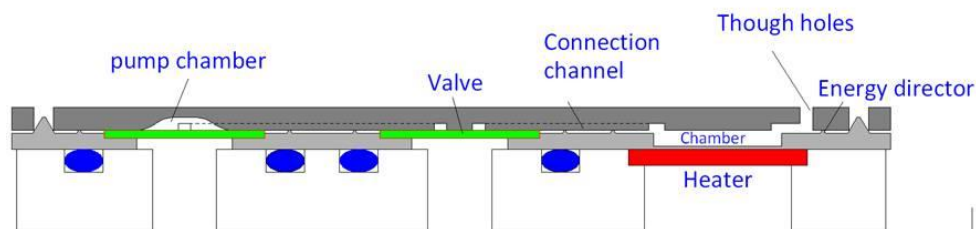

- Fabrication of the tool

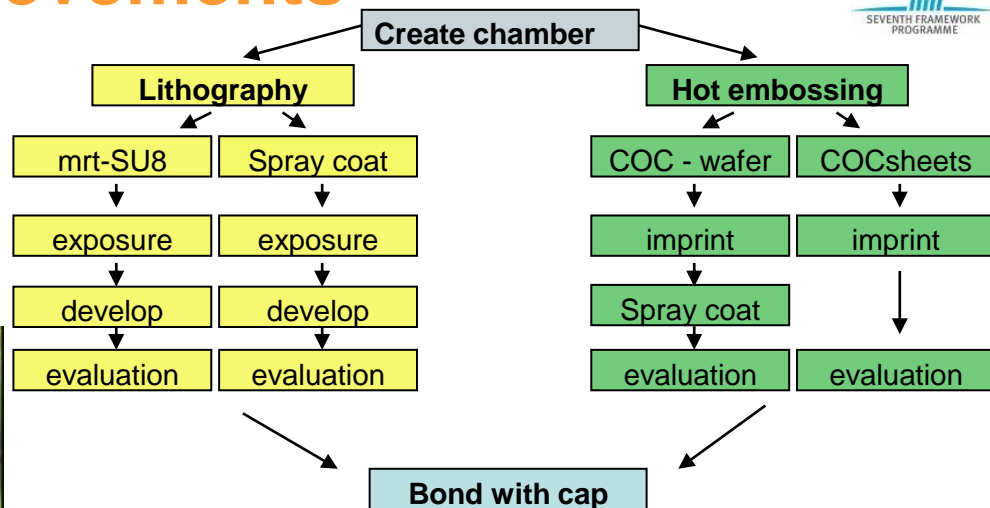

# Solutions

- Web based meetings
- Sharepoint as a central database
- Good diffusion obtain through a comic

# Limitations

- SU-8 auto fluorescence
- Low temperature bonding
- Algae more difficulty due to rock nature
- Limitations in terms of collaboration among EU projects
- No centralized activities. Join of small projects
- Difficulty to connect our research with big diagnostic companies

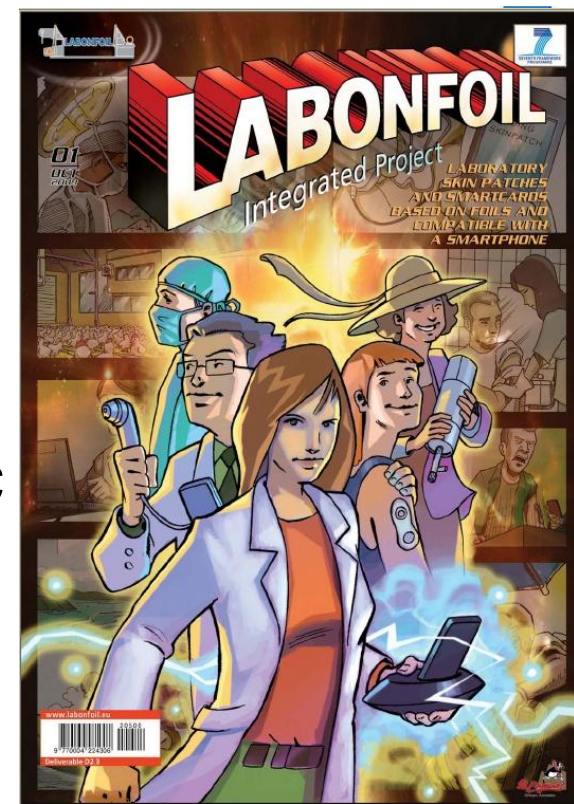

5 10 15 20 25 30

years

Business creation

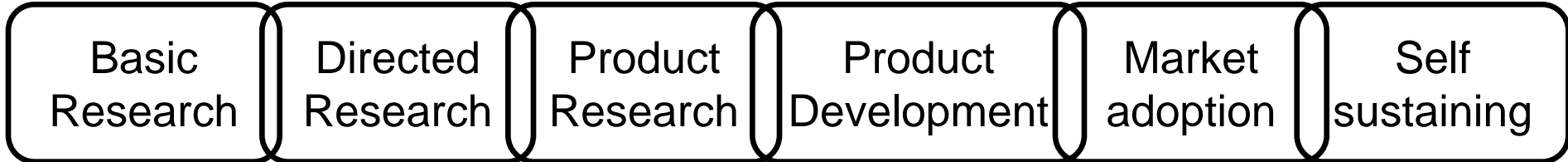

- Design Approach
- Core Operations
- Core functions
- Design and Test
- Validation



- Demonstration
- Core components
- Integrated system operation
- Trials for internal evaluation
- Regulatory requirements
- Specification Document
- Customer map
- Strategic partners

LoF User club

- Be periodically informed about the progress of the project and achieved goals, through the participation in annual workshops
- Influence on the definition of the scenarios and requirements of the four foreseen prototypes
- Possibility to participate in the primary testing/validation of the developed prototypes
- “Privilege position” to discuss with LABONFOIL consortium different



Food



Cancer

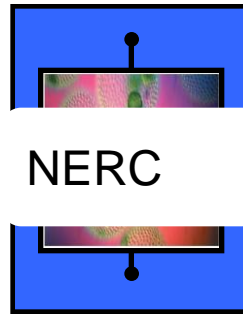

Environment



BS



GM



EVG



IK



WUT

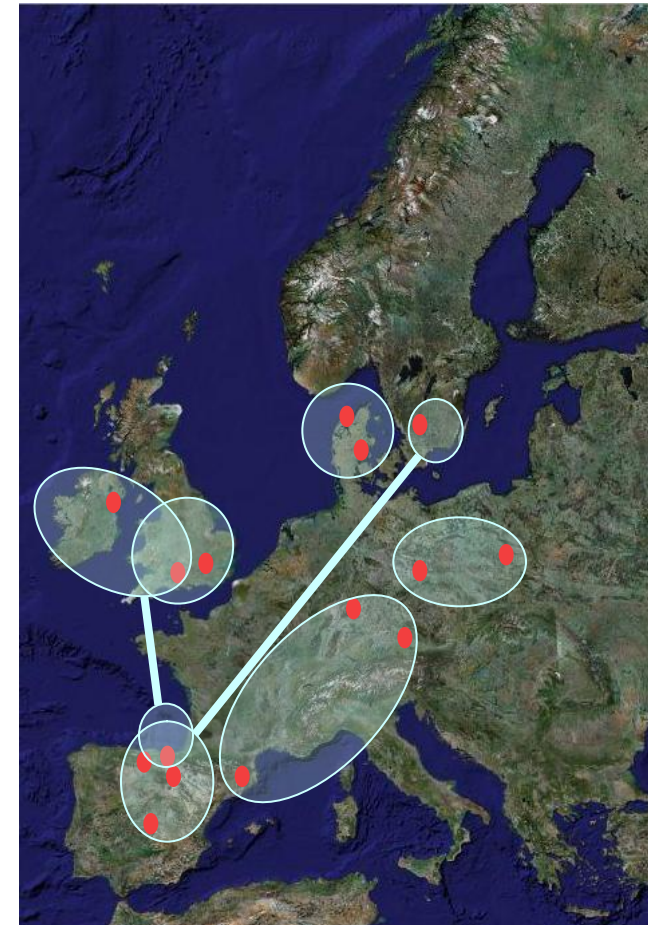

- We have to avoid too many consortium meetings with all partners
- Locations that allow everyone to get one flight
- Components should be related to geographical areas

# Conclusions

WhichBudget.com

vueling.com

RYANAIR.COM

VirginExpress.com 

airberlin.com

easyJet.com  
Come on, let's fly!



DELL

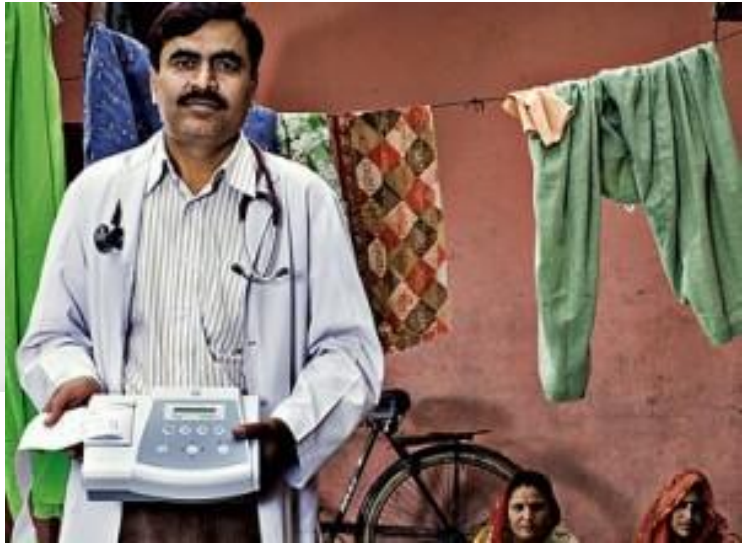

## LABONFOIL

Integrated Project

presents:

**3rd Annual workshop  
“Lab-on-a-Chip  
exploitation in emerging  
and third developing  
countries”**

**Madrid, 30th April 2010**

**Contact Noelia Pérez**

**Bioteools B&M Labs, S.A**

**Tel.: +34-91-710-00-74**

**[noelia@bioteools.eu](mailto:noelia@bioteools.eu)**



## SESSION I

8:45 Registration

9.00 Introduction and presentation

9.15 Sebastien Fournier, Chief Technology Officer, Fio Corporation, Canada

9.45 Mikel Alvarez Yeregi, General Director, Mondragon Health, Spain

10.15 Cees van Berkel, Principal Scientist, Philips Research UK, UK

10.45 Break

11.45 Markku Käsäkoski, Senior Research Scientist, BiomicroSystems, VTT, Finland

12.15 Sonia Rodriguez, R&D Coordinator, Bioteools B&M Labs, Spain

### Lunch Break

## SESSION II

14.00 CIC microgune, Estefania Abad, Spain

14.30 Marco Aurelio Krieger , Scientific Director, IBMP, Paraná, Brazil

15.00 Break

15.15 Frédéric Breussin, Project Manager, Yole Développement, France

15.45 Sara Delaney, Research Associate, LIDC/UKCDS, UK

16.15 Debate and Round table

17.15 End of the meeting.

### Registration fee

45€