

D2.1

Report on the initial DISCUS End to End Architecture

Dissemination Level: PU

- **Dissemination level:**

- **PU = Public,**

- RE = Restricted to a group specified by the consortium (including the Commission Services),

- PP = Restricted to other programme participants (including the Commission Services),

- CO = Confidential, only for members of the consortium (including the Commission Services)

Abstract:

The major objective of DISCUS is to produce an end to end design (access, metro and core network) for a future network architecture that can deliver ubiquitous very high speed broadband services to all users of the network. The architectural design must meet this objective, remain economically viable and reduce energy consumption by at least 95% as they scale to deliver bandwidth capability at least three orders of magnitude greater than today's networks.

This deliverable provides a description of the initial ideas and options for an end to end architectural solution that could deliver this objective and meet these economic and energy consumption challenges. It is an initial position and will change and evolve as learning within the project develops. However there are a number of basic principles within the architectural options described that will remain as key elements of the design as the details evolve and develop over the project duration, these are:

- A long reach access solution to bypass local exchanges and eliminate separate metro transmission networks.
- A flat optical layer in the core network to interconnect a relatively small set of network nodes.
- Minimisation of electronic processing as far as possible by large scale node consolidation and elimination of the majority of local exchange / central office sites
- Sharing network infrastructure and resources over as many customers as possible.

COPYRIGHT

© Copyright by the DISCUS Consortium.

The DISCUS Consortium consists of:

Participant Number	Participant organization name	Participant org. short name	Country
Coordinator			
1	Trinity College Dublin	TCD	Ireland
Other Beneficiaries			
2	Alcatel-Lucent Deutschland AG	ALUD	Germany
3	Nokia Siemens Networks GMBH & CO. KG	NSN	Germany
4	Telefonica Investigacion Y Desarrollo SA	TID	Spain
5	Telecom Italia S.p.A	TI	Italy
6	Aston Universtity	ASTON	United Kingdom
7	Interuniversitair Micro-Electronica Centrum VZW	IMEC	Belgium
8	III V Lab GIE	III-V	France
9	University College Cork, National University of Ireland, Cork	Tyndall & UCC	Ireland
10	Polatis Ltd	POLATIS	United Kingdom
11	atesio GMBH	ATESIO	Germany
12	Kungliga Tekniska Hoegskolan	KTH	Sweden

This document may not be copied, reproduced, or modified in whole or in part for any purpose without written permission from the DISCUS Consortium. In addition to such written permission to copy, reproduce, or modify this document in whole or part, an acknowledgement of the authors of the document and all applicable portions of the copyright notice must be clearly referenced.

All rights reserved.

TABLE OF CONTENTS

1	INTRODUCTION	6
1.1	THE PHILOSOPHY OF THE DISCUS ARCHITECTURE	7
1.2	THE END TO END DISCUS ARCHITECTURE	9
1.3	THE OPTICAL ISLAND CONCEPT	10
2	LR-PON OPTICAL ACCESS NETWORK	12
2.1	INITIAL DISCUS ARCHITECTURE - SINGLE FIBRE ODN, TWO FIBRE BACKHAUL	12
2.2	ALTERNATIVE LR-PON ARCHITECTURES	15
2.2.1	<i>LR-PON architecture - two fibre working in the ODN and backhaul....</i>	<i>15</i>
2.2.2	<i>LR-PON architecture - single fibre in ODN and backhaul.....</i>	<i>16</i>
2.2.3	<i>LR-PON architecture - Single fibre vs. two fibre comparison.....</i>	<i>17</i>
2.3	40GB/S DOWNSTREAM FOR LR-PON	20
2.3.1	<i>40Gb/s down stream transmission</i>	<i>20</i>
2.3.2	<i>40Gb/s down stream transmission using ONU with SOA</i>	<i>21</i>
2.4	LR-PON RESILIENCE OPTIONS	23
2.4.1	<i>Basic dual parenting protection for all users</i>	<i>23</i>
2.4.2	<i>Improved protection via two paths through the ODN</i>	<i>24</i>
2.4.3	<i>Full protection via two separate LR-PON connections.....</i>	<i>25</i>
2.4.4	<i>Summary of protection options for LR -PON:.....</i>	<i>26</i>
2.5	LR-PON OPTICAL POWER BUDGETS.....	27
2.6	RURAL OR SPARSE POPULATION SOLUTIONS.....	30
2.6.1	<i>Rural areas LR-PON design option - increase ODN length.....</i>	<i>30</i>
2.6.2	<i>Rural areas LR-PON design option - Multiple ODNSections</i>	<i>31</i>
2.7	AMPLIFIER NODE DESIGN ISSUES AND OPTIONS	34
2.7.1	<i>Amplifier node for single fibre ODN and two fibre backhaul.....</i>	<i>34</i>
2.7.2	<i>Amplifier node for single fibre ODN and single fibre backhaul.....</i>	<i>35</i>
2.7.3	<i>Amplifier node for two fibre ODN and two fibre backhaul.....</i>	<i>36</i>
2.7.4	<i>Amplifier node example using WDM components</i>	<i>37</i>
2.7.5	<i>Additional optical amplifier design considerations.....</i>	<i>38</i>
2.8	CANDIDATE MODULATION TECHNIQUES FOR CORE BANDWIDTH OVER LR-PON INFRASTRUCTURE.....	39
2.8.1	<i>Options for core wavelength Transmission over LR-PON - DP-QPSK....</i>	<i>39</i>
2.8.2	<i>Options for core wavelength Transmission over LR-PON - CO-OFDM..</i>	<i>39</i>
2.8.3	<i>Options for core wavelength Transmission over LR-PON - - "Flex-grid" & Nyquist-WDM</i>	<i>41</i>
2.8.4	<i>Challenges for Core transmission over LR-PON</i>	<i>42</i>
2.9	OLT CONFIGURATION OPTIONS.....	43
2.10	BESPOKE NETWORKS SOLUTION OVER LR-PON INFRASTRUCTURE	47
2.10.1	<i>Bespoke WDM LR-PON network configuration.....</i>	<i>48</i>
2.10.2	<i>Bespoke network configurations using spare fibre in LR-PON cable.</i>	<i>50</i>
3	THE METRO-NODE CORE DESIGN	51
3.1	THE OPTICAL SWITCH LAYER	52
3.1.1	<i>Two sided Clos switch using optical beam steering matrices.....</i>	<i>54</i>
3.1.2	<i>Single sided Clos switch using optical beam steering matrices</i>	<i>56</i>
3.1.3	<i>Partitioned Single sided Clos switch using optical beam steering matrices.....</i>	<i>58</i>
3.1.4	<i>Growing the optical switch layer</i>	<i>61</i>
3.2	ALTERNATIVE METRO NODE STRUCTURE	63

3.3	ELECTRONIC SWITCH LAYERS INTERCONNECT	65
3.3.1	<i>Layer 2 switch interfaces interconnection</i>	65
3.3.2	<i>Layer 3 router interfaces</i>	66
3.3.3	<i>Implementation of Quality of service</i>	67
3.3.4	<i>Integrated L2 and L3 switching and control</i>	67
4	THE FLAT OPTICAL CORE NETWORK	70
4.1	COMPLIANCE WITH NGN ARCHITECTURAL STANDARDS	70
4.2	CORE ARCHITECTURE DRIVERS	71
4.3	PHOTONIC LAYER AND TRANSMISSION TECHNOLOGIES	73
4.4	PACKET TRANSPORT LAYER	75
5	END TO END DESIGN CONSIDERATIONS	80
6	SUMMARY/CONCLUSIONS	81
	REFERENCES	84
	APPENDICES	85
	APPENDIX (A) THE L2 SWITCH LAYER FUNCTIONALITY	85
	<i>Layer 2 switch interconnect to other layers</i>	87
	APPENDIX (B) THE L3 ROUTING FUNCTIONALITIES	90
	APPENDIX (C) NETWORK SERVICES REQUIREMENTS	91
	ABBREVIATIONS	94

1 Introduction

The overall objective of the DISCUS project is to design a network architecture that can deliver ubiquitous high speed broadband access to all users independent of their geographical location. Furthermore, the topology will target economic viability as user bandwidths grow by at least three orders of magnitude while improved energy efficiency will ensure significant power savings over current network configurations (of order 95%). In addition, DISCUS aims to deliver core network bandwidth capability to the access edge so that direct connection to the core network is available from any access terminal fitted with the appropriate technology

The DISCUS architecture must also be able to evolve from today's networks and the ability to evolve gracefully will be an important consideration of the design. It is also important that the DISCUS architecture does not itself become a legacy network and will therefore need to adopt new technologies and systems as they emerge in the future.

Efficient high speed broadband communications networks are essential for thriving communities in the modern world. Ideally, all users and all communities should have equal access to high speed broadband so that there is no division of service availability due to customer location. However, many countries still exploit old copper transmission technology and are now in danger of creating a digital divide between those with good copper access close to the operator's electronic infrastructure and those located in more remote areas connected via much longer copper lines. There are also problems with wireless access solutions that are used to deliver broadband. In particular, wireless base stations must be located so they can capture a sufficiently large number of customers to make their deployment economically feasible. This inevitably leads to more remote areas getting less effective coverage than more densely populated regions with reduced bandwidth capability and quality of service as a result. Nevertheless, even in populous areas with good coverage, bandwidth availability can be variable depending how many users are actually within a particular coverage area at any one time and the spectrum available for that area. Ultimately wireless base stations for broadband services may evolve to femto cells where they are effectively part of the ONT of the FTTP solution. In this case they become the tetherless edge of the network in the same way as Wi-Fi is used today.

Ultimately, the only technology that can deliver ubiquitous high speed broadband is Fibre to the Premises (FTTP), in this report we use the term FTTP, rather than FTTH (fibre to the home) to include all fibre terminations including business premises, radio base stations etc. not just residential customers.

The main problem with FTTP is that of financial viability. Firstly, there is the obvious problem of paying for the cost of the network infrastructure and its deployment, but there is a further financial problem arising from the sheer

capability of FTTP networks to grow user bandwidth compared to copper and wireless technologies. If FTTP is used to provide the future high speed broadband services that customers require then the bandwidth entering the metro and core networks will have to grow in proportion therefore the network capacity will need to scale accordingly. Unfortunately, revenue will not scale proportionally and the returns growth will not cover the cost of the bandwidth provision required. Furthermore, a reduction in the price of electronics will not be sufficient to reduce telecommunications equipment prices fast enough to ensure economic sustainability **Error! Reference source not found.** while another issue is the ever increasing power consumption of the electronic equipment required to service the projected bandwidth growth.

1.1 The philosophy of the DISCUS architecture

If it is accepted that ubiquitous high speed broadband is a requirement of a future network and it is also accepted that services will evolve to exploit the capability of FTTP and therefore user bandwidth could grow by at least two to three orders of magnitude, then there is a logical flow that inevitably leads to an architecture that must be similar to the DISCUS architectural proposal. That is, some version of the DISCUS architecture is inevitable and unavoidable if communications is to remain at the heart of a modern society. This logical flow is illustrated in **Error! Reference source not found.** and described below:

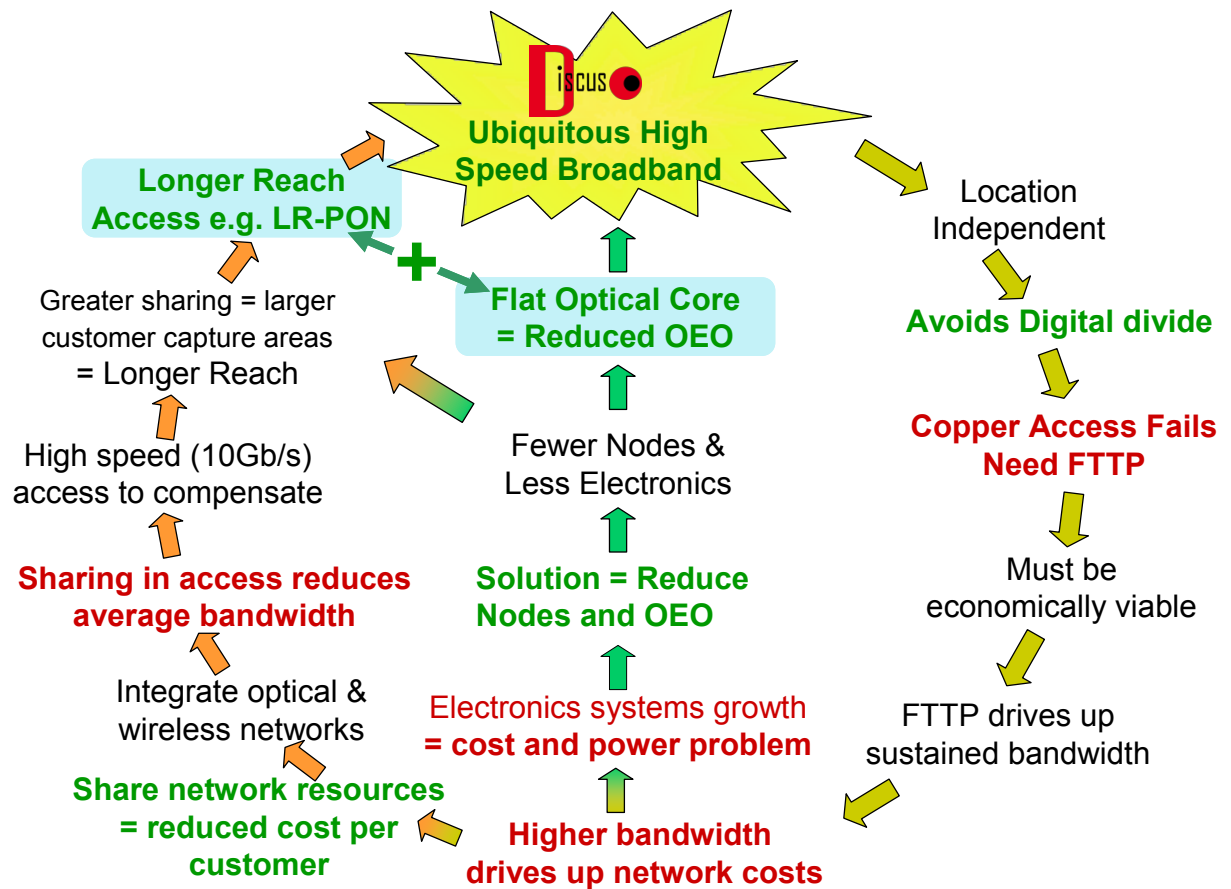

Figure 1 The DISCUS architecture - a logical necessity

- We accept that ubiquitous broadband is a major requirement of a future broadband network and is a driving objective.
- Therefore all network services should be available and have equivalent capability at any location of an optical network termination point. This is one of the stated principles for the DISCUS architecture.
- Technologies that are location dependent or local environment dependent such as copper access technology cannot deliver this ubiquitous capability.
- FTTP becomes the inevitable solution for the access network if we want ubiquitous high speed broadband. It is the only technology that can provide equal service capability everywhere.
- But if FTTP is deployed as the universal future solution the network must still remain economically viable.
- It is also apparent that if FTTP delivers only a fraction of its potential service delivery capability, user sustained and peak bandwidths are going to increase and this could be several orders of magnitude compared to today's xDSL access networks.
- With the current network architectures, satisfying higher bandwidth in the core network plus the need to build an FTTP access infrastructure will significantly increase network costs – both OPEX and CAPEX. As mentioned above, the expected revenue growths are not sufficient to cover this cost increase. Therefore, we need to look at other alternatives for reducing the cost per customer so that the investment required is contained and network growth remains economically viable.
- There are two parts to solving the problem of increasing costs; one is to offset the access infrastructure build investment costs and reduced cost per customer by sharing the infrastructure over as many customers as possible and at the same time, use the lowest cost infrastructure sharing techniques. The second part of the solution is to minimise the number of electronic nodes, network interfaces, routers, switches and the traffic levels they need to process.
- Reducing electronics not only produces huge cost savings but also decreases the power consumption of the network. So the economic drivers also compliment the sustainability drivers and produce a “greener” solution. Also removing cost from the backhaul and core networks can help balance the increased cost of the access distribution network (from the cabinet location to customer) and fibre drop provisioning at the access edge.
- In the core network, node reduction and enabling transit traffic through core nodes to bypass electronic routers and switches can be done by keeping such traffic in the optical domain, and exploiting a **flat optical**

core whereby wavelength paths are setup across the network interconnecting the core nodes (or metro-core nodes as we refer to them in the DISCUS architecture). Thus traffic passing through a node stays in the optical domain and is not electronically processed, only traffic originating from or terminating on a metro-node needs to enter the electronic processing layers.

- We define an optical island as a set of nodes that can be fully interconnected by transparent wavelength routes. For large countries it is envisaged that multiple islands will be needed and these islands will be interconnected via a further “higher layer” optical island layer which interconnects the lower optical island through a small sub set of the metro nodes within those islands. The structure of the core network will be described in more detail in section 4. For many European countries it is envisaged that a single optical island may suffice and the next layer up would be a trans-European optical island providing interconnections between the in-country optical islands and the international routes to the rest of the world.
- The strategy for reducing cost per customer/user in the access network is infrastructure sharing over as many customers as possible and using a common infrastructure for all networks and services including wireless networks.
- Sharing the infrastructure also means sharing the resources including the usable bandwidth. This would reduce sustained or average bandwidth for users. To compensate for this we propose higher rate systems for the access network for example 10Gb/ symmetrical bandwidth Long Reach PONs (**LR-PON**).
- Greater sharing also means covering larger areas to capture larger numbers of customers on to a common shared access network. When this is coupled with the strategy of removing local exchange nodes and electronics from the network it means much longer reach access networks are required.
- The combination of longer reach, higher capacity and greater sharing of infrastructure logical leads to the use of **LR-PON**. So the resulting basic network structure for the DISCUS architecture is therefore **LR-PON** combined with **flat optical core** network.
- The strategy for extending core capability to the edge of the network is to use the wavelength domain and provide wavelength paths across the **LR-PON** common fibre infrastructure. These wavelengths can also be used to enhance access capacity for users connected to **LR-PON** systems. By providing a flexible wavelength domain with physical layer hooks into the optical hardware, flexible and evolutionary paths can be added at a latter stage to incorporate new and emerging technologies.

This combination of **LR-PON** plus **flat optical core** is the basic philosophy of the DISCUS architecture which we believe can economically deliver ubiquitous high speed broadband to all users and will ensure all optical points of presence deliver equivalent network and service capability irrespective of geographical location.

1.2 The End to End DISCUS architecture

A simple schematic of the DISCUS architecture is shown in **Error! Reference source not found.** It shows a dual homed LR-PON bypassing existing local exchanges and terminating on the metro-core nodes. The metro-core nodes are

interconnected with an optical circuit switched wavelength layer creating the optical islands.

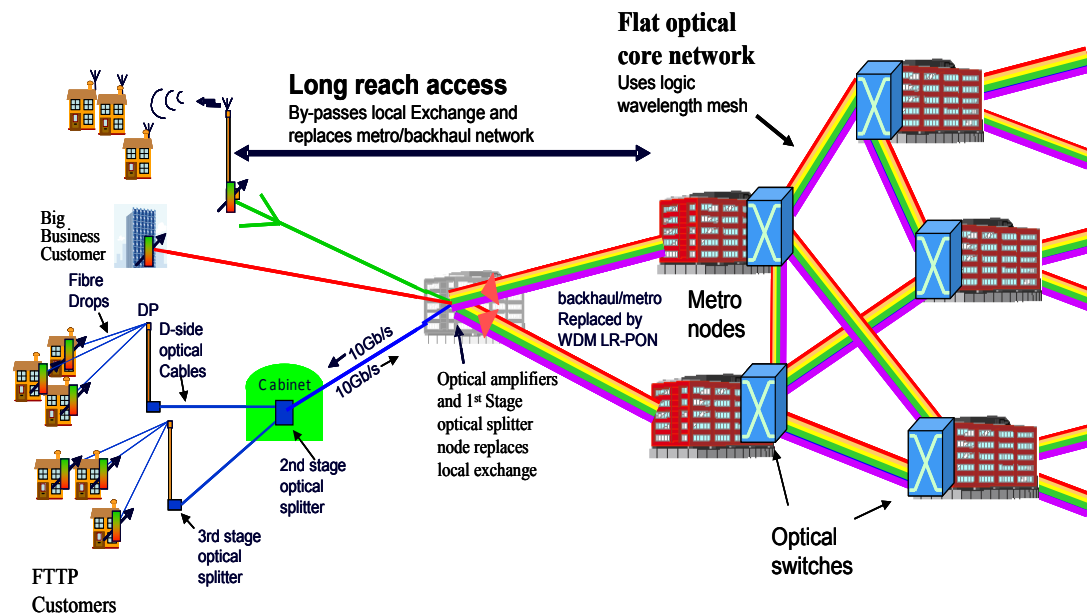

Figure 2 The end to end DISCUS architecture with LR-PON and flat optical core network

The overall architecture consists of three major parts; the **LR-PON** access network, the metro-core node and the **flat optical core**-network. Much of the design process for these parts of the network will be self-contained but an important aspect of the DISCUS proposal is that the architecture is an overall end-to-end design which steers the designs of the individual parts so that a coherent integrated design is achieved with optimal balance between the various parts, that is the DISCUS architecture is greater than the sum of its parts. The following sections examine the proposed initial architectures for the three parts discuss above.

1.3 The optical island concept

The concept of an “optical island” is a theme that runs through the DISCUS architecture and needs clarification. For the DISCUS project the term is also closely associated with a “flat optical core” network and is the idea that when the number of core nodes is sufficiently small they can be directly connected together via circuit switched optical channels without add-drop functions used at transit nodes (that is nodes that are physically traversed by the fibre route between a source and destination node but has no traffic dropped or added from that fibre path, or optical wavelength channel at those intermediate nodes).

An optical island can therefore be defined as that set of nodes that are fully interconnected by a set of optical channels (usually wavelength channels) without using a hierarchical structure. If the number of nodes increases to too

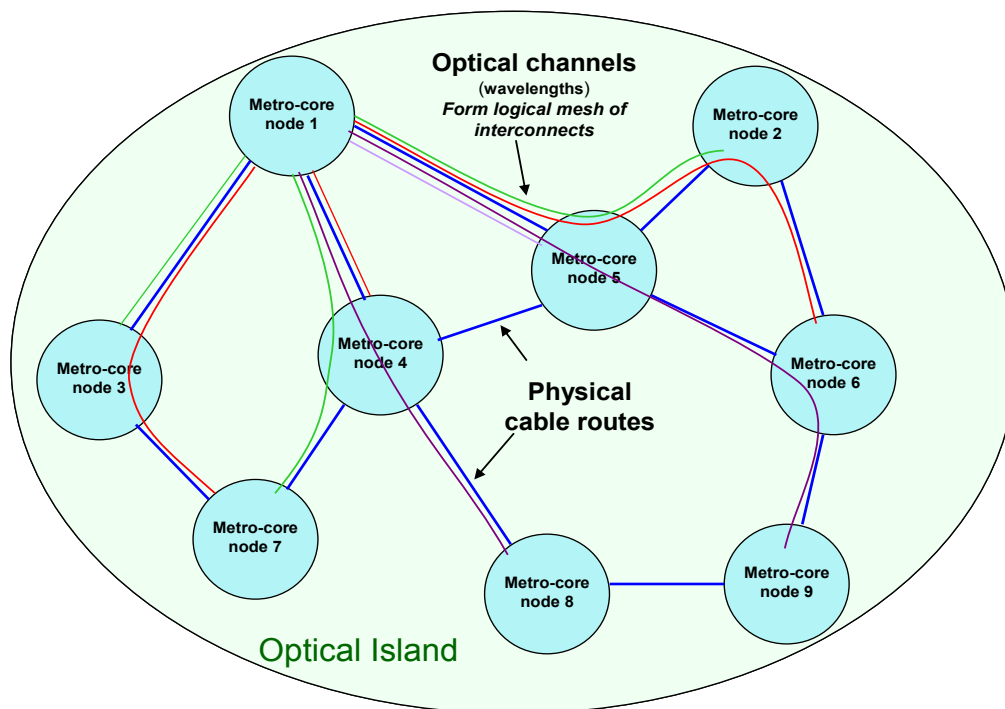

Figure 3 Optical island concept

large a number then a hierarchical core network would be required because of the N^2 scaling of the number of interconnecting optical channels required to fully interconnect the set of nodes. The advantage of the flat core is the reduction in OEO conversions and the reduction in switching, routing and packet processing in the metro-core nodes. The concept is illustrated Figure 3.

The metro-core nodes will be interconnected by a mesh of cable routes which for economic reasons will not be a full mesh. Overlaid on this is a full mesh of optical (wavelength) channels. In Figure 3 the blue lines are meant to represent cable routes and the coloured lines are the logical optical wavelength routes, shown only from metro node 1 to all the other nodes. These optical paths traverse other nodes but do not carry traffic for those intermediate nodes and simply pass through.

2 LR-PON optical access network

The strategy of increasing infrastructure sharing and also reducing network nodes inevitably leads to the Long Reach - Passive Optical Network (LR-PON) architecture for the access and metro networks. Using a LR-PON enables sharing of fibre infrastructure as close to the customer as possible using a passive optical splitting element that can fit into existing footway boxes or pole tops if required. This passive splitter requires no power and is a highly reliable component. The LR-PON uses optical amplification to support greater total split, longer reach and higher bit rates than today's PON solutions.

The higher split means that it is possible to have multiple split stages to further increase infrastructure sharing and minimise cost per customer. Locations for splitting points will be the distribution points (DP) close to the customer premises, primary cross connect (PCP) or cabinet locations, typically less than 1km from customers, and the local exchange or central office site where the optical amplifiers will also be located as this node has electrical power available. The average distance of customers from the local exchange will be of the order 2 to 3km but the tail of this length distribution can go out as far as 10km so the optical distribution network (ODN) from the old Local Exchange (LE) site is designed to support at least 10km as shown in Figure 4. however in sparse rural areas the ODN reach may need to be extended and alternative configurations will also be considered see section 2.6.

2.1 Initial DISCUS architecture - single fibre ODN, two fibre backhaul

The initial LR-PON design considered for DISCUS consists of a single wavelength upstream and downstream with single fibre (bi-directional) working in the optical distribution network (ODN) section from two fibre (uni-directional) working in the backhaul section. This choice is based on current practices where PON access networks are standardised on single fibre working while backhaul technologies are generally two fibre transmission links.

This design would use 1xN splitters at the DP and PCP (cabinet) locations. At the local exchange site there would be a 4x4 or possibly an 8x4 with up and downstream amplifiers on separate backhaul fibres.

The size and location of the first splitter (DP splitter) closest to the customer premises affects the distribution network (D-side network) costs and average LR-PON utilisation. A high utilisation is necessary to ensure maximum sharing the cabinet and LE site splitters and the feeder and backhaul fibre network. The size and location of the DP splitter depends on the customer density and is a trade off of cable fibre cost, optical drop cost, optical splitter size and the housing cost plus splices. The optimisation of this splitter size will be part of the modelling activities that will be carried out within DISCUS but a working figure of 16 or 32 way split can be used for the architecture design being considered in this report.

An important design issue for the specification of the optical splitter that is important for the architectural structure of the LR-PON is the number of optical ports on the network side of the splitters. The LR-PON design shown in Figure 4 uses 1 x N optical power splitters with only one fibre port on the network side of the splitter, an alternative design would be to use m x N splitters with m fibre ports on the network side of the splitters to provide greater flexibility. This greater flexibility can enable alternative designs and bespoke networks that might require smaller optical split, these architectural alternatives will be discussed later in the report. Figure 4 shows a WDM device in the metro core node connected to the up and down stream fibres of the LR-PON. However it may be important to minimise the capital investment for the initial system installation and only provide the minimum and simplest infrastructure for a single wavelength LR-PON at day one. Multiple wavelength operation will then be incorporated as part of a future evolution and upgrade strategy. This could mean that for a single wavelength system the WDM device at the metro-core node is omitted for the initial installation also the filter at the ONU is a fixed filter rather than a tuneable filter and the amplifier technology deployed at the LE site is limited to single wavelength capability to minimise cost.

At first sight it may be thought that if WDM devices are required in the future they must be fitted at day one to avoid major service interruptions while they are fitted. However this is not the case as the LR-PON basic design will have dual parenting protection and the non-traffic carrying path to the standby metro-core node can be upgraded first without any service disruption. Once this has been

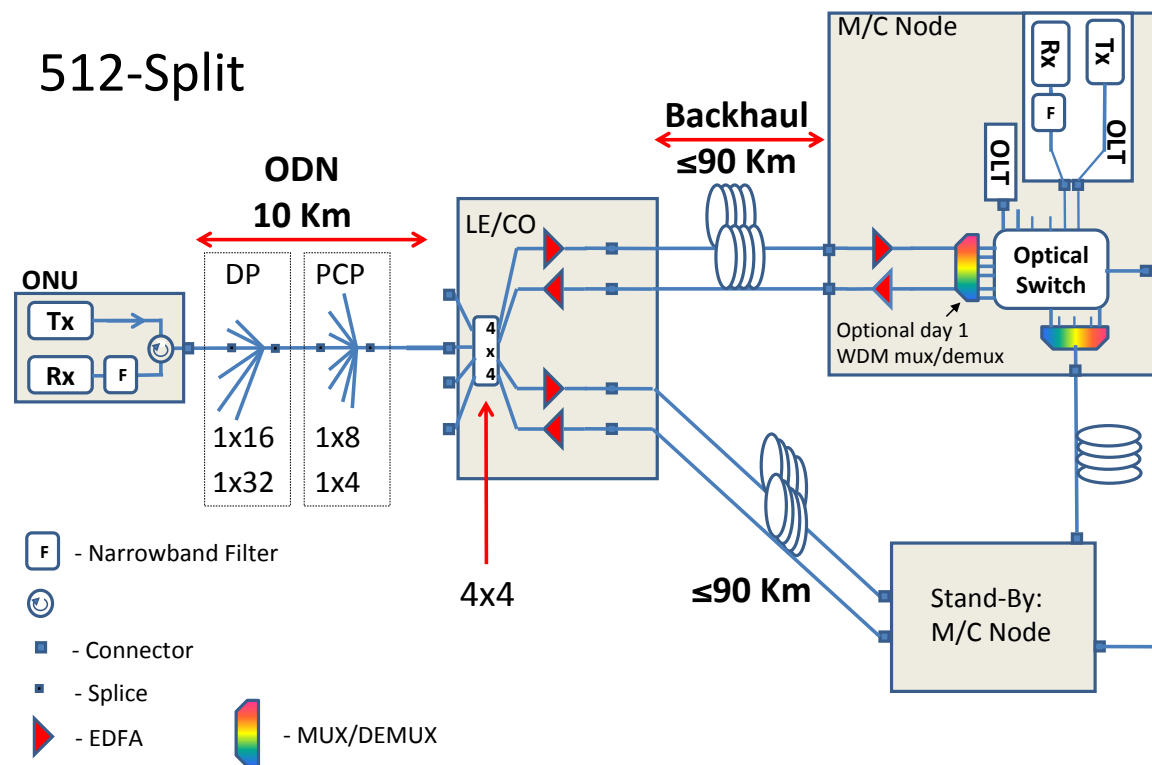

Figure 4 Basic LR-PON design with single fibre working in ODN and two fibre working in the backhaul

completed the working path can be switched to the upgraded standby path with

minimal disruption and then it can be upgraded in turn. A version of this process has been described in ref 2 and if the protection switching time can be kept to an absolute minimum (ideally less than 50ms) then service disruption will largely go unnoticed. Another alternative is to use the optical switch in the metro node to switch WDM devices to the access fibre when required.

Options for the optical switch architecture are discussed later in the metro-core node section, it should be noted that this is a different configuration from that shown in Figure 4 where the WDM device is inserted between the optical switch and the LR-PON backhaul fibre.

A circulator and a fixed filter are shown in the ONU in Figure 4 a circulator is used rather than a more conventional WDM diplexer so that a tuneable filter could also be used to provide flexible wavelength assignment at a later stage of development. Of course if the first system is a fixed wavelength system with wavelengths selected from the standard ITU grid within the C-band then a fixed wavelength diplexer could be used rather than a circulator. The design choice for the ONT will depend on the cost difference between a WDM diplexer and an optical circulator and the upgrade strategy adopted, for example will the ONU be changed out for future upgrades or will it be a modular design enabling upgrade of the ONT filter technology from fixed to tuneable technology? These various options for the LR-PON configuration will be examined in more detail as part of the design process within DISCUS.

2.2 Alternative LR-PON architectures

The basic architecture in Figure 4 uses the standard convention of single fibre working in the ODN part of the LR-PON network and two fibre working in the backhaul. Single fibre working has been the de-facto standard for the access network for many years now. The original driver came from point to point fibre solutions for the access network where halving the number of fibres in the high fibre count access cables had a major economic benefit. Even for low split PON solutions, such as current GPON and EPON, there is an economic benefit because of the limited infrastructure sharing gained by the low optical split of these systems. However, for LR-PON, which is a very fibre lean solution with a much higher split capability and therefore much higher degree of infrastructure sharing, the additional cost of two fibre working might not be significantly higher than single fibre working and might be offset altogether by removal of the diplexer devices in the ONT and OLT particularly when these need to work at DWDM tolerances when multi-wavelength LR-PONs are considered.

Although conventional single fibre working in the ODN with dual fibre working in the backhaul will be one of the key LR-PON architectures studied within DISCUS, alternative solutions such as two fibre in both ODN and backhaul and also single fibre in both ODN and backhaul will also be compared technically and economically.

2.2.1 LR-PON architecture – two fibre working in the ODN and backhaul

If a two fibre working design is used in the ODN as well as the backhaul network there is the major advantage that twice the number of wavelengths can be used for service provision compared to single fibre working, this additional doubling of available optical spectrum could prove to be extremely valuable in the future. Single fibre working in either the ODN or the backhaul network requires the available optical spectrum to be divided into two halves to provide the upstream and downstream wavelength channels, two fibre working avoids this.

512-Split

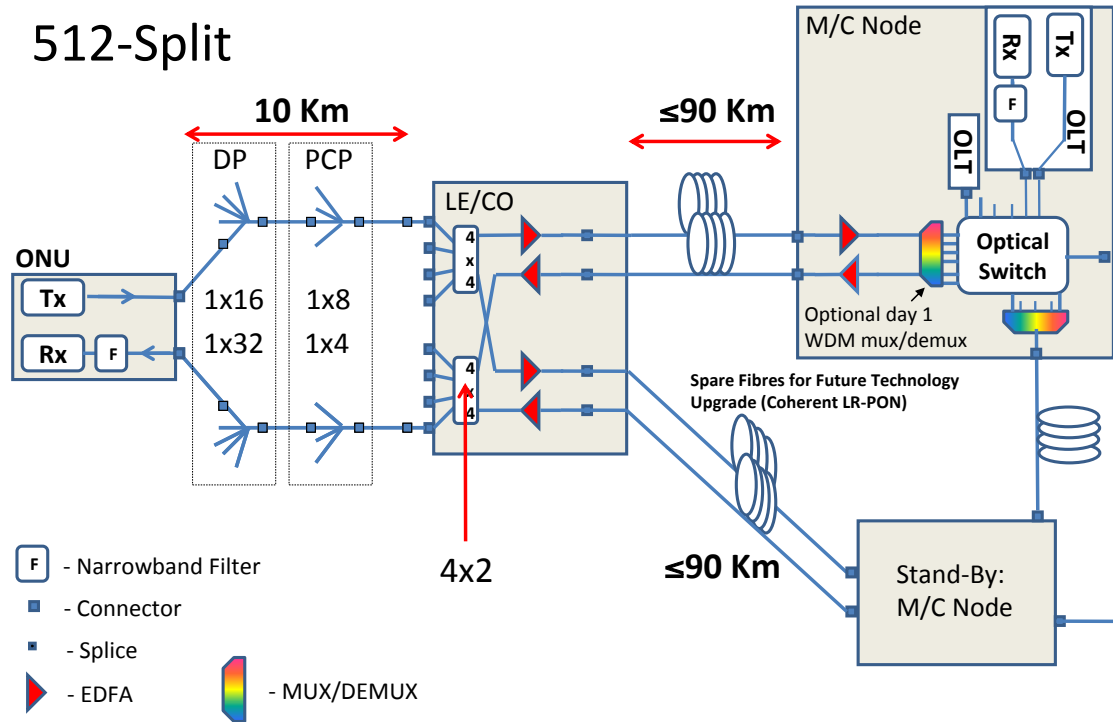

Figure 5 LR-PON architecture with two fibre working in both the ODN and backhaul

It will therefore be important to consider for the design of the initial LR-PON architecture whether to continue with the current practice of single fibre working in the ODN or whether two fibre working should be used in both the backhaul and the ODN part of the network.

A simplified system using two working fibres in both the optical distribution network (ODN) and the backhaul network is shown in **Error! Reference source not found.** This solution (and others) will be examined in more detail as part of the DISCUS design and modelling activities and its economic potential compared to single fibre ODN will be evaluated.

2.2.2 LR-PON architecture – single fibre in ODN and backhaul

As mentioned above single fibre working is the standard solution for the ODN in PON systems and the architecture for LR-PON as shown in Figure 4 for a single wavelength LR-PON would usually be assumed. However, single fibre working could also be extended into the backhaul which would have the advantage of releasing two spare fibres for use in future upgrades. A solution for single fibre working in both the ODN and backhaul parts of the LR-PON is shown in Figure 6.

Single fibre working is achieved in this solution by the use of optical circulators in the LE and metro-core nodes to separate the upstream and downstream paths and thus enable bi-directional optical amplification. There are also optical circulators used to provide the diplexer solution at the ONU. The OLT does not need a circulator as the diplexing solution is provided by the WDM devices that terminate the LR-PONs. This WDM device would have an upstream and down stream wavelength which would pass as two routes through the optical switch to the OLT. Circulators are required at the ONU in the customer's premises rather than the static WDM diplexers used in today's PONs because the DISCUS

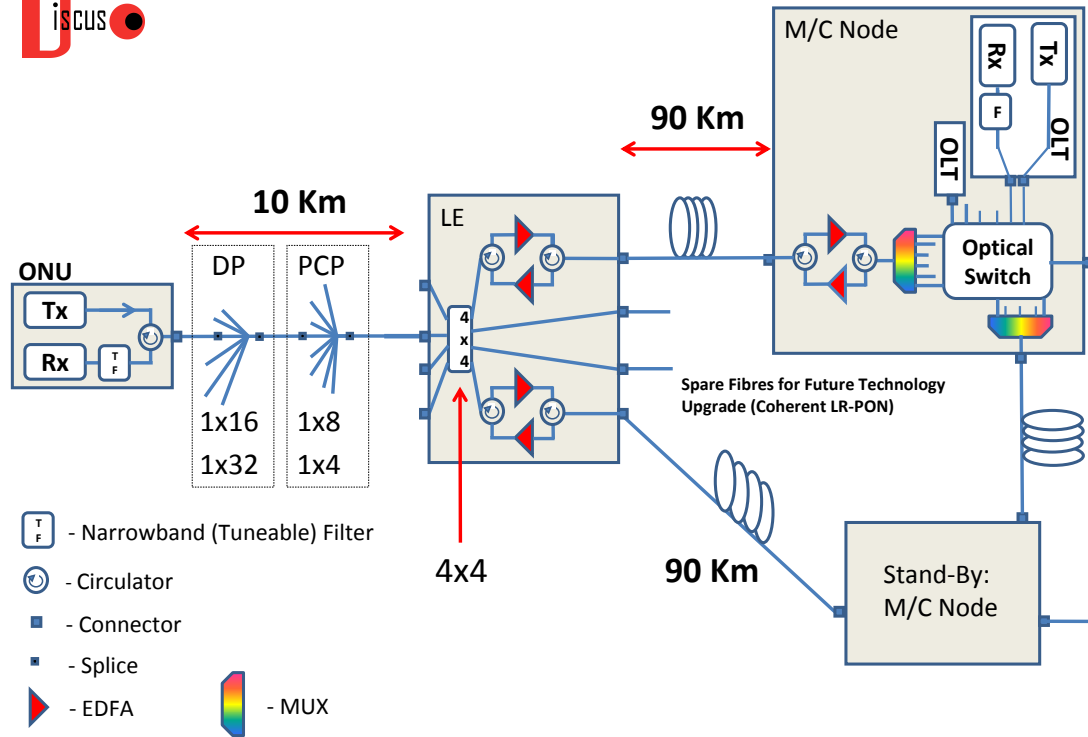

Figure 6 Flexible wavelength assignment LR-PON with single fibre working in both ODN and Backhaul

architecture includes flexible wavelength assignment which is enabled by the use of the tuneable filters and tuneable transmitters at the ONU and OLT as shown in Figure 6.

2.2.3 LR-PON architecture – Single fibre vs. two fibre comparison

The optimum choice between single fibre working and two fibre working in the LR-PON is not clear at present. There are a number of trade offs to be considered including economic analyses of fibre cost versus component cost, installation and maintenance costs trade-offs, future network evolution considerations and the value of the additional spectrum made available by two fibre working in both the ODN and backhaul part of the LR-PON network.

LR-PON solutions demand high-performance low-noise optical amplifiers and with current and foreseeable technology this means using EDFA amplifiers, which restricts spectral usage to the C-band with direct detection systems and L-band, with coherent technology which can also be used for longer term upgrade of the spectral utilisation. These comparisons and trade-offs will be considered and quantified, as far as possible, in the techno-economic modelling, service and traffic modelling and wavelength usage activities within the project.

Although the fuller analyses are still to be carried out a qualitative list of the pros and cons of single fibre working and two fibre working for the ODN and backhaul ports of the LR-PON are given in Table 1.

Table 1 Summary of advantages and disadvantages of single fibre or two fibre working in LR-PON

Options for single fibre and two fibre working	Advantages	Disadvantages

<p>Single fibre in backhaul</p> <p>Single fibre in ODN</p>	<p>Minimises splitter costs and fibre cost in both backhaul and ODN.</p> <p>Releases two fibres in the backhaul section which can be used for future upgrades.</p>	<p>Increased optical loss budget which will reduce system margins and may reduce split (i.e. loss of circulators required at amplifiers and diplexers at OLT and ONT).</p> <p>Extra cost of optical circulators.</p> <p>Reduced optical spectrum for service provisioning and system capacity by factor two.</p> <p>Possible non linear cross-talk in the backhaul</p>
<p>Single fibre in backhaul</p> <p>Two fibre in ODN</p>	<p>Reduced loss in ONU.</p> <p>Diplexer not required in ONU, reduced cost ONU.</p> <p>Releases two fibres in the backhaul section which can be used for future upgrades.</p>	<p>Increased cost of ODN fibre and splitters (In practice there may be no increased cost of fibre as LR-PON is very fibre lean and there will be spare fibre in the E-side and D-side cables and Drop cables).</p> <p>There will however be increased cost of fibre splitters (approx 1 additional splitter port per customer).</p> <p>Reduced optical spectrum for service provisioning and system capacity by factor two.</p>
<p>Two fibre in backhaul</p> <p>Single fibre in ODN</p>	<p>This would be considered to be a “standard” solution.</p> <p>Minimises splitter costs and potentially fibre cost in ODN.</p> <p>Reduced loss and cost in backhaul (no circulators).</p>	<p>Diplex (circulator) required in ONU, higher cost and higher loss.</p> <p>Reduced optical spectrum for service provisioning and system capacity by factor two.</p>

<p>Two fibre in backhaul</p> <p>Two fibre in ODN</p>	<p>Reduced loss and cost in backhaul and ONT (no circulators).</p> <p>Diplexer not required in ONT, reduced cost ONT.</p> <p>Full optical spectrum available up stream and down stream (doubles spectrum availability compared to other options).</p>	<p>Increased cost of ODN fibre and splitters (but see note in row 2 above).</p>
--	---	---

2.3 40Gb/s downstream for LR-PON

For the initial DISCUS architecture the LR-PON will be designed for 10Gb/s symmetrical operation. However as part of the evolutionary strategy for the LR-PON design 40Gb/s transmission in the downstream direction is also investigated as an upgrade option. To minimise the amount of electronic processing at the 40Gb/s line rate at the ONUs a bit interleaving protocol will be investigated

In order to upgrade to single carrier 40Gb/s downstream, two main technical challenges at 40Gb/s need to be addressed: electronics operating at higher speed, and the need for more optical power to maintain OSNR. As in previous steps in the evolution of TDM-PON, these challenges will be aided by Moore's Law and improvements in optical component technology.

2.3.1 40Gb/s down stream transmission

In addition, at 40Gb/s, chromatic dispersion (CD) becomes a more serious challenge. The 4x increase in bit rate increases transmission-limited CD by a factor of 16 compared to 10Gb/s. So far, several dispersion compensation techniques have been proposed in literature: a pre-chirping optical transmitter,

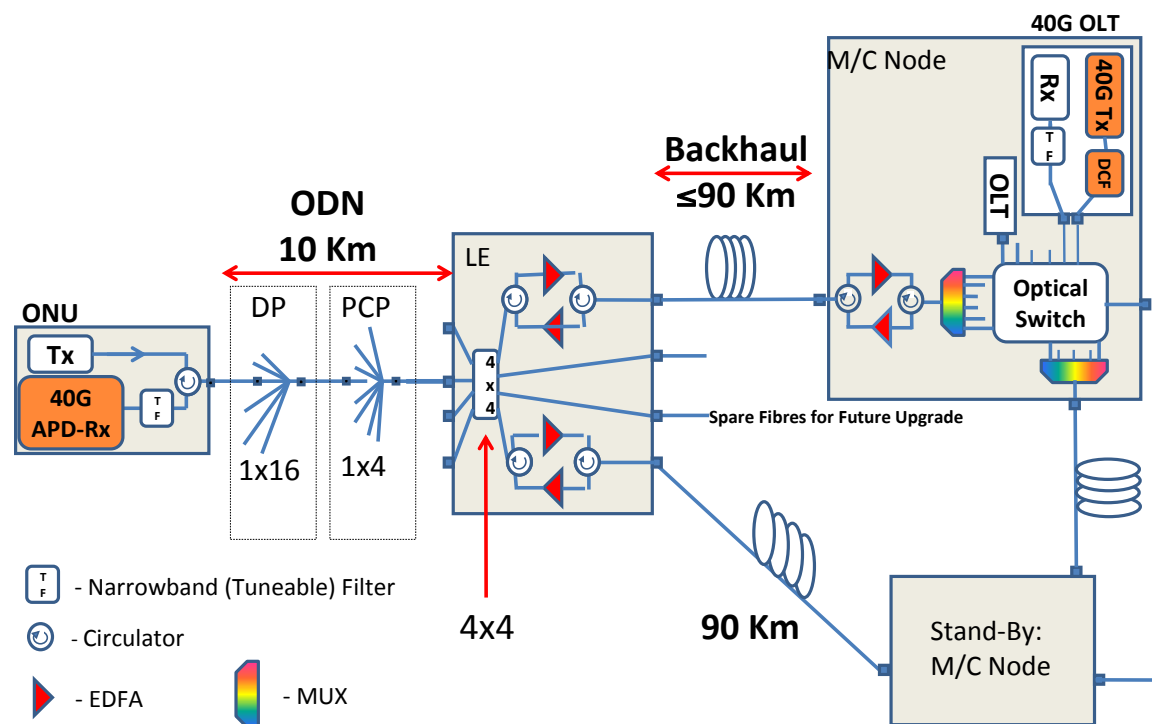

Figure 7 40Gb/s downstream LR-PON with single fibre working in both ODN and backhaul

electronic dispersion compensation (EDC) at transmitter/receiver, dispersion compensation fibre Bragg grating and dispersion compensating fibre (DCF).

Our initial investigation is to use a DCF module inserted at the 40G OLT output to compensate the chromatic dispersion of the feeder fibre. We also propose a 3-level electrical duobinary modulation scheme to reduce the optical bandwidth of

the OLT transmitter and ONU APD receiver. We choose 3-level electrical duobinary because its implementation for modulation and demodulation is simple, and because its degradation of receiver sensitivity relative to NRZ is minimal ($\sim 3\text{dB}$ at $\text{BER}=10^{-3}$). The proposed modulation reduces the downstream channel bandwidth requirement to $\sim 20\text{ GHz}$, which requires a 25Gb/s APD at the ONU. The reduced optical bandwidth of the 3-level electrical duobinary also serves to further improve the CD tolerance of the 40G downstream.

The 40G downstream topology with ONU APD receiver shown in Figure 7 has been analysed in terms of power and OSNR budget. Since FEC is commonly employed in 10G -class PON systems to improve the optical link budget, we assumed a similar pre-FEC threshold BER of 10^{-3} for the 40G receiver sensitivity estimation. The analysis shows that the 40G downstream performance is not OSNR limited but is limited by the optical power level at the ONU receiver. To maintain the receiver SNR while increasing the bit rate by a factor of 4 requires nominally 6 dB more optical power. One solution is to increase the output power of the optical amplifier in the local exchange to delivery as much power as possible to the access section. However, the output power of downstream EDFA in LE is limited by eye safety, cost and potentially stimulated Brillouin scattering. In the worst-case, assuming the same output optical power achieved as the 10G scenario, the supported split ratio in the access section reduces from 512 - to 128 -split ($\sim 6\text{ dB}$).

2.3.2 40Gb/s down stream transmission using ONU with SOA

To restore the split level back to 512 ways, a combination of a higher power LE downstream EDFA and a semiconductor optical amplifiers (SOA) preamplifier

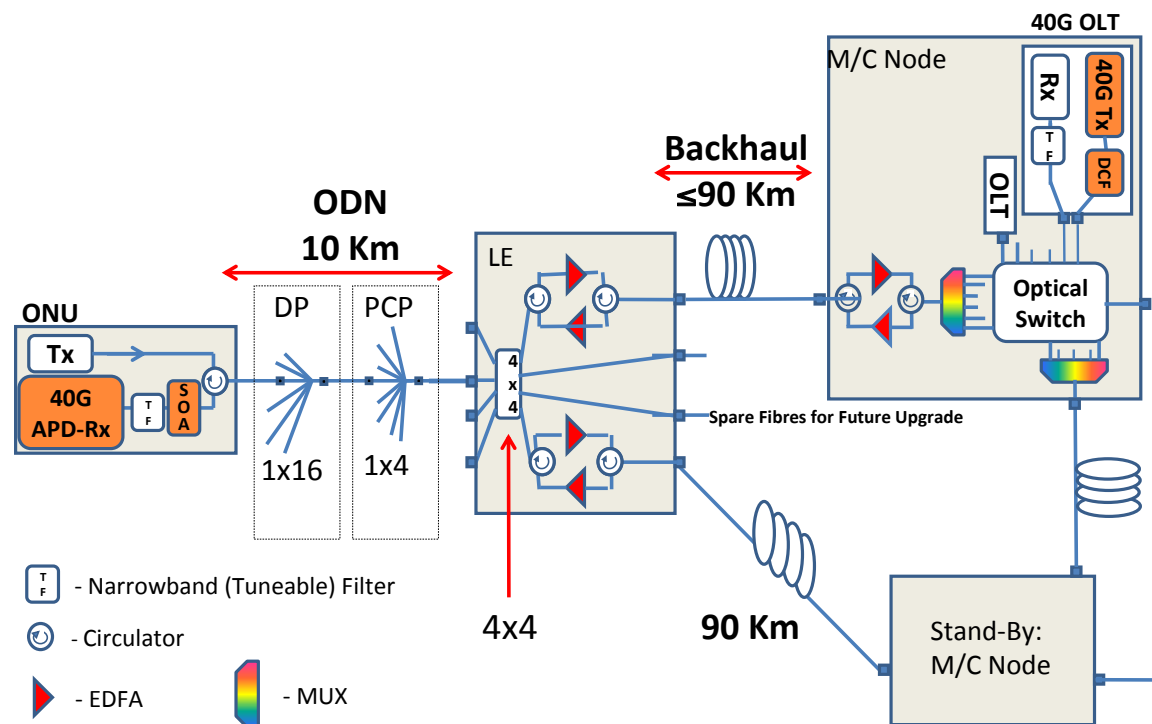

Figure 8 40G downstream LR-PON with SOA-preamplified PIN-Rx at ONU

with PIN ONU receiver at the ONU is proposed, as shown in Figure 8

The compact size and the possibility of integrating the SOA makes it a suitable candidate for an optical preamplifier in the ONU. SOAs have a higher inherent noise figure than EDFA and the ONSR of the topology shown in Figure 8 has been modelled given a typical SOA preamplifier with small-signal gain of 17dB and noise figure of 7.5dB. The power and OSNR results suggest that the downstream is still not limited by the OSNR and a split of 512 might be feasible in this topology with a small system margin.

To achieve further system power budget and margins, a combination of the following techniques will also be considered:

- A stronger FEC scheme. This becomes possible as the FEC decoder only needs to operate at the user rate (due to use of a bit-interleaving protocol), instead of the aggregate 40 Gb/s line rate.
- A pre-chirping transmitter to offer some relief for dispersion compensation, reducing the length of the DCFs (also the cost) and the insertion loss of the DCFs.
- EDC at ONU receiver to compensate the chromatic dispersion caused by different access reach and improve the dispersion tolerance.

These techniques will be considered further as part of the design work within the project.

2.4 LR-PON resilience options

This section describes some options for resilience in LR-PON design. It mainly focuses on the physical layer aspects but there are also considerations concerning the protocol and fast re-ranging [2] and layers 2 and 3. These will be reported later in future deliverables.

2.4.1 *Basic dual parenting protection for all users*

In the architectures shown in Figure 4 to **Error! Reference source not found.** the long backhaul part of the network is protected by having a working and standby route to two separate metro-core nodes. The protection routes are enabled by having additional ports on the network side of the optical splitter in the amplifier node so that rather than having a 1 x 4 splitter a 4 x 4 splitter is used. By having the extra ports provided as a part of the splitter there is no additional loss penalty

This means that it is imperative to decide on the number of upstream ports required at the initial design and implementation phase and not add upstream ports as successive upgrades. At the amplifier node this is implemented at day one by providing a 4x4 or 8x4 splitter. A similar issue occurs in the access portion. One option is to simply install 1xN splitters at the cabinet and distribution point splitters, because, for the majority of users, operators do not usually provide additional protection in this part of the network. However this might not be adequate for all users and simple 1xN splitters might hinder the ability to increase protection for a subset of customer that require higher resilience. Thus a study is required to understand whether additional network side splitter ports may need to be installed at day one.

From the network design point of view, protection techniques such as OLT dual parenting and dual-homed feeder fibres (and ducts) are an intrinsic part of the DISCUS LR-PON architecture as illustrated in Figure 4 to Figure 8. This basic dual parenting technique can protect a large number of end users from backhaul fibre link failures, optical amplifier failures and OLT failures, while the additional deployment cost for providing protection can be shared by all the connected customers. However it has been shown in [3] that the protection of the feeder fibre alone may not be sufficient since it is not able to guarantee connection availability performance greater than approximately 99.99%. For very demanding applications some business users require greater availability than the basic 4 nines availability provided by simple dual parenting as described above. Therefore, to satisfy more stringent requirements from the more demanding users of the network, different levels of resiliency should be provided in LR-PON, i.e. basic feeder fibre protection for residential users and increased connection availability for users who are willing to pay more. Thus, if possible, the DISCUS architecture should support flexibility in deployment of the ODN fibre protection in order to offer increased resilience for users that demand greater network availability.

The basic dual parenting and protection for all users of the back haul link is shown in Figure 9 and the principles apply to all the architectural configurations shown in Figure 4 to **Error! Reference source not found.**

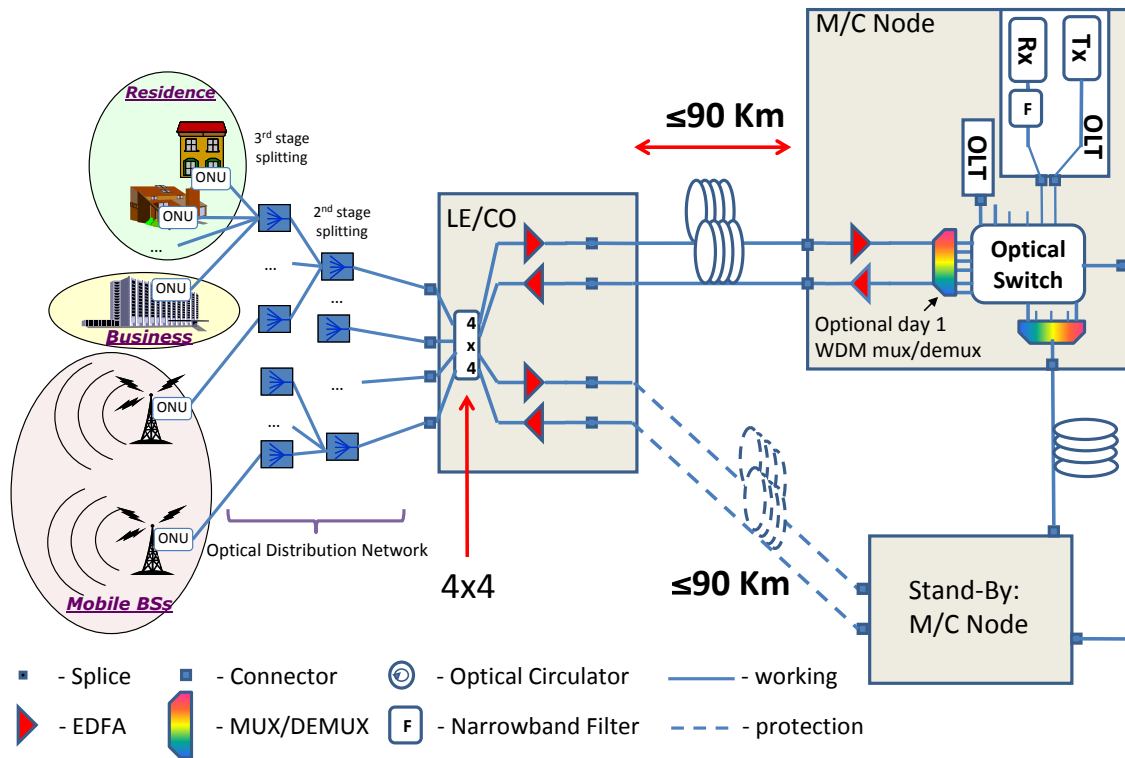

Figure 9 OLT and backhaul fibre protection for all users

2.4.2 Improved protection via two paths through the ODN

To enhance the protection of the basic DISCUS architecture and provide differentiated protection in LR-PON, customers requiring further protection can have two ONUs provided at their premises which are connected to different branches of the same LR-PON ODN network, this is shown in Figure 10. This solution enables additional protection against faults in the ODN network. The difficulty with the solution proposed in Figure 10 is ensuring geographically disjoint paths for the different branches of the ODN fibre. The problem is that there are usually only two or three disjoint paths out of the old local exchange/central office site and these usually feed distinct geographical areas of the local exchange serving area. Therefore providing disjoint paths through the ODN may require additional civil works to interconnect different parts of the ODN network. Further work on real fibre layouts will be required to assess the cost and engineering difficulty of ensuring such disjoint paths in the ODN.

A further problem when using disjoint paths that are routed over the same LR-PON is that there is still a single point of failure at the amplifier node at the old local exchange site. The amplifiers themselves are protected via the working and standby paths to the dual parented metro-core nodes so the availability of this node will be very good, but further protection for some customers may still be required.

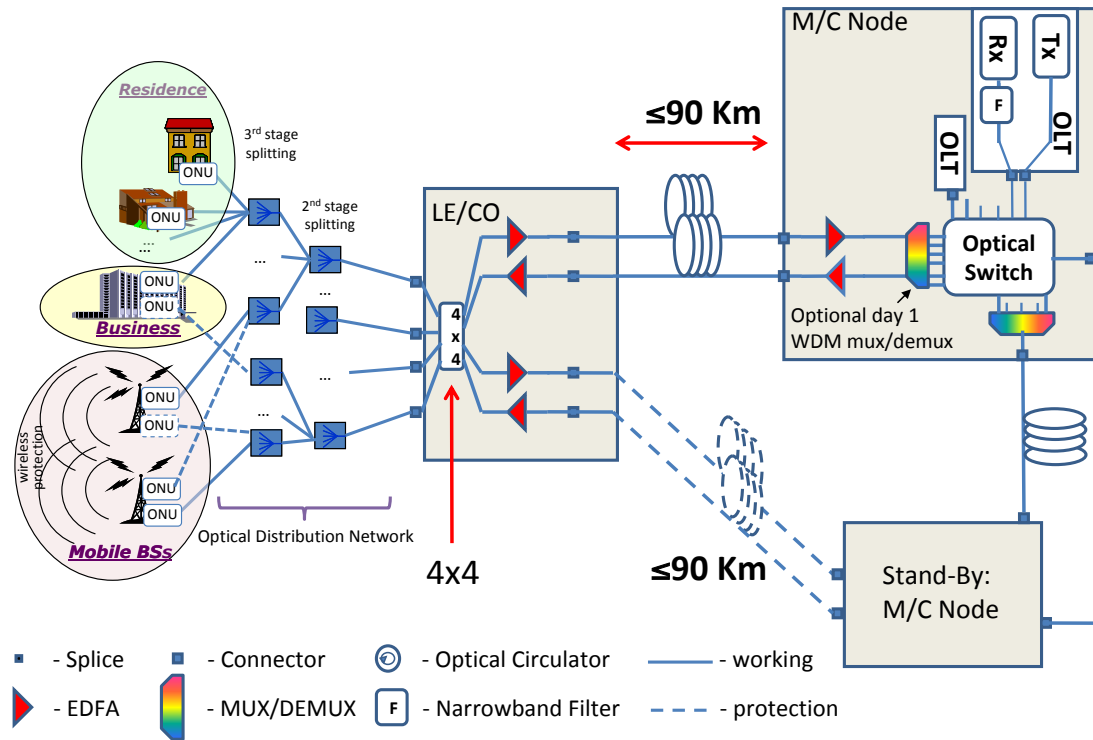

Figure 10 Increased protection for some users

2.4.3 Full protection via two separate LR-PON connections

A typical method used to provide improved resiliency to some selected LR-PON customers is a 1+1 duplication of the entire link, from two separate ONUs at the customer premises to two OLTs at two separate metro-core nodes via geographically separate LR-PON fibre and cable infrastructure as shown in

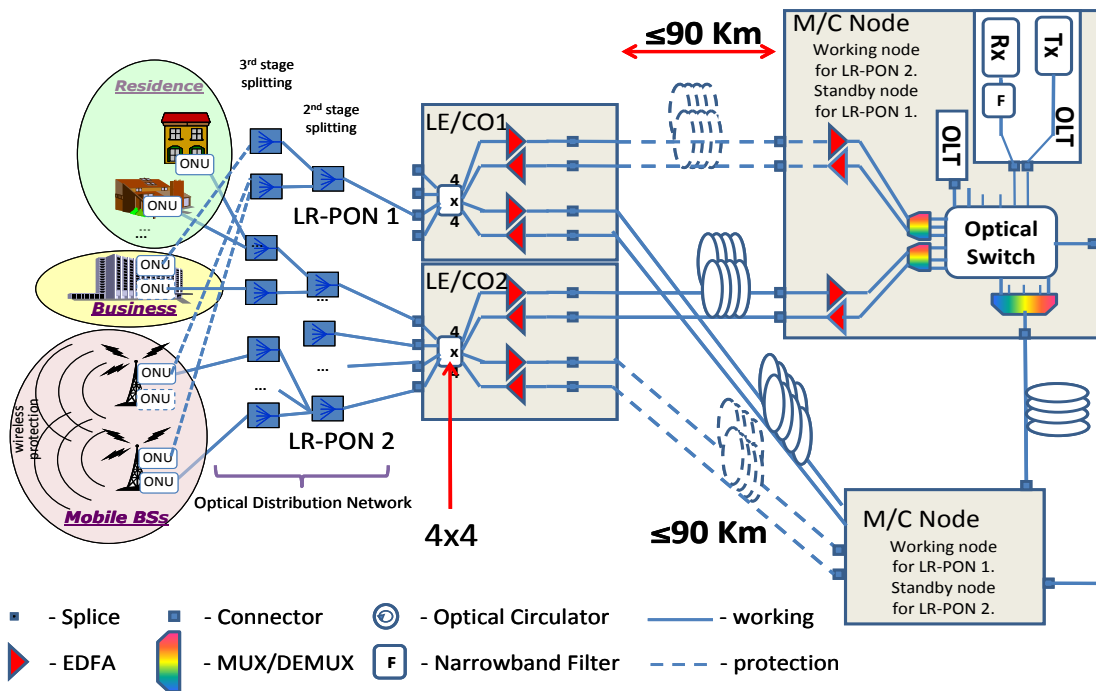

Figure 11 Full Protection for Business Access and Mobile Backhaul

Error! Reference source not found..

This solution has the advantage of having the protection path passing through a different amplifier module. Ideally for maximum protection the protection standby amplifier node would be located in a separate LE site this would require the greatest amount of additional infrastructure to guarantee complete geographical separacy and would therefore be the most expensive option. A lower cost option would be to place the protection amplifier node in the same LE as the working node. This is better than the solution in Figure 10 but still suffers from the possibility of complete LE node failure taking out both protection and working paths.

The working and standby paths from the local exchange site would usually be the same route for all LR-PON connected to that local exchange site; however a further level of protection against backhaul cable cuts would be to have a mix of working and standby paths on each of the two connected metro nodes. This is illustrated in **Error! Reference source not found.** by having the working path of LR-PON 1 going over the standby path of LR-PON 2.

2.4.4 Summary of protection options for LR –PON:

- Basic protection for all customers via dual parenting of last splitter and amplifier node onto two metro-core nodes - Figure 9.
- Enhanced protection via two ONUs at the customer premises, the second ONU connected to last splitter and amplifier through a separate branch of the LR-PON ODN – Figure 10.
- Fuller protection via two ONUs at the customer premises and the second (protection) ONU connected to a separate LR-PON - **Error! Reference source not found..**

2.5 LR-PON optical power budgets

The use of EDFAs at the local exchange site splitter point enables longer reach, larger total split and higher bitrates over the LR-PON. The greater the optical split the greater the sharing of fibre infrastructure and network technology and systems. This reduces the cost per customer and provides a means of transferring capital expenditure from the upper reaches of the network to the final drop and customer termination while maintaining overall economic viability.

It is important to maintain a high split ratio as the highest per customer cost is the final drop from the first splitter location at the DP to the customer and the associated customer termination plus optical network termination unit (ONT or ONU). In practice this optical drop and network termination cost is difficult to reduce and is similar for all FTTP solutions. An objective of the DISCUS architecture is to reduce the cost per customer of the network infrastructure above the distribution point (DP) by sharing infrastructure as much as possible, to help offset the high cost per customer of the last drop and optical termination. Maintaining high split is therefore an essential feature of the LR-PON network design, the impact of LR-PON split on cost will be quantified in the economic analysis being carried out within the project.

The limitations on optical split are the optical power budget and the optical signal to noise ratio (OSNR). In the upstream direction the limitation is OSNR which is limited by the noise from the optical amplifiers, mainly caused by amplified spontaneous emissions (ASE). EDFA amplifiers typically have the lowest noise figure for a pragmatic, moderate cost optical amplifier for use in the access network and will be required to maintain the large split necessary for the LR-PON design. However as mentioned previously this limits the optical windows available for WDM upgrade to the C-band and possibly the L-band although EDFA's designed for use of this band will not provide the same reach and split level as those designed for the C-band, however the L-band will be very useful when coherent transmission technologies are used.

The topology shown in Figure 6 is one of the topology scenarios that have been analysed in terms of power and OSNR budget. This topology refers to a densely populated area where a large number of customers are grouped within a short distance (10km in the Figure 6) and would have been served by a single local exchange, which is located up to 90km distance from the metro core node.

The analysis of the power and OSNR budget has been performed under the assumption that within DISCUS the linear burst-mode receiver (LBMRx) technology developed by the Tyndall research group will be employed. The LBMRx requires 15 dB OSNR at dynamic range of 20dB to achieve BER=10⁻³ (at 10Gb/s). Hence, for this initial study we used 15dB as the minimum (end of life) OSNR target. Another assumption in this analysis is that FEC will be used in the upstream. All the component losses used are derived from the GPON standard in the ODN and from datasheets of commercial components for the ODN, amplifier node and backhaul link.

The results from the power and OSNR modelling suggest that a split of 512 can be supported with on-off keying (OOK) modulation of the optical signals at 10Gb/s in both directions. The architecture in Figure 6 is fully reconfigurable as it does not restrict in any way the wavelength allocation to and from the ONUs.

It should be noted, however, that due to the long metro section (90km) the upstream launched power from the LE should be relatively high in order not to incur an OSNR penalty, in the order of +15dBm. This would require the use of a high power EDFA in the upstream in the LE which could cause issues in terms of non-linearities in the metro fibre. The launched power from the LE into the access section is also high (+15dBm) due to the high split ratio and an APD would be required in the ONT for the downstream receiver. The 4x4 splitter in the LE reduces the non-linearity concerns and this could be increased to an 8x4 to further reduce non-linear impairments. If this proves necessary, this would be at the expense of more feeder fibre in the ODN section. One potentially serious non-linearity is Stimulated Brillouin Scattering (SBS) which can be a serious problem if narrow line width optical sources are used with modulation schemes such as OOK that have a significant carrier component in the transmitted optical signal. SBS limits the effective launch power that can be used but it can be mitigated by techniques such as dithering of the optical carrier which effectively broadens the optical line width without incurring additional dispersion penalties. Figure 12 shows the SBS threshold [4] for SBS against dither frequency for a range of standard G652 fibre lengths.

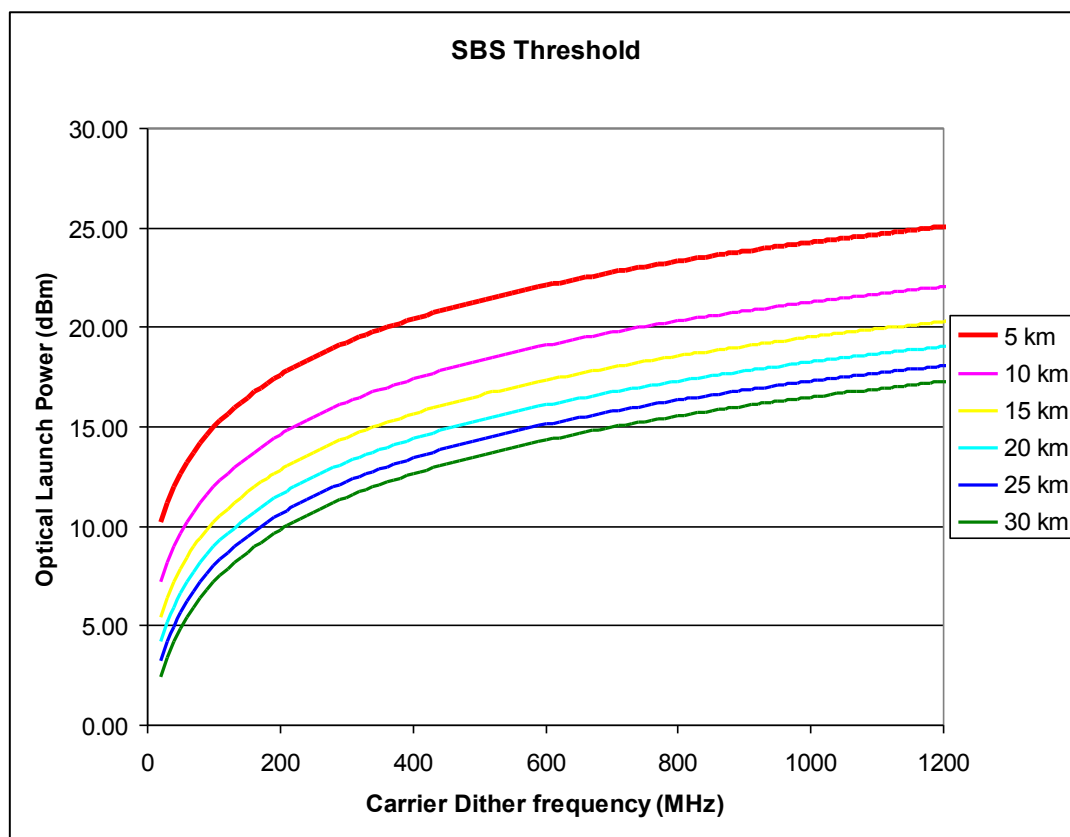

Figure 12 Stimulated Brillouin scattering threshold

Figure 12 also shows the SBS threshold dependency on fibre length and for rural areas the feeder lengths will be longer than the 10km maximum suggested in the architectures shown in Figure 4 to **Error! Reference source not found.**

When WDM is operating over the LR-PON the high launch power for each wavelength is likely to produce additional non-linear effects such as four wave mixing. Non-linear aspects of the LR-PON will be considered as part of the detailed design process particularly for the DWDM applications and transport of core wavelengths over the LR-PON infrastructure.

2.6 Rural or sparse population solutions

A feature of the LR-PON designs shown in all the architecture in Figure 4 to **Error! Reference source not found.** is that the majority of the long reach section is assumed to be in the backhaul part of the network with the optical distribution network only occupying the last 10km. This may be adequate where the number of customers at the end of the LR PON route is sufficient to give good utilisation of the LR-PON, but in sparse rural areas this may not be the case and it will be necessary to connect to customers at different points down the feeder route. This has major complexities for the optical design of the LR-PON particularly for the placement and design of the optical amplifier nodes.

2.6.1 Rural areas LR-PON design option – increase ODN length

One, apparently obvious, way of increasing the ODN feeder length to service sparser rural areas would be to trade off backhaul length for ODN reach,

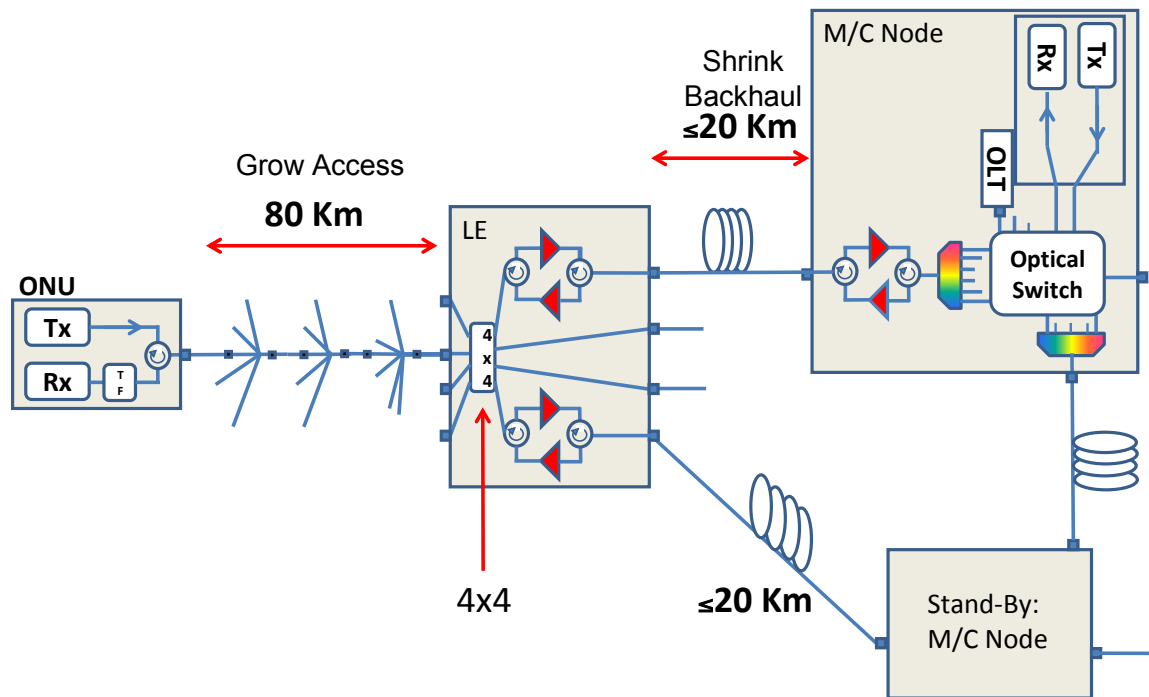

Figure 13 Sparse Rural Region, simple solution - grow access, shrink backhaul

effectively moving the amplifier node towards the metro node. Such an option is shown in **Error! Reference source not found.** where the ODN reach has been increased to 80km and the backhaul reach reduced to 20km. In practice however this has limited application due to the relationship between ODN reach and LR-PON split for a given power budget, as illustrated in **Error! Reference source not found.** which show LR-PON split as a function of ODN reach.

From **Error! Reference source not found.** it can be seen that if the ODN length was increased to 80km then the total split would be reduced to approximately 8 which would not be practical from an economic point of view (note the apparently flat region in **Error! Reference source not found.** between 50km and 60km reach is simply that the increased power budget at 50km from 60km was less than 3dB and therefore could not realise another doubling of split). However this scheme may be applicable to some very sparse areas where the total reach is not so demanding. For example if the ODN reach in **Error! Reference source not found.** was halved to 40km the LR-PON split would be 64 way which is comparable to currently deployed short reach PONs.

The practical applicability of this simple rural solution will be investigated further as part of the modelling activities in DISCUS. Alternative LR-PON architectures will also be investigated and compared for real geographic regions

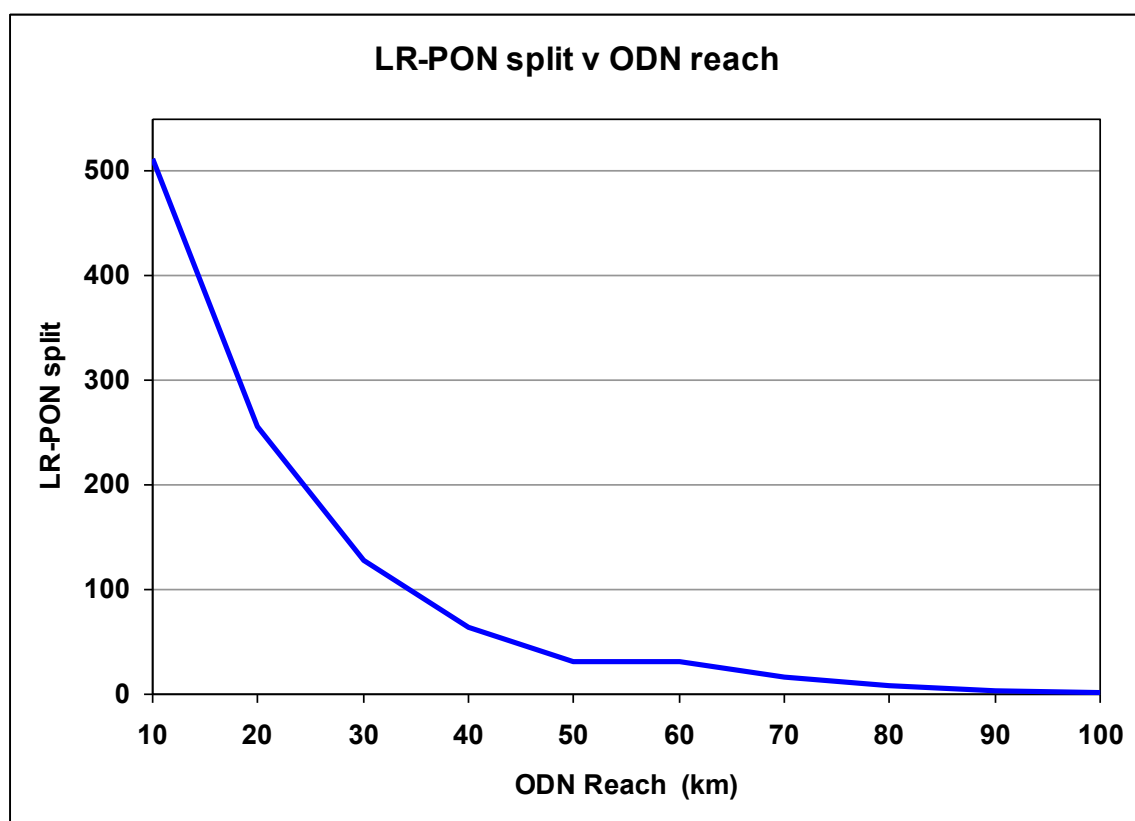

Figure 14 PON split reduction as ODN length increases

and population distributions. The sparse regions of Ireland will be investigated as an example of some of the most sparsely populated areas in Europe. These will be compared to the UK which is the most densely urbanised country in Europe.

2.6.2 Rural areas LR-PON design option – Multiple ODNSEctions

An alternative architecture for rural situations is shown in **Error! Reference source not found.**. In this approach the backhaul is subdivided into a number of shorter sections and a number of amplifier nodes are providing a proportion of

of the first EDFA in the chain, the OSNR can be improved. As an example an OSNR margin of 4.4dB can be obtained by increasing the gain of the first EDFA by 5dB, which would increase the dynamic range to 19dB. It should also be noted that the required launched power from the LE would be reduced compared to the previous cases, +2dBm per channel for 1.6dB OSNR margin and +7dBm per channel for 4.4dB OSNR margin, which would greatly reduce the impact of fibre non-linearities, and it would also allow the use of multi-channel EDFA with standard aggregate output powers, around +15 and +20dBm, respectively.

2.7 Amplifier node design issues and options

The amplifier node is an important feature of the LR-PON it enables bypass of the local exchange equipment required for today's copper and short reach access networks. The Amplifier node will be placed at the location of the local exchange site where electrical power would be available. However a major objective of the DISCUS architecture is to enable closure of these buildings and therefore arrangements would need to be made for access to electrical power at the site even when the building has been closed for telecommunications use.

The amplifier node will therefore need to be placed outside of the equipment rooms of those buildings and either into the outside exchange manhole or the cable chamber, if external access is available or can be arranged. These issues are organisational and process oriented and are beyond the scope of the DISCUS project, however a consequence of placing the amplifier node in a relatively small space such as the cable chamber or exchange manhole) requires that the design be both small and low power consumption and probably environmentally sealed (manholes can flood) and being seal attention will need to be paid to thermal design and management.

Key features for the design of the amplifier node in addition to the optical design parameters are; management, power feed, battery back up, maintainability of the node and evolvability/ upgradability,.

The design will be an iterative part of the LR-PON design and the overall design of the DISCUS architecture. In this section we described some initial options for the design of the node.

2.7.1 Amplifier node for single fibre ODN and two fibre backhaul

The amplifier node for the basic LR-PON design shown earlier in Figure 4 has the conventional single fibre working in the ODN and two fibre working in the backhaul parts of the LR-PON. In this design different outputs of the 4x4 splitter are used to separate the up and downstream paths, which would then be connected to separate fibres in the backhaul cables. It should be noted that the EDFAs include isolators in the modules and effectively block the transmission in the opposite direction.

Figure 16 shows an example of an amplifier node configuration for this solution. An optical tap is placed on the ODN side of the 4x4 splitter to access the optical signals for operations and maintenance functions. The tapped optical signals are fed to what is essentially an ONU and enables management messages to be passed between the amplifier node and the OLT at the metro-core node. The optical tap can be very low loss in the main ODN path as the optical signal power level at this point will be very high, of order +9dBm so an optical 100:1 optical tap could be used.

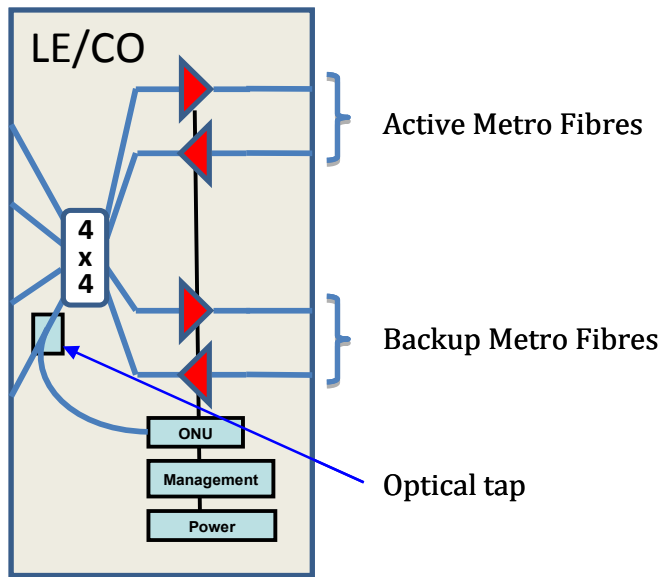

Figure 16 Amplifier node for conventional LR-PON with single fibre ODN and two fibre backhaul

In general a local exchange site will have a number of LR-PON systems and it would be expected that the amplifier node will be modular and able to flexibly accommodate a number of amplifier modules for the LR-PONs required to serve the LE site. This gives the opportunity of sharing some components such as power supplies and battery back-up systems and possibly the management ONUs on a shared protection basis to improve reliability of the node. These schemes will be examined as part of the design process and the

solutions compared from a cost and reliability perspective

2.7.2 Amplifier node for single fibre ODN and single fibre backhaul

An example configuration for an amplifier node that enables single fibre working in both the ODN and backhaul parts of the LR-PON is shown in Figure 17. Single fibre working in the backhaul path requires bi-directional amplification of upstream and downstream paths and can be achieved by using optical circulators to enable two separate upstream and downstream optical amplifiers to act as a bi-directional amplifier. There will be a small additional loss introduced by the circulators and also the cost will be increased due to the need for the circulators. Whether the additional cost is warranted will depend on the cost saving of the reduced backhaul fibre. These comparisons will be factored into the economic analyses to be carried out later. In all other

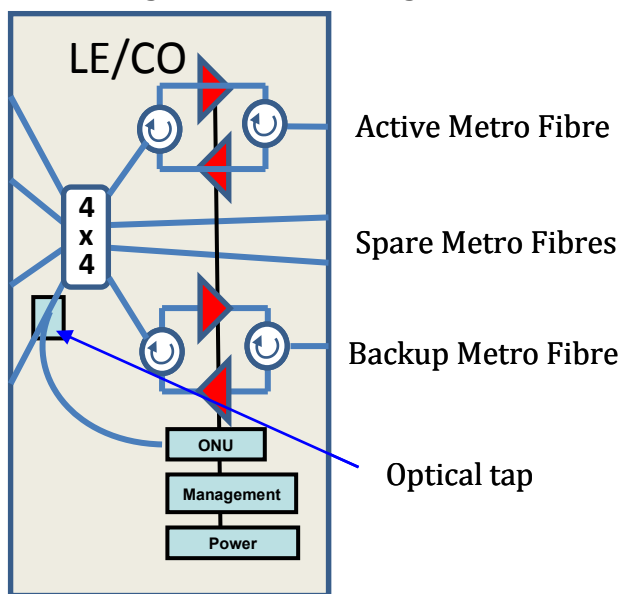

Figure 17 Amplifier node configuration for single fibre ODN and backhaul

respects this amplifier node is the same as the design for single fibre ODN and two fibre backhaul as shown in Figure 16.

2.7.3 Amplifier node for two fibre ODN and two fibre backhaul

For two fibre working in both the ODN and the backhaul parts of the LR-PON a configuration such as that shown in **Error! Reference source not found.** could be used. In this configuration of the amplifier node the 4x4 splitter is divided into two 2x4 splitters for the upstream and downstream directions of propagation. The management ONU does not need a diplexer but does need to be connected to both the upstream and downstream 4x2 splitters via two optical taps as shown in **Error! Reference source not found.**

The configurations shown in Figure 16 to **Error! Reference source not found.** differ only slightly in the components used and will be of similar cost as the main cost elements will be the optical amplifiers and the management and control electronics. There are no wavelength selective elements in the above

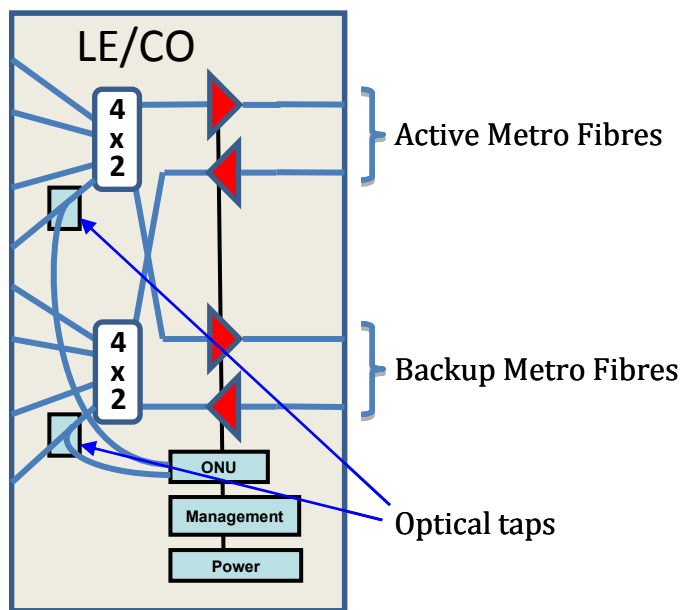

Figure 18 Amplifier node configuration for two fibre working in the ODN and backhaul parts of the LR-PON

configurations and therefore they can all be used to support WDM operation, but as discussed previously there is a design decision to be made concerning the performance of the amplifiers for the initial deployment. To keep costs to an absolute minimum the first installed amplifiers may only be provided with sufficient performance for a single wavelength LR-PON system and would need to be upgraded when WDM is required. The upgrade can be carried out with minimal disturbance to the working customers by upgrading the standby path first and then

switching the working path to this upgraded path. The working path can then be upgraded and when all work is complete the working path can be restored.

- A design choice for the early system deployment is therefore whether or not the first optical amplifiers installed should have sufficient performance to support WDM upgrade or whether simpler amplifiers designed only for single wavelength working of the initial LR-PON should be deployed.

2.7.4 Amplifier node example using WDM components

Alternative designs to those shown in Figure 16 to **Error! Reference source not found.** would be to introduce wavelength multiplexing and demultiplexing components before and after the optical amplifiers such that a lower cost single wavelength EDFA would be employed at day 1 for a single wavelength LR-PON. Additional amplifiers could be added when the system was upgraded to WDM capability. A simple implementation of this amplifier node design for the single fibre ODN and two fibre backhaul LR-PON is shown in Figure 19. An additional advantage of this configuration would that amplifiers tailored to specific requirements could be added as required (for example amplifiers for higher capacity core wavelengths or flexgrid channels and higher bit-rate LR-PON such as the 40Gb/s system discussed previously). This also enables costs to be fairly

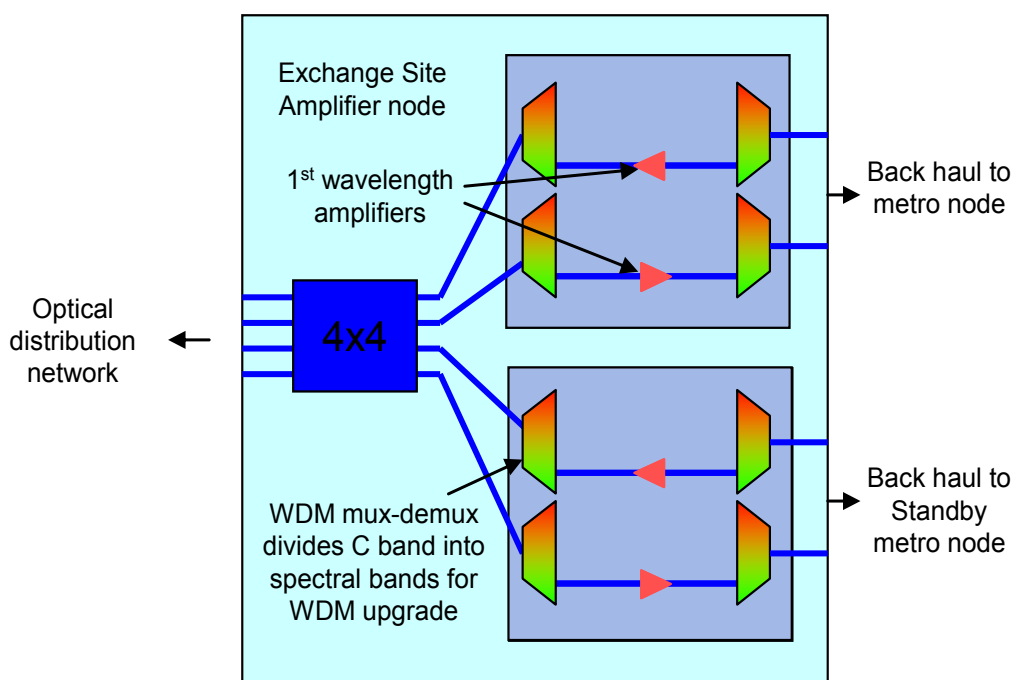

Figure 19 Amplifier node with WDM devices to separate amplifier functions and facilitate lower start-up costs

apportioned to the services carried by those higher capacity channels while enabling the basic wide scale deployment of the basic 10Gb/s LR-PON to be kept as low as possible.

The simple WDM solution shown in Figure 19 can be implemented as an upgrade in the same way the amplifiers could be upgraded later in the options shown in Figure 16 to **Error! Reference source not found.**; the WDM components do not need to be installed at day one. However this solution does have some cost and design issues; one problem is the additional cost of the WDM mux/demux devices, a second is the additional optical loss associated with these components. The fixed WDM components will also require an agreed and standardised wavelength plan for the access network to be in place when they are installed and may limit flexibility in wavelength usage if future changes from that wavelength plan are required.

It should be noted that when WDM is implemented on the LR-PON a WDM device also needs to be placed before the OLTs in the working and standby metro nodes, if these were not pre-installed. These WDM devices in the metro-core node are optional for an initial single wavelength installation and may be omitted at day one but again power budget and OSNR design of the LR-PON must take into account the subsequent upgrade to WDM provisioning.

2.7.5 Additional optical amplifier design considerations

An important issue in burst networks using EDFAs such as long-reach TDMA PONs are the power variations at the input of the EDFAs which could cause large output power transients. These transients need to be added to the upstream dynamic range, and if they are very severe they could possibly prevent the error free reception of the upstream signal [5]. Commercial EDFAs are available with pump control to suppress gain transient due to adding and dropping of channels in reconfigurable core and metro nodes. We believe that these types of commercial EDFAs could provide suitable gain transient suppression also for the long reach PON architectures analysed in DISCUS. The performance of these commercial EDFAs will be evaluated in task 5.1. The use of external clamping wavelengths and control circuits may also be investigated if necessary to improve the gain transient performance.

2.8 Candidate modulation techniques for core bandwidth over LR-PON infrastructure

This section provides a review of possible solutions for core bandwidth transmission over the LR-PON infrastructure and gives a brief outline of the candidate transmission technologies and techniques that will be explored in DISCUS. The detailed analyses of the possible physical layer transmission technologies that can be employed over the LR-PON architecture will be studied and described in detail in WP4.

Besides OOK transmission other transmission technologies will be investigated in DISCUS from both technical and economic perspectives as possible future upgrades and options for core bandwidth transmission over the LR-PON. Three main transmission technologies will be considered: (a) dual-polarization quaternary phase-shift keying (DP-QPSK) [6], (b) orthogonal frequency-division multiplexing (OFDM) [7] and (c) Nyquist-WDM [9].

2.8.1 Options for core wavelength Transmission over LR-PON - DP-QPSK

Dual-polarization quaternary phase-shift keying with digital coherent reception has been shown to be able to transport 40 Gb/s over legacy 10 Gb/s links as it has the same tolerance to OSNR and higher tolerance to chromatic dispersion (CD) and polarization mode dispersion (PMD) [6]. Commercial solutions exist that can also carry 100 Gb/s over legacy 10 Gb/s links [6]. By using the capabilities allowed by the DSPs in the digital coherent receiver (CD and PMD compensation, strong forward-error-correction ([FEC]) etc.) it should be possible to deploy a 100 Gb/s channel on the same LR-PON designed for 10 Gb/s NRZ links. Further study will be carried out as part of task 8.3, including possible cross-talk effects from the bursty traffic of the 10 Gb/s PON upstream links on the 100 Gb/s channel and vice-versa.

2.8.2 Options for core wavelength Transmission over LR-PON – CO-OFDM

Orthogonal frequency-division multiplexing can be used for transmission capacities of up to 100 Gb/s per wavelength by employing high modulation format order such as 32- up to 128- quadrature amplitude modulation (QAM). In addition, advanced modulation techniques can be adopted such as adaptive loading algorithms (ALAs) on OFDM subcarriers [8] plots the bandwidth against the QAM levels used, for data rates of 10, 40 and 100 Gb/s. It is revealed that there is an inverse exponential reduction of the bandwidth required as the number of QAM levels increases. Regarding the transmitter side, the two main options are intensity and field modulation. In the former (which implies lower cost and complexity) the subcarriers are created and processed in the RF domain, the resulting signal modulates the optical intensity to produce the optical signal to be transmitted.

Field modulation, on the other hand, requires the use of IQ modulators (either in the RF domain – followed by up-conversion, or directly in the optical domain). The receiver side can perform either direct-detection or coherent reception. In the former case an optical carrier needs to be transmitted, reducing receiver

sensitivity and spectral efficiency (due to the gap needed between the optical carrier and signal band). However it leads to simpler and lower-cost receivers, because there is no need of a local oscillator (LO) or polarization controllers,

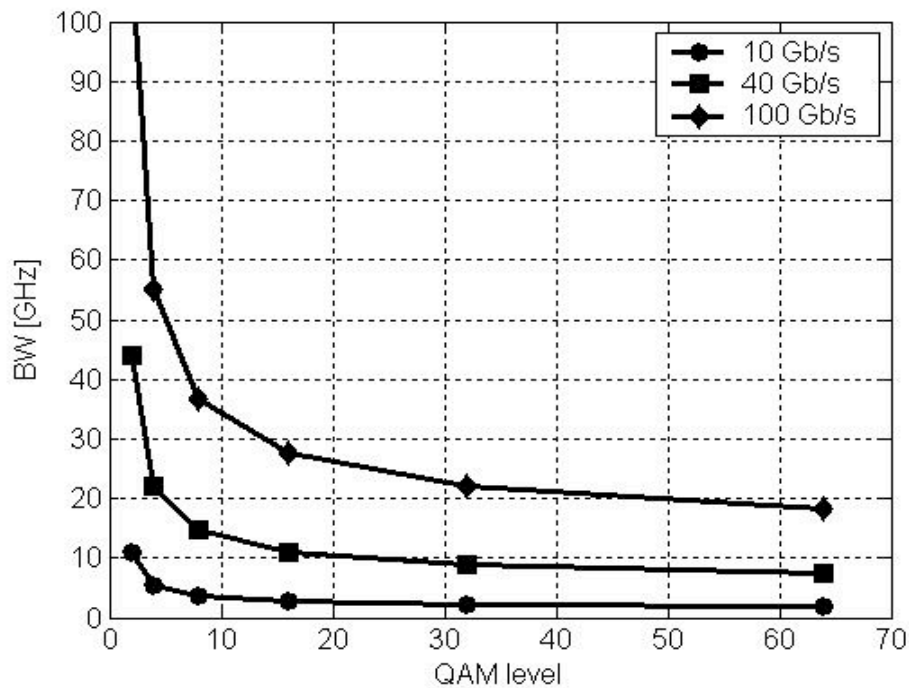

Figure 20 Bandwidth vs. QAM levels for 10 Gb/s, 40 Gb/s, and 100 Gb/s.

which is the case for a coherent receiver. However, the latter provides increased spectral efficiency and receiver sensitivity and also higher tolerance to PMD and CD.

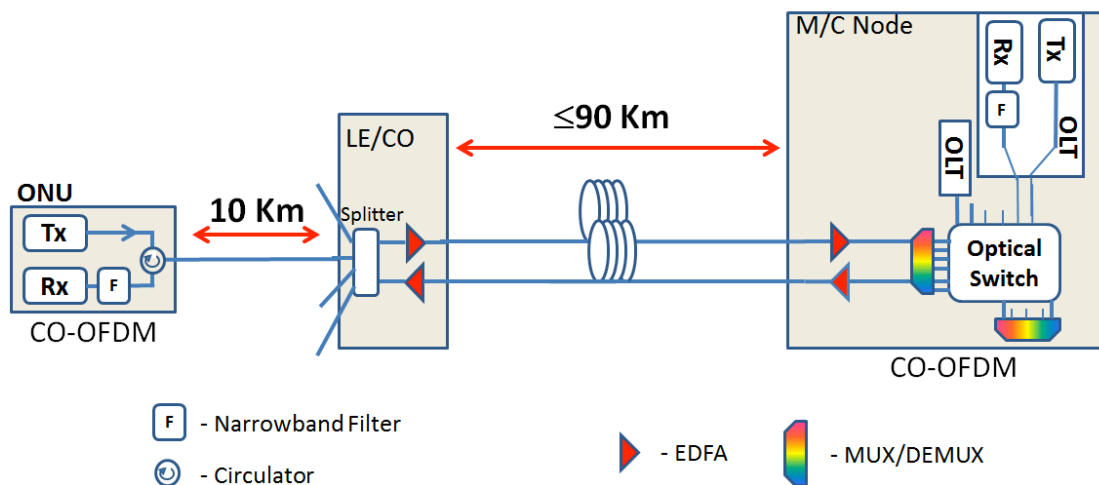

Figure 21 DISCUS configuration for dense urban scenario using a single CO-OFDM channel at 100 Gb/s for both downstream and upstream

An example of OFDM technology for 100 Gb/s single-wavelength for both downstream and upstream transport as implemented in a DISCUS reference

architecture for dense urban scenario is depicted in **Error! Reference source not found.**

2.8.3 Options for core wavelength Transmission over LR-PON – “Flex-grid” & Nyquist-WDM

With the rapid growth of emerging data-centric services, 400 Gb/s or even 1 Tb/s per channel tends to be the next targeted data rate for long-haul optical transmission. However implementing the fast Fourier transform (FFT)-based OFDM processing at such high data rates is restricted by the operation speed and expense of the electronic circuits required, such as digital-to-analogue/analogue-to-digital converters (DACs/ADCs.) [nn5].

Therefore in DISCUS we will also investigate Nyquist-WDM with coherent detection for core transport over the LR-PON infrastructure and also elastic optical networks (EONs) in which a flexible spectrum grid (“flex-grid”) is enabled. An EON solution will also allow compatibility with emerging solutions for core transport.

2.8.3.2 Comparisons of CO-OFDM, CoWDM, and Nyquist-WDM

In **Error! Reference source not found.**, we show the spectrum of three different transmission solutions and compare them: CO-OFDM, a traditional coherent-WDM (CoWDM), and Nyquist-WDM. In **Error! Reference source not found.**, (a), each modulator generates many low bandwidth (Δf) subcarriers to form each band. Orthogonality is maintained between bands by ensuring a spacing of $\Delta f_G = m \times \Delta f$ between the outside subcarriers of adjacent bands for

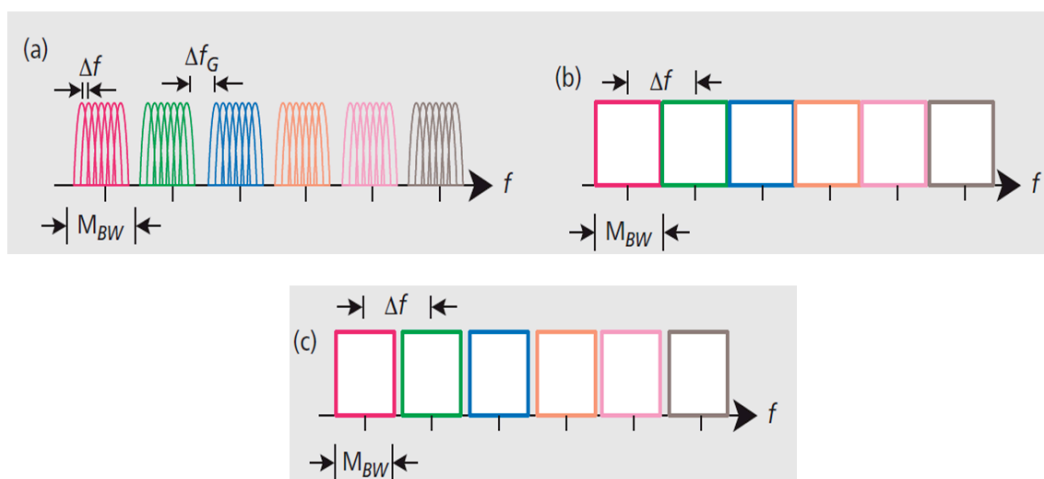

Figure 22 Comparison between CO-OFDM, CoWDM, and Nyquist-WDM: a) CO-OFDM generates many low-speed subcarriers using an inverse fast Fourier transform (IFFT) to ensure orthogonality; b) CoWDM operates by combining many orthogonal subcarriers together to form a seemingly random waveform; c) Nyquist-WDM combines many independently generated channels together with a minimum guard band. The tick marks indicate locations of modulated comb lines. Δf : subcarrier frequency spacing; Δf_G : frequency spacing between CO-OFDM bands; MBW: modulator bandwidth.

integer values of m .

Error! Reference source not found. (b) shows a CoWDM spectrum that consists of several subcarriers. To maintain orthogonality between subcarriers, the CoWDM subcarrier symbol rate is set equal to the subcarrier frequency spacing. This restricts each modulator to generating only an integer number of subcarriers.

Nyquist-WDM Figure 22 (c) attempts to minimize the spectral utilization of each channel and reduce the spectral guard bands required between WDM channels generated from independent lasers. Using aggressive optical pre-filtering with spectral shape approaching that of a Nyquist filter with a square spectrum, the channel BW is minimized to a value equal to the channel baud rate.

2.8.4 Challenges for Core transmission over LR-PON

Multilevel modulation formats require higher OSNR, which may significantly reduce the maximum achievable transmission distance due to the nonlinear impairments [11]. Nonlinearities appear to be even more dominant in OFDM due to the high peak-to-average power ratio (PAPR) [12]. The PAPR problem arises from the fact that the sinusoidal signals from many OFDM subcarriers can occasionally constructively add in the time domain, producing sharp amplitude peaks that are significantly higher than the average amplitude value of the signal. This can put a large strain on RF amplifiers, such that either costly devices and/or a power back-off become necessary to ensure linear operation. In addition, it should be added that OFDM has two other drawbacks: the sensitivity to time/frequency synchronization errors and the phase noise. To improve the tolerance to nonlinearities two DSP techniques have been proposed: The aforementioned ALAs [8][nn4] and a reduced complexity Volterra-based nonlinear equalizer [11], [13]. In addition, the ALAs can be used for reducing the PAPR in OFDM. Finally, for the laser phase noise problem with linewidth ranging usually from 100 KHz to several megahertz, and which needs to be tracked on a symbol-by-symbol basis. this can be treated through phase estimation and compensation using pilot subcarriers as shown in [14].

2.9 OLT configuration options

The LR-PON is terminated in the metro-core node on an optical line termination device (OLT). The term OLT is often used in the industry to describe a shelf of equipment that contains the actual PON optical termination (usually a number of terminations per card) plus a small layer 2 switch and network interface cards to the metro-core node switches and routers. OLT cards can also be designed for insertion into the Multi-Service Access Node (MSAN) in the local exchange or central office. In this section we use the term OLT to refer to the LR-PON optical termination which will have upstream burst mode receiver, downstream tunable transmitter and chipset for the LR-PON protocol. It is envisaged that a termination card containing one or more of the OLTs will be a line card of the layer 2 switch.

The key common features of the OLT are:

- Provide the burst-mode optical receiver capable of receiving and processing the upstream optical bursts which are not phase aligned and will arrive at varying power levels from different ONUs.
- Burst mode electronic dispersion compensation (EDC) which needs to be adapted to each ONU bursts as they arrive at the OLT.
- Burst mode FEC. The FEC must work on the smallest ONU burst and also not include the ONU burst preamble.
- Downstream tuneable optical transmitter covering the C-band.
- A LR-PON TDMA protocol that provides ONU registration and authentication, Ranging, dynamic bandwidth assignment (DBA), Dynamic wavelength assignment (DWA), and Operation Administration and Management (OAM) features etc..

Optional feature dependent on the configuration are:

- Tuneable filter for wavelength selection capability (this will not generally be required)
- Diplexer function to separate/combine upstream and downstream paths from the optical network and the OLT optical transmitter and receiver.

The actual configuration and optical layer functionality of the OLT will depend on the configuration of the metro-core node termination layout. There are a number of options for these configurations that will be compared in detail via functional and economic comparison as part of the DISCUS design process. The main options are shown **Error! Reference source not found.** and **Error! Reference source not found.**

- **Error! Reference source not found.** shows the configuration if the optical switch in the metro-core node is not included in the LR-PON optical path while figure 25 shows the main options when the optical switch is included.
- **Error! Reference source not found.** (a) shows a configuration of two fibre working in the LR-PON backhaul with single wavelength working. It assumes

WDM will be added as a later upgrade. The optical configuration of the OLT therefore is the burst-mode receiver, the tuneable transmitter connected directly to the upstream and downstream LR-PON optical fibres. **Error! Reference source not found.** (a) shows a tuneable optical filter in the OLT receiver path. It is debatable whether this filter is needed and will probably be omitted in the final design. It is not needed for a single wavelength system and is only present in case any other wavelengths are operating over the LR-PON fibre prior to WDM LR-PON upgrade. When WDM upgrade is added later a WDM device will be inserted into the fibre path before the OLT receiver and transmitter and this will provide the wavelength selection function obviating the need for a tuneable filter.

- **Error! Reference source not found.** (b) shows the same configuration but with single fibre working in the LR-PON backhaul, A circulator is now added to the OLT to provide the separation of the two transmission directions and connection to the OLT receiver and transmitter. The same arguments concerning the need for the tuneable filter as in option (a) also apply to option (b). Figure 24 (b) has the most complex OLT optical configuration.
- **Error! Reference source not found.** (c) shows two fibre backhaul but now with WDM upgrade and therefore WDM devices placed into the upstream and downstream fibre paths. The optical filter is not now required and is omitted. The OLT optical configuration is now simply the optical burst-mode receiver and tuneable transmitter no optical diplexer is required. Not the two fibre working uses two WDM devices which although more costly enable the full C-band spectrum to be used in both the upstream and downstream directions.
- **Error! Reference source not found.** (d) shows the WDM upgrade options but now with single fibre working in the backhaul of the LR-PON. Only one WDM device is used and this also provides the diplexing function for the OLT. However

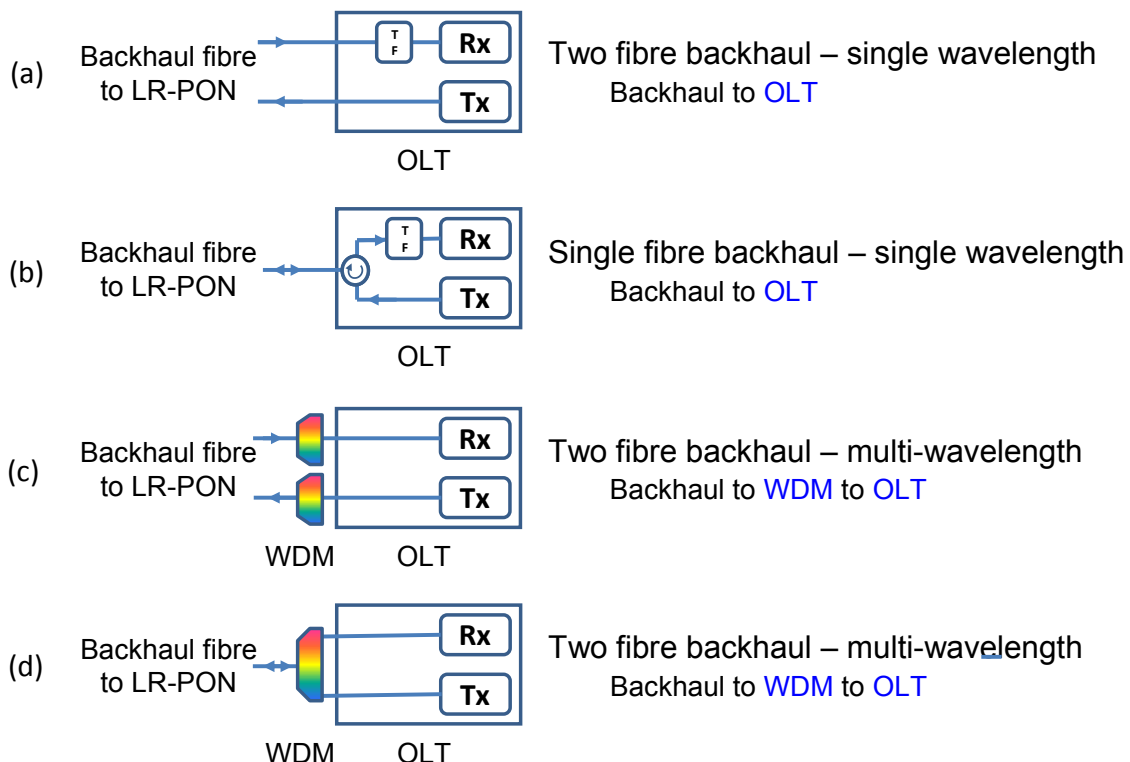

Figure 23 OLT configuration options without optical switch

the optical spectrum now needs to be shared across the upstream and down stream directions which halves the available spectrum for future traffic a services.

The above options do not include the optical switch in the LR-PON fibre paths. This limits flexibility and also requires 1+1 sparing for protection. In DISCUS it is proposed that an optical layer using an optical space switch is inserted between the optical fibres and wavelength channels of the access and core optical fibres and the electronic layers of the metro-core node. **Error! Reference source not found.** shows the main options for the OLT configuration when the optical switch layer is included. The options shown are for the WDM upgrade case, but of course the switch could also be added to the single wavelength options of

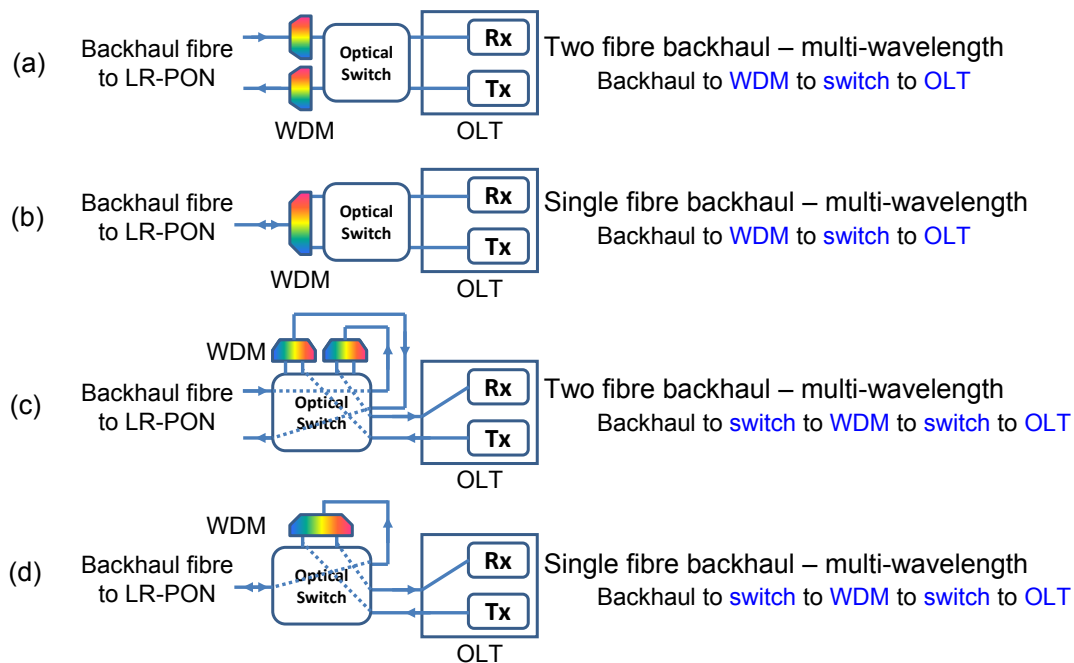

Figure 24 OLT configuration options with optical switch

Error! Reference source not found..

- **Error! Reference source not found.** (a) shows two fibre working with the WDM devices connected directly to the upstream and downstream LR-PON fibres. The wavelength ports of the WDM devices are then connected to the optical switch and then to the simple OLT s. This option allows flexibility in assignment of LR-PON wavelengths to different OLTs and other functions such as core wavelengths transported over the access LR-PON network. It also enables 1+N OLT sparing to be used for protection strategies however the WDM devices need to be provided on a 1+1 protection strategy.
- **Error! Reference source not found.** (b) shows the same basic options as **Error! Reference source not found.** (a) but with single fibre working in the LR-PON backhaul.
- **Error! Reference source not found.** (c) shows the most flexible configuration with the LR-PON fibres connected directly to the optical switch which are then switched to the WDM devices and then the single wavelength ports of the WDM

devices switched to the OLTs. This allows full flexibility of the assignment of access fibre to metro-node functions, it also allows 1+N sparing for protection strategies to apply to both WDM devices and OLTs.

- **Error! Reference source not found.** (d) is the same configuration as **Error! Reference source not found.** (c) but with single fibre working in the LR-PON backhaul this has the advantage of using by directional working through the optical switch saving switch ports but like all single fibre solution it halves the available optical spectrum for future traffic and service provision. Options (c) & (d) require two traverses of the optical switch in the LR-PON backhaul fibre path this will increase optical loss. The impact of the increased optical loss will depend on the placement of the optical pre-amplifier (which has not been shown in the **Error! Reference source not found.** and **Error! Reference source not found.** options). The impact of this loss and amplifier placement will however be taken into account during the DISCUS design activities.

These options have fairly subtle trade offs of various cost elements and will require careful analysis using the economic models and also the evolution scenarios that will be examined as part of the DISCUS project.

2.10 Bespoke networks solution over LR-PON infrastructure

In addition to resiliency, there are also other drivers for adding network side splitter ports, for example to provide cross links between different parts of the LR-PON or adjacent LR-PONs. Typical uses could range from providing bespoke network capabilities for specific users or providing alternative, shorter routes (i.e. bypassing the long feeder fibre) for interconnecting ONUs with lower latency (e.g. using the PON as a backhaul for mobile base stations. These options will be studied in more detail within other work packages in DISCUS and will be reported in later deliverables. In this section an outline of bespoke networks solutions will be given assuming the spare ports on the network side of the splitters are provided as part of the initial LR-PON build.

The LR-PON solution is aimed at providing ubiquitous high speed connections to all users on a common network platform. The use of the wavelength domain allows bandwidth to be increased for these users and also allows small sets of users to receive even greater dedicated bandwidths including complete dedicated wavelengths to individual customer premises. This bandwidth capability includes core bandwidths delivered to the edge of the access network. This is the “Principle of Equivalence” of all network connections and will be a realisation of one of the key DISCUS objectives. However it is also recognised that there will be a relatively small number of customers that want different “private” and bespoke network solutions; that is a custom designed network for their operations which could involve alternative connections to the access network infrastructure in addition to the LR-PON systems.

Enabling alternative configurations of the optical access network using both the wavelength domain and physical infrastructure (in this case fibre) configurations also enables ideas about open access and virtual networking and software defined networks to be incorporated within the main DISCUS architecture. The concepts of private circuits (PCs), and virtual local area networks VLANs have been long established in the telecommunication industry and were the fore runner of the modern concepts of virtualisation and software defined networks (SDN). We will define “bespoke” networks as the collective term for the set of private (PCs, VLANs, SDNs) and virtualised networks (VNs) to mean network resource configurations set up and configured for specific customers (or groups of customers) for private networks that are not accessible by the other “public” users of the network.

When considering bespoke networks a distinction needs to be made between those networks where the resources can be set up without physical intervention and network visits (that is engineers needing to visit network locations to reconfigure or add plant, equipment or components) and those that can be configured by network control systems such as management or the control planes. The latter paves a way to virtualisation and software defined networks. The control of the resources (for example customer control or operator control) for the setup and tear down of these SDNs, and the time scale that is required, is a matter of debate. Giving too much control over network resources opens up serious security issues and increased possibility of denial of service attacks by malicious users. These issues are common to all networks and the DISCUS

architecture would not be immune, however the simplification and the use of common control planes may enable greater separation between critical network control plane functions and any user control plane capability.

In this section we look at the physical layer options for bespoke networks over the DISCUS architecture but when implementing a real network higher layer control issues will be a key aspect of the detailed design process.

There are two broad approaches to providing bespoke networks over the DISCUS architecture one is to use the wavelength domain including optical spectrum outside the main C-band where the LR-PON wavelengths will operate. The other is to use spare fibre infrastructure and physically configure these fibre for bespoke network operation. A third option would be a hybrid of the two approaches using both wavelengths and fibre.

2.10.1 Bespoke WDM LR-PON network configuration

An example of a bespoke network using the wavelength domain outside and inside the C-band is shown in Figure 25 This example also uses some infrastructure build to interconnect lower reaches of the LR-PON infrastructure.

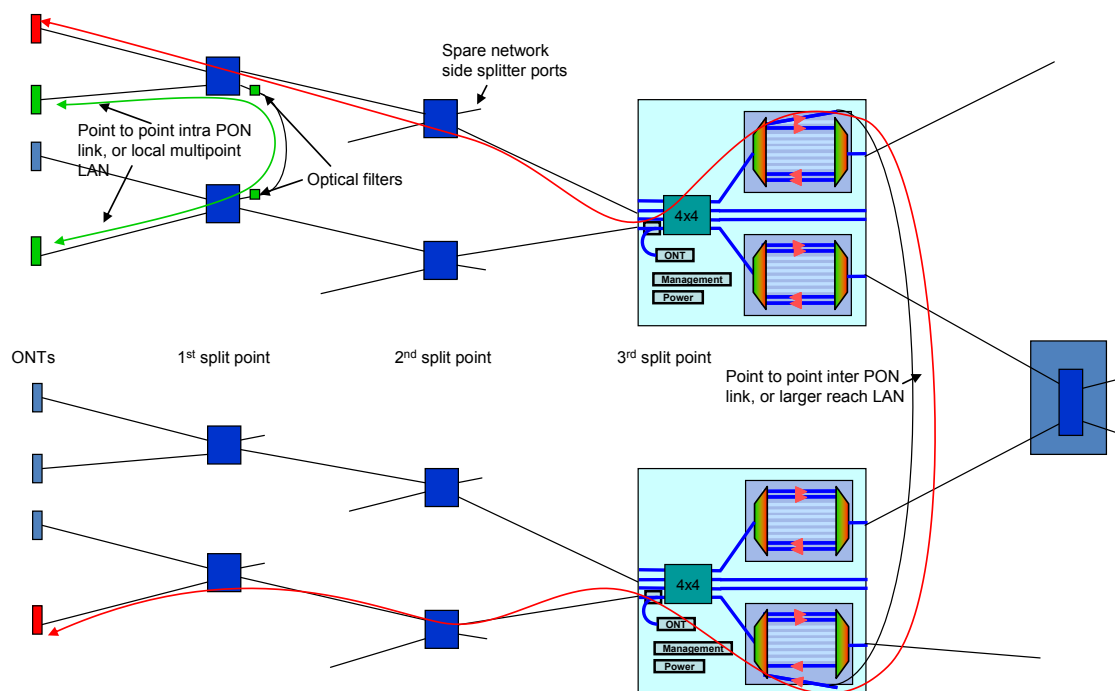

Figure 25 Bespoke WDM LR-PON network configuration examples

The LR-PON needs additional network side optical fibre ports on the splitter stages which mean deploying an MxN splitter design rather than the simpler 1xN used in conventional PONs. It is important to add splitters with these ports at day one rather than adding later. If they are added later there is a $10\log(M)$ dB increase in insertion loss plus excess splitter loss for an M-way splitter. The other serious problem if the MxN is not fitted at day one is that a service interrupt will occur if an in service upgrade is performed this should always be

avoided if at all possible. The cost of an MxN splitter should be quite small with each additional port only costing about 10 Euros.

The number of additional upstream ports needs to be determined by considering the number of customers that might require these services plus any additional use of upstream ports such as diagnostic ports for in field network testing. One application that may require additional upstream ports, and cross link connections, could be small radio base stations, connected to the LR-PON, that need to negotiate spectrum and transmit power parameters on very short time scales. The round trip time (RTT) of the full LR-PON might be too long for the interchange of these base station messages and could be reduced by using fibre cross links interconnecting the splitter stages that are closer to the base station locations. Another application is a high bandwidth local LAN/WAN service for a large business. Other applications can be storage area network server synchronisation etc.

In figure 25 there are two wavelength paths shown, a green path that shows a wavelength traversing two branches of the same LR-PON and a red path that shows a wavelength channel traversing two different LR-PONs at the amplifier node.

In this example the green path requires a fibre to cross link the two LR-PON branches. In **Error! Reference source not found.** this fibre link is shown to connect across at the distribution point splitter closest to the customer. It could also have cross linked at the cabinet splitter. Either location would require some field work to provide the cross link fibre connection; therefore this type of bespoke network is not configurable via SDN or network management systems. Because this wavelength traverses the LR-PON below the amplifier node all the windows of the optical fibre outside the C-band (and possibly the L-band if this is not reserved for wavelengths to and from the metro node) can be used. To limit the spectrum available for any one of these bespoke network wavelengths operating over the ODN of the LR-PON and also to limit crosstalk, an optical band pass filter should be added to the cross link fibre. Whether blocking filters are needed at the amplifier node will depend on the design of the amplifier node if a WDM device is used at the node then blocking filters will not be required, also wavelengths outside the C-band will be blocked by the EDFA amplifiers.

The red path in Figure 25 passes through the LR-PON splitter network and will need amplification before traversing the downstream path. This will probably need to be in the C-band and therefore will need to use potential metro node wavelengths. Wavelength usage options in the DISCUS architecture will be explored in Work Package 3 and will help steer the technical design options of the DISCUS network. If wavelengths used for the bespoke network are in the C-band then there is also the option of traversing these wavelengths up to the metro node and turned around onto another LR-PON (or possibly sent over a core wavelength to another metro-core node).

An advantage of using C-band wavelength up to the metro-node is that there is no network build required and they could be set up via SDN configuration. It should also be noted that wavelengths traversing up and down LR-PONs may be

signal level and OSNR limited and may require regeneration. This would limit transparency for these wavelength channels.

2.10.2 Bespoke network configurations using spare fibre in LR-PON cable

Bespoke networks sharing the same fibre infrastructure as the LR-PONs raises questions about management and control and network security. It will be necessary to ensure that wavelengths from bespoke networks cannot interfere with other wavelength operating over the infrastructure. This might require control and management channels always to be available to the network control and management planes even for private networks that do not reach or traverse the metro-node.

An alternative to using the wavelength domain over the same fibre network as the LR-PON is to use spare fibre. Because in the DISCUS architecture there will always be some spare fibre available and operators always build in spare capacity for future potential growth when installing fibre cables. Some of these spare fibres can be used for bespoke networks. The network configuration shown in **Error! Reference source not found.** are simple configurations that provide point to point connections using spare fibres that are separate from the LR-PON ODN and backhaul fibres.

There are of course a great many possible configurations of bespoke networks and the detailed comparisons will require optical network design models to

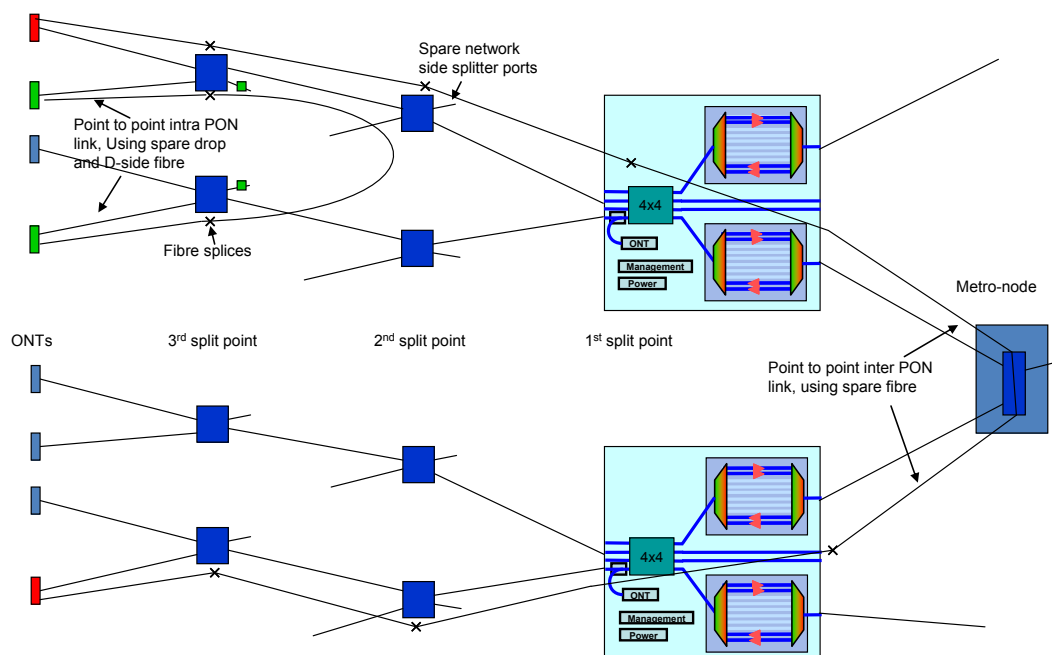

Figure 26 Bespoke networks using spare fibres

determine viable options for different sets of requirements. However all designs must be carried out as part of the overall design of the DISCUS architecture and control and security issues must be considered as part of this design process. Examples of bespoke network designs will be included in the design activities of the DISCUS project.

3 The metro-node core design

The initial metro node design in the DISCUS proposal is shown in Figure 27. The main principles of this architecture for the metro node is to have a transparent optical layer in the form of an optical circuit switch that all other network functions, links and electronic switching/routing layers connect to. The optical layer then allows any layer below the optical switch to grow or shrink independently as the network evolves and traffic grows or shrinks. It also doesn't distinguish between access ports and core connection ports and also enables direct connection to and between optical paths in access and core networks. This is part of the enabling of core capability to the access edge which is one of the major aims of the DISCUS architecture.

Figure 28 shows this optical circuit switch layer with layer 2 and layer 3 routers

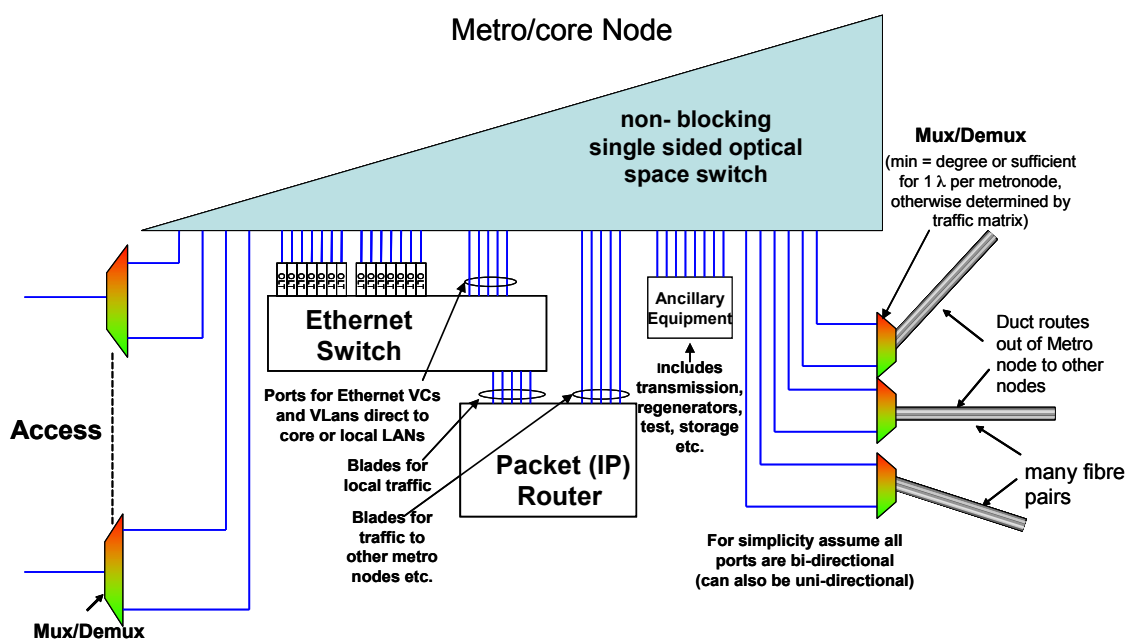

Figure 27 Initial proposal for metro-core node architecture

as and Ethernet layer and IP layer respectively also shown in this figure is a block of functions called ancillary functions these functions could be wavelength conversion, regeneration, test and diagnostics etc.

One of the benefits of the optical switch layer separating the access and core physical layer from the electronic processing layers is that new network protocols and routing and switching system can be tried in parallel with the conventional systems. Even experimental systems could be given limited access to the network. If these new systems prove successful they could gracefully displace old legacy systems. Such flexibility is a key design feature of the DISCUS architecture and is an important component of the evolution capability of the network architecture ensuring it does not itself become a legacy network

The following subsections will describe options and functions of the various layers in the metro-core node architecture.

3.1 The optical switch layer

The simplest switch would consist of a single crossbar matrix as shown in **Error! Reference source not found.** For an $N \times M$ crossbar switch, the number of cross points needed is $N \times M$. Usually switches are square matrices with $N = M$

For a large switch, this simple switch structure becomes very expensive for example a 1000×1000 switch needs 1,000,000 elements. The simple crossbar switch is strictly non-blocking, that is, any unoccupied input port can be switched to any unoccupied output port without any need to re-arrange any

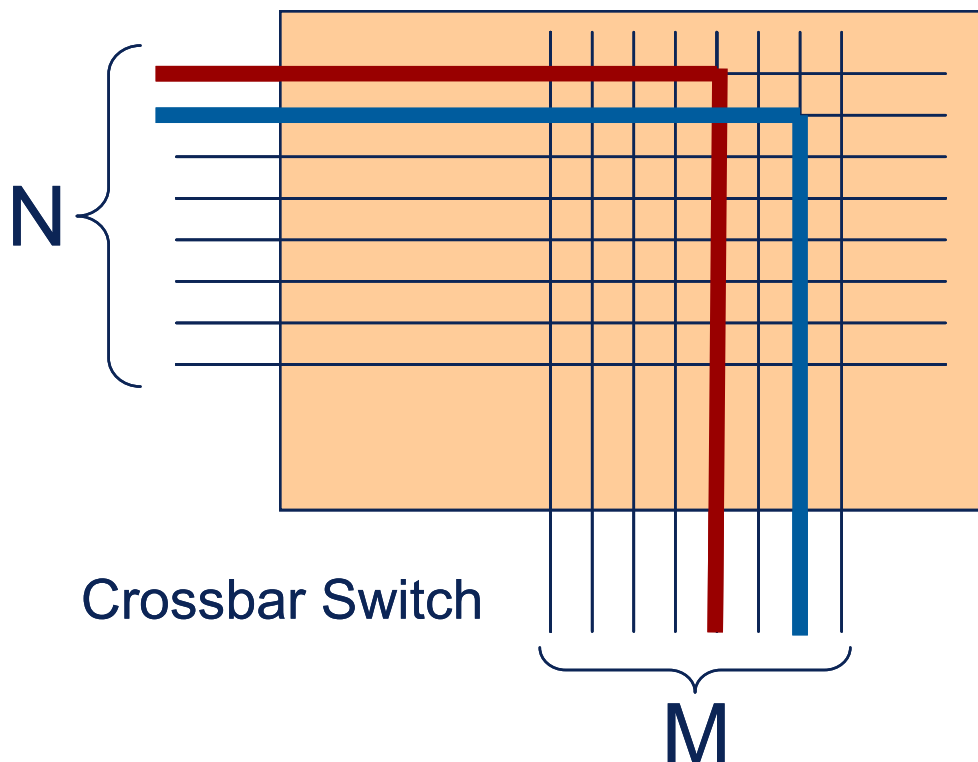

Figure 28 Simple $N \times M$ crossbar switch

existing connections.

In 1953, Clos developed the theory showing that it was possible to develop a multi-stage non-blocking switch with many fewer cross points [15].

A single stage $N \times N$ switch (N input ports and N output ports) requires N^2 cross points. A Clos network as shown in Figure 29 **Error! Reference source not found.** requires only:

$$\text{Clos cross points} = [2nr + nr^2] = 2N(2n+r),$$

using $m \cong 2n$ and $N=nr$

For a 1024×1024 switch:

- A conventional 1024 x 1024 switch requires 1,048,576 cross points
- A Clos network of 16 x 31 and 64 x 64 switches requires 190,464 cross points
- So the Clos network for this example uses 82% less 2x2 cross points.

A basic Clos switch is a three stage structure as shown in **Error! Reference source not found.** By using a multi stage network the number of cross points can be considerable reduced with respect to a cross bar switch the feature of the Clos design is that by having non square input and output stage switches with m

Clos Network

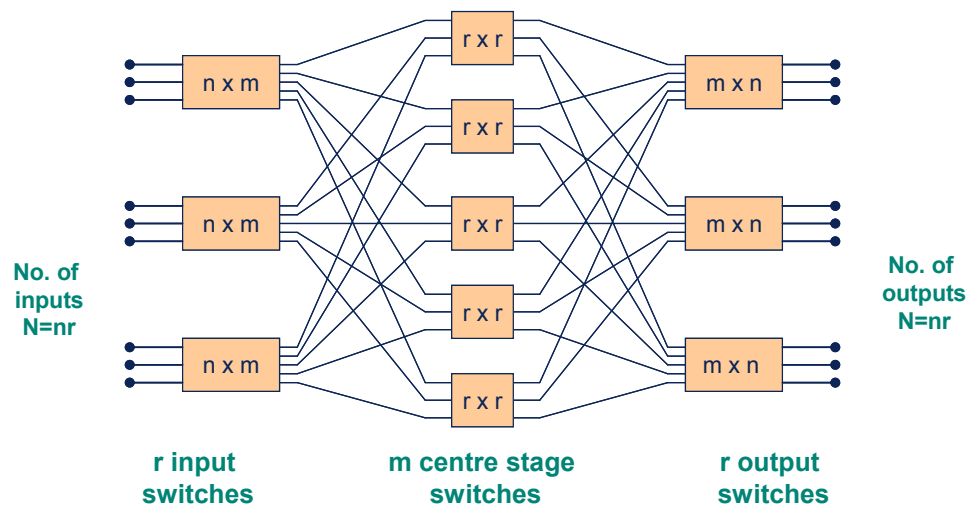

Figure 29 Clos theorem: For strictly non-blocking operation, $m \geq 2n - 1$

$\geq 2n - 1$ then the switch is strictly non blocking the same as the simple crossbar switch.

The structure of the switch shown in **Error! Reference source not found.** is a conventional two sided Clos switch with an input and output side however it is also possible to configure switches that are single sided where a port can be considered to be an input or output and all ports can connect to any other port. In the two sided switch input ports cannot connect to other input ports and output ports cannot connect to other output ports.

3.1.1 Two sided Clos switch using optical beam steering matrices

For DISCUS we are proposing using the Polatis beam steering switches, these are built from ultra low-loss beam steering elements that provide a 3-D switching matrix requiring only $2N$ beam steering elements for a $N \times N$ switch compared to N^2 switching elements for the simple crossbar switch. Current versions of the Polatis switch can provide up to a 192×192 switch matrix. To build larger switches these can be configured into a 3 stage Clos network as shown in Figure 30.

The low loss of the Polatis switch is a critical parameter in a flat core network design. Through traffic transiting the metro core nodes will need to traverse the optical switch and minimising loss will help to extend the reach of the optical island. Also the low loss may also enable the input fibres from core and access to directly connect to the switch and enable full flexibility between fibre and network equipment functionality. The loss of the Polatis switch stages is typically about 1dB or less so even a three stage Clos switch should have a loss of only ~ 3 dB.

The configuration in Figure 30 shows a 2 sided Clos switch using Beam steering matrices. Two sided switch structures are the conventional design of Clos switch architectures. The maximum size of a two sided switch using 3-D Beam steering switch matrices will be dependent on the maximum number of ports that a single beam steering element can scan. With the current switch technology this is 192 ports. The maximum size N of the switch is:

$$N = r(m+1)/2$$

For the maximum size with current technology $r=192$ and $m=191$

Therefore $N = 192(191+1)/2 = 18,432$ ports (note in this report N the number of input ports is used to define the size of the switch rather than $2N$ the total number of ports; N is later used as a comparison of switch sizes)

The number of beam steering elements N_{BT} is given by :

$$N_{BT} = 10N - 4N/n$$

For the maximum size switch above $n = (m+1)/2 = 192/2 = 96$ (rounded down to the nearest integer number).

This gives a value for the total beam steering elements required $N_{BT} = 184,320 - 4 \times 18,432 / 96 = 183,552$ elements.

This compares to $18,432^2 = 340$ million cross points for a cross bar switch of the same size. A full Clos switch of the same size but using cross bar switches would require 7.1 million cross points. It can be seen therefore that in terms of total switching elements the beam steering technology is very efficient.

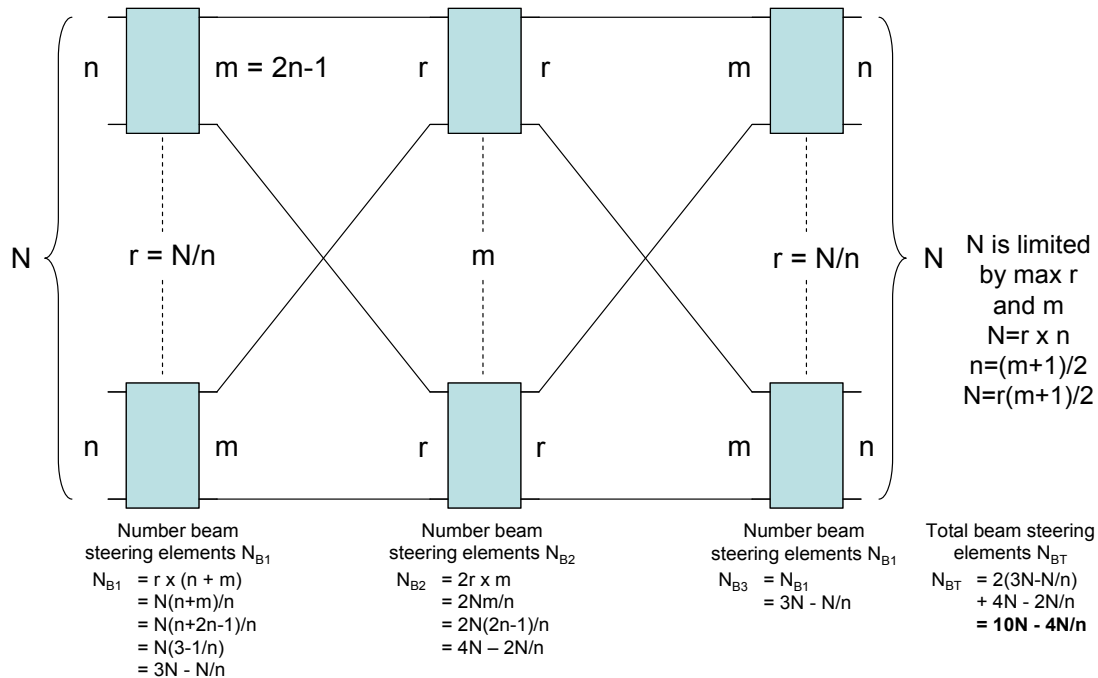

Figure 30 Two sided Clos switch using beam steering switches

It should be noted that a Clos switch can be made more efficient than the example above by using more stages than three, effectively each switch matrix in the Clos network is itself a Clos switch this is repeated until the matrix size reaches an optimum value which works out to be the transcendental number e . Of course a real switch matrix cannot have non-integer numbers of ports so the optimum size matrices with the closest integers to e are 2×3 and 3×3 switch matrices. These 2×3 and 3×3 matrices would be built into a recursive series of multistage Clos switches to build switches of the required size. However even optimised Clos switches using cross bar matrices cannot compete with Clos switches using large beam steering matrices.

Depending on the detailed design of the metro node and the distribution of functions across the switch this number of ports should be capable of supporting metro nodes serving a catchment of $\sim 700,000$ customer sites. To get larger switches the beam steering switch size would need to be increased or the centre stage itself would need to be a three stage Clos network of beam steering switches. This approach however should be avoided as total insertion loss would be increased by a further 2 to 3 dB, it would also use more beam steering elements compared to increasing the beam steering switch size.

In the two sided switch design shown in Figure 30 there is a separation of input ports and output ports into two distinct sets and for a connection through the switch a port from each of these sets must be selected.

3.1.2 Single sided Clos switch using optical beam steering matrices

An alternative configuration is the single-sided switch that doesn't require grouping of ports into input or output. In single-sided switches, any two ports can be connected together and either port can be defined as input or output. There are two configurations for a full strictly non-blocking switch the first configuration is shown in **Error! Reference source not found.** In this configuration the first stage switches are the usual two sided switches but the second stage switches are single sided switches such that any input to one of these switches can be connected to any other port of that switch. Therefore any port from the 1st stage switch to the second stage switch can be returned to any port on the "m" port side of the 1st stage switches and therefore to any input port of the whole switch. In this way any 1st stage switch input/output port can be switched to any other port thus enabling a full single sided switch.

The advantage of single sided switch structures is that planning rules are very simple; any port can be used for any function and it does not matter if it is an input port or an output port. The disadvantage of the single sided switch is that for a given basic beam steering switch size the total Clos network is smaller than the two sided switch network. For the example values used in the two sided switch of Figure 30, $r = 192$, $m = 192$ and $n = 96$. For the single sided Clos network shown in Figure 31 **Error! Reference source not found.** the maximum size switch N is given by:

$$N = r(m+1)/4 = 192(191+1)/4 = 9216 \text{ ports}$$

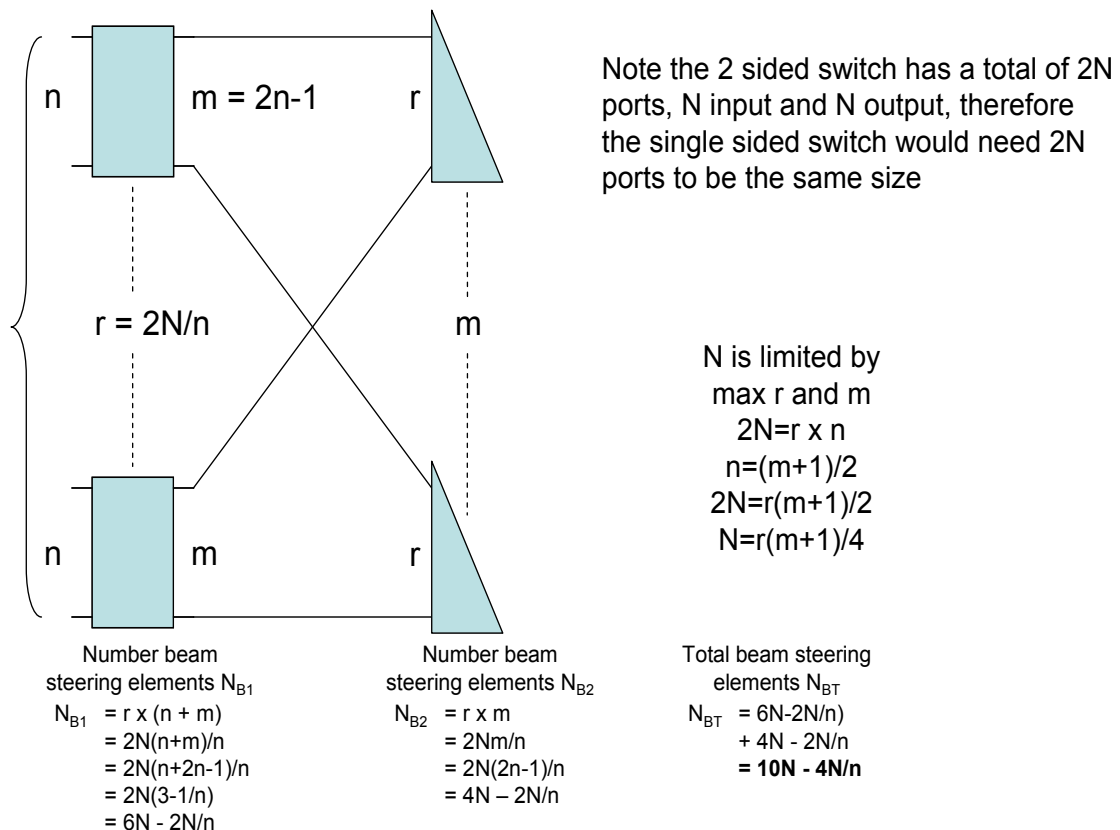

Figure 31 Single sided clos switch network using single sided beam steering switches in the 2nd stage

This is half the size of the two sided Clos switch using the same beam steering capability shown in Figure 30.

Error! Reference source not found. shows another option for a strictly non blocking single sided Clos switch. This configuration uses single sided switches for both the first and second stage switches and has the advantage that any pair of ports on a particular 1st stage matrix can connect together without needing to pass through the centre stages. This can reduce path loss for limited sets of connections. For example input fibre (core or access) could connect via the first stage to optical wavelength mux/demux equipment (either gridded or flex grid) at very low loss (typically <1dB) increasing the overall flexibility of the system and enabling easier upgrade and expansion in the future.

The disadvantage of this configuration is a further reduction in maximum switch size for a given beam steering basic switch size. For this switch the total switch size N is:

$$N = r(p+1)/6$$

Where $p = n+m$

Again p is the maximum size of the 1st stage switches and r = the maximum size of the 2nd stage switches. Therefore for the technology used in Figure 30 and Figure 31 $r=192$ and $p=192$.

Therefore $N = 192(192+1)/6 = 6167$.ports

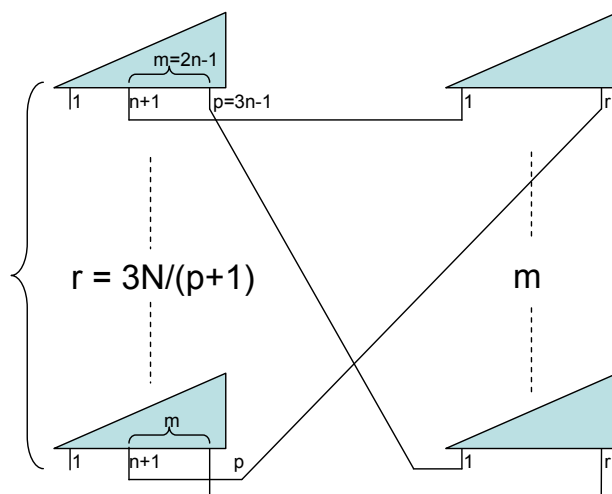

$$\begin{aligned}
 p &= n+m \\
 &= n+2n-1 \\
 &= 3n-1 \\
 \therefore n &= (p+1)/3 \\
 r &= 2N/n \\
 &= 6N/(p+1)
 \end{aligned}
 \qquad
 \begin{aligned}
 2N &= r \times n \\
 &= r(p+1)/3 \\
 \therefore N &= r(p+1)/6
 \end{aligned}$$

Note the first stage switch does not need to be single sided but if it is single sided it may have operational advantages for a partitioned switch where only a portion of input/output ports need to be fully connected via the full Clos switch structure. However this structure has the disadvantage of a smaller total switch size for a given maximum matrix size (limited by technology).

Number beam steering elements N_{B1}

$$\begin{aligned}
 N_{B1} &= r \times p \\
 &= 6Np/(p+1) \\
 &= 6N(3n-1)/3n \\
 &= 2N(3-1/n) \\
 &= 6N - 2N/n
 \end{aligned}$$

Number beam steering elements N_{B2}

$$\begin{aligned}
 N_{B2} &= r \times m \\
 &= 2Nm/n \\
 &= 2N(2n-1)/n \\
 &= 4N - 2N/n
 \end{aligned}$$

Total beam steering elements N_{BT}

$$\begin{aligned}
 N_{BT} &= 6N - 2N/n \\
 &\quad + 4N - 2N/n \\
 &= 10N - 4N/n
 \end{aligned}$$

Figure 32 Alternative single sided Clos switch structure using single sided beam steering switches in all stages

This is a further reduction compared to the two sided Clos network and the single sided configuration with only the second stage employing single sided switches.

Despite the reduction in switch size, the advantage of this approach is in reducing loss of some connections combined with not needing careful planning of switch loading of the node technology and functions. This means that it should be considered as a potential option for the DISCUS node particularly if larger beam steering switches become available in the future.

3.1.3 Partitioned Single sided Clos switch using optical beam steering matrices

The use of single sided switches for the first stage also provides a way of partitioning the switch so that only a portion of the input output ports connect through to the second stage switches. This can reduce the total number of beam steering switch elements required albeit at the cost of adding blocking which reduces full flexibility between all the switch ports. This partitioned switch structure will be described below.

The ability to partition the switch shown in **Error! Reference source not found.**, as briefly described above, may offer a way of reducing the cost of a fully equipped Clos network. If groups of input ports do not need to connect to any other port then a level of partitioning may be possible. In a practical metro node designs it is quite likely that not all input ports will need to be able to connect to any other port. For example, if the access or core fibres are connected directly to the optical switch before connecting to optical multiplexing equipment, then the majority of those fibres do not need to connect to the centre stage switches if the appropriate optical multiplexing devices are also connected to the same 1st stage switch as the relevant access or core fibres.

There will also be other functions that may not need full interconnection, for example not all layer 2 switch ports need to connect to access and core fibre (although some ports will need such connections) similarly for the layer 3 routers. However partitioning of the switch in this way will require more careful planning and distribution of equipment and functions across the appropriate first stage switches and there will be less flexibility for changing configurations without manual interventions and reconfigurations. The trade off is one of operational simplicity and flexibility, which will be difficult to quantify economically, versus the extra cost of providing a high degree of centre stage ports which increase the proportion of full non-blocking connectivity across the optical switch layer.

Such a partitioned switch structure is shown in **Error! Reference source not found.** This switch structure reduces the number of ports that connect to the centre stage switches to a proportion “y” of the total input (or output) ports on the first stage switches, effectively this is a blocking switch with more input/output ports than can be connected via the non-blocking Clos network.

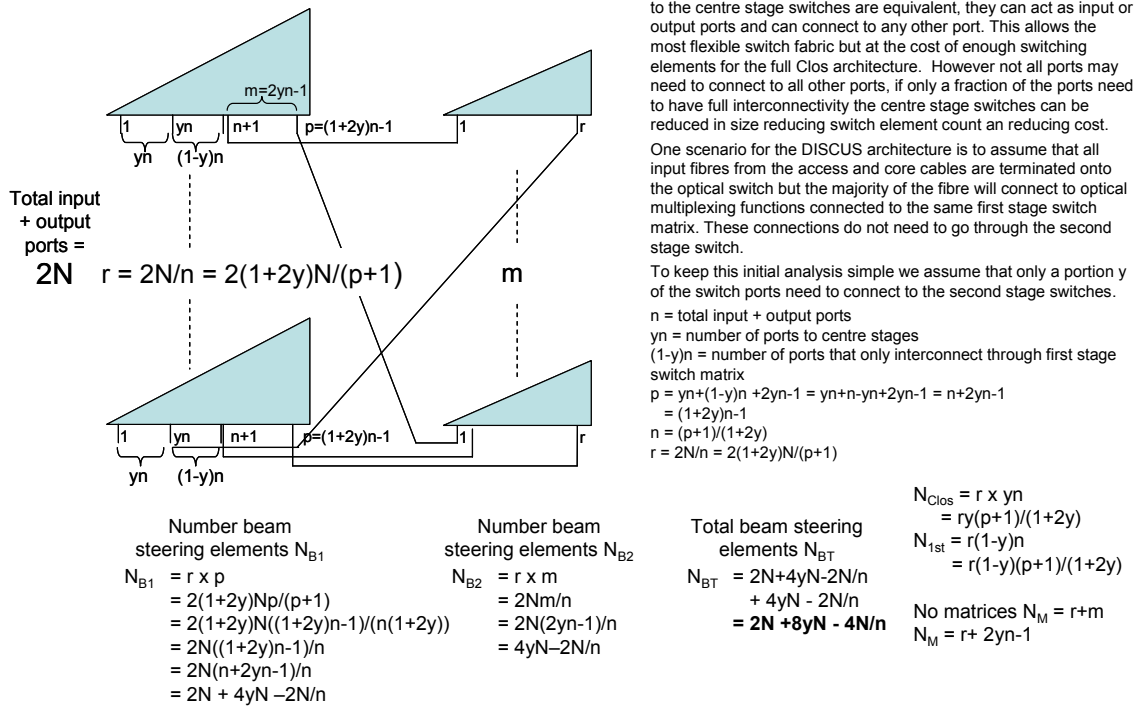

In the full non blocking single sided switch all ports not connected to the centre stage switches are equivalent, they can act as input or output ports and can connect to any other port. This allows the most flexible switch fabric but at the cost of enough switching elements for the full Clos architecture. However not all ports may need to connect to all other ports, if only a fraction of the ports need to have full interconnectivity the centre stage switches can be reduced in size reducing switch element count an reducing cost.

One scenario for the DISCUS architecture is to assume that all input fibres from the access and core cables are terminated onto the optical switch but the majority of the fibre will connect to optical multiplexing functions connected to the same first stage switch matrix. These connections do not need to go through the second stage switch.

To keep this initial analysis simple we assume that only a portion y of the switch ports need to connect to the second stage switches.

n = total input + output ports
 yn = number of ports to centre stages
 $(1-y)n$ = number of ports that only interconnect through first stage switch matrix
 $p = yn + (1-y)n + 2yn - 1 = yn + n - yn + 2yn - 1 = n + 2yn - 1$
 $= (1+2y)n - 1$
 $n = (p+1)/(1+2y)$
 $r = 2N/n = 2(1+2y)N/(p+1)$

Figure 33 Partitioned switch structure trading flexibility for reduced cost.

The maximum size of this switch for a given beam steering switch size is given by:

$$N = (N_{Clos} + N_{1st})/2$$

Where $N_{Clos} = ry(p+1)/(1+2y)$;

the total input plus output ports to the 2nd stage switches

and $N_{1st} = r(1-y)(p+1)/(1+2y)$;

the total ports that can only switch to 1st stage ports

For $r=192$ and $p=192$

the maximum beam steering switch size for current technology:

$$N = r(p+1)/(1+2y) = 192*193/(1+2y)$$

Where $0 \geq y \leq 1$

The relationships are shown in **Error! Reference source not found.** where the proportion of ports to the full Clos network is varied between 0 and 1 where 0 corresponds to zero ports to the Clos network and 1 is 100% of the ports to the Clos network. **Error! Reference source not found.** shows the total switch ports, the number of 1st stage only ports and the number of input ports to the Clos switch as the proportion of ports to the full Clos switch is reduced. Obviously if $y = 1$ then the partitioned switch is the same as the single side configuration shown in **Error! Reference source not found.** with a maximum size of 6176 port size and there are zero first stage only ports and the total ports equals the Clos switch ports.

As y is reduced the size of the full Clos switch reduces while the number of 1st Stage switch ports that can only connect internally within the 1st stage switch increases. The total number of ports available also increases because ports that needed connection to the 2nd stage switch are released for input port use albeit not to the second stage switches. As y approaches zero the number of Clos ports approaches zero and the number of 1st stage ports approaches the number of total ports, this number is 18528 which is the same as the 2 sided Clos switch but without the advantage of being a non blocking Clos switch. When y is zero then there is effectively just a set of independent switches which only requires $2N$

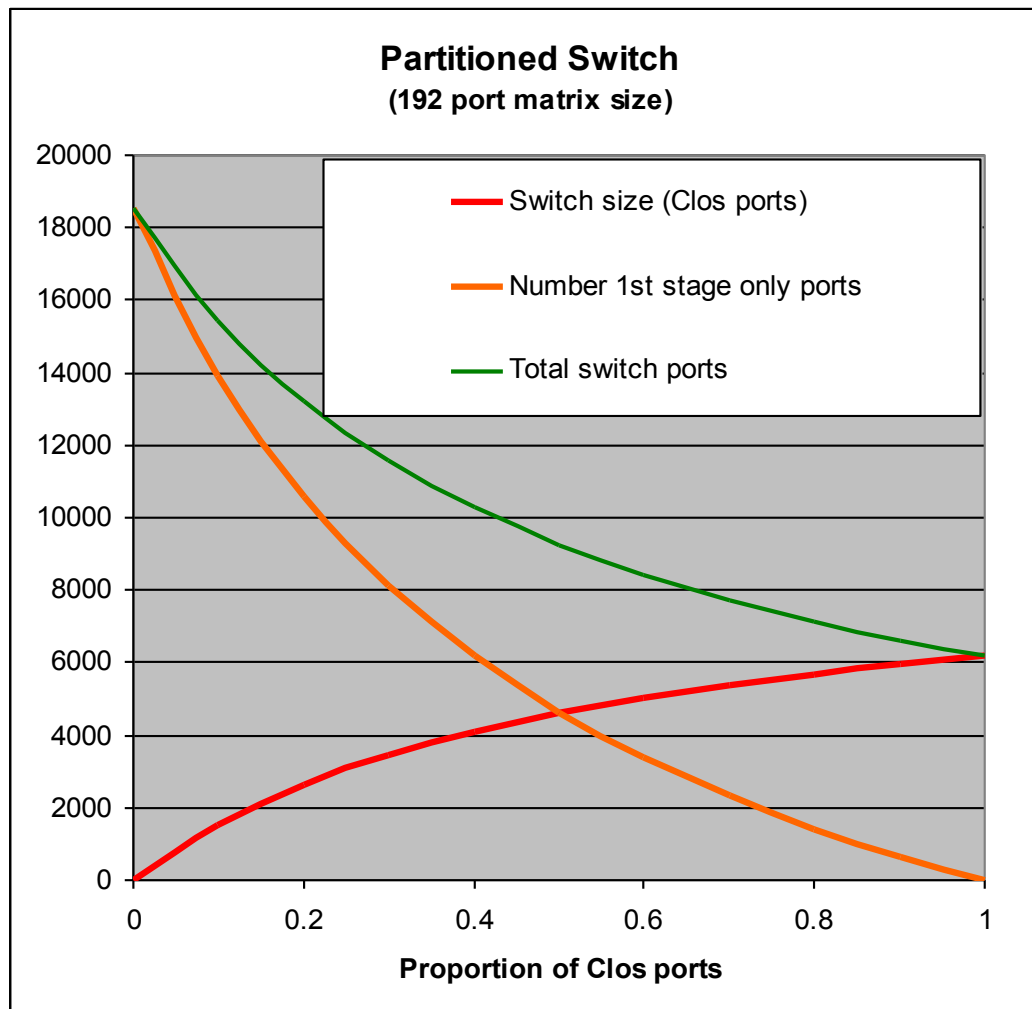

Figure 34 Partitioned switch size v proportion of ports to Clos switch

(37056) beam steering element but with no interconnectivity between the switches.

The DISCUS architecture will require some degree of full non blocking interconnectivity between functions. At this stage of analysis it is unclear what proportion of ports will need full capability. The loss of full flexibility and the requirement for more complex planning rules and working practices and needs to be balanced against the savings in switch costs. The loss of flexibility could include the need for manual reconfiguration of ports as requirements change and different parts of the network grow differently from a growth forecast, this

manual reconfiguration will increase cost but also reduce the ability for SDN and network virtualisation. Another difficulty with the partitioned switch structure is the size of the centre stage switch. This depends on the value of y so it needs to be determined as part of the node design process however once chosen it needs to be fixed and therefore again the switch architecture is less flexible than a full Clos structure.

3.1.4 Growing the optical switch layer

An important design consideration will be how to grow the optical switch as traffic grows and/or the number of customer served by the node grows. The ideal would be to be able to grow the beam steering switch matrix size in situ and the number of switches in the first and second stages (and third stage for two sided switches). However making the individual beam steering switch matrices modular, such that beam steering elements can be added as required, is a major technological challenge and could make the core fabric expensive obviating any growth advantage that could be obtained from smaller incremental growth. For the present analysis therefore we only consider growing the number of switches in the edge or centre stages.

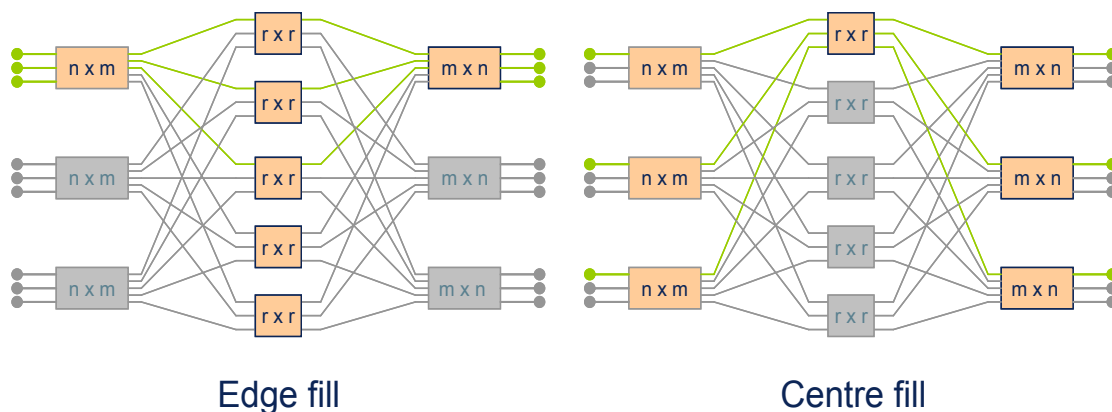

Figure 35 Pay as you grow strategies for a two sided Clos switch using beam steering switches

There are two basic strategies for growing the switches in the stages; either fully populate the centre stages at day one and then grow the edge switches as required or fully populate the edge switches at day one and grow the centre stage switches as required. These we call edge fill and centre fill respectively and are shown in **Error! Reference source not found.** This can provide a reasonable degree of graceful growth on a “pay as you grow” basis. Results of an analysis of the relative costs of the two approaches are shown in **Error! Reference source not found.** It can be seen that both strategies require a fairly high initial investment but the slope of the cost curves show that edge fill is more favourable in early years than centre fill.

PAYG example: 3000x3000 switch

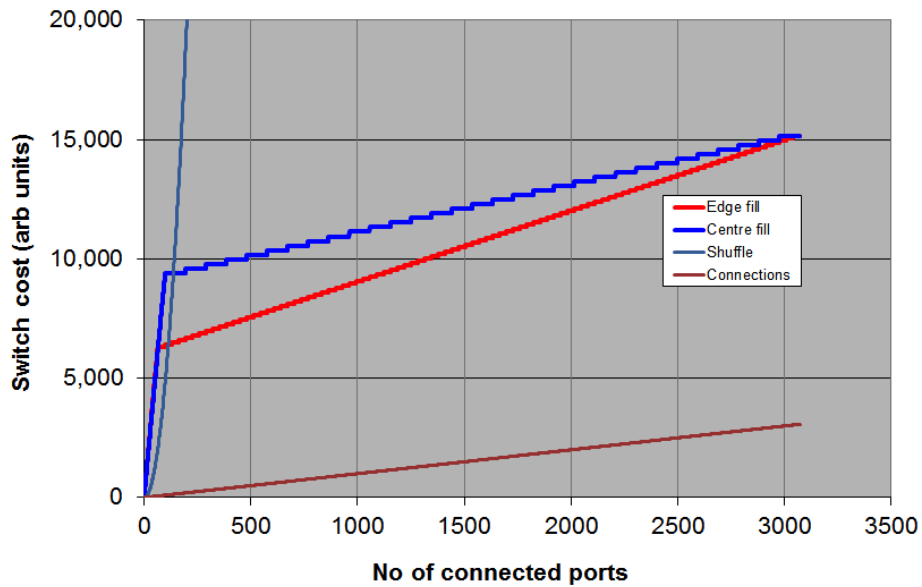

Figure 36 Comparison of edge fill versus centre fill growth strategies

These results are only for two sided switches and will be extended for the other switches structures discussed above later. The results shown in **Error! Reference source not found.** are for a two sided 3-stage non-blocking Clos network using 32x63 and 96x96 elements.

3.2 Alternative metro node structure

Applying the various switch designs for the optical layer and the dimensioning the switch for a range of traffic scenarios and metro node sizes will be examined in more detail as part of the on going DISCUS architecture design process. However to provide an example of alternative metro node structures Figure 37 shows a metro node design utilising a partitioned optical layer switch as shown in **Error! Reference source not found.**Figure 33 but still based on the simple metro node architecture of Figure 27.

In this design the access and core fibres and associated optical WDM components are both connected to and distributed across the 1st stage switches providing flexible interconnect between these functions but also enabling some fibres and wavelength channels to connect directly to other functions connected to the wider switch. Connecting the access LR-PON fibres directly to the switch and then via the switch to the WDM devices can reduce the number of devices required. All the secondary (protection) LR-PONs do not need to have a permanently associated WDM component. A subset of these devices can be provided rather than one for every LR-PON terminated. The minimum number of secondary WDM devices and OLTs required can be determined by the worst case failure that the network is required to protect against. For the DISCUS architecture this will be a single node failure whereby all the LR-PONs that have their primary connection on the failed node will transfer to the nodes with the secondary OLTs. With the LR-PONs connected directly to the switch the standby WDM devices and OLTs can be switched to the appropriate LR-PONs which could be less than a third of the equipment required for full 1+1 protection [16].

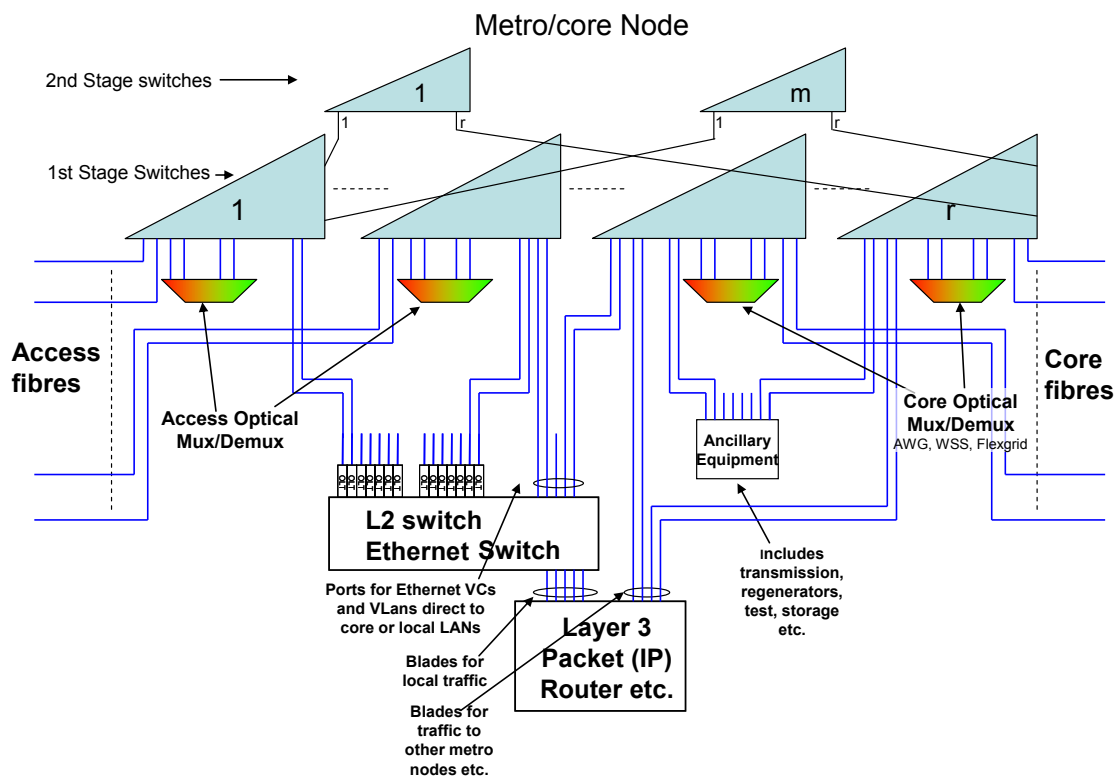

Figure 37 Metro node structure using single sided partitioned switch structure

As previously mentioned, the main issue with this partitioned switch approach is the need for much more detailed planning, dimensioning and distribution of the various functions across the 1st stage switches. This would be needed to ensure adequate local (i.e. 1st stage switch matrix functional connectivity) without the need to connect to other 1st stage switches via the 2nd stage switches

In Figure 37, the access and core fibres and their associated optical WDM components are both connected to the 1st stage switches providing flexible interconnect between these functions. A subset of connection to the second stage switches is also provided, enabling some fibres to connect directly to functions connected to other 1st stage switches, however the partitioning does introduce blocking and not all 1st stage switch ports will be able to connect to other 1st stage switches and functions

3.3 Electronic switch layers interconnect

This section describes options for the electronic layer 2 and layer 3 and other ancillary functions required in the metro-core node. The functional requirements and service support requirements are discussed in Appendices 7.1, 7.2 and 7.3

The electronic switching layer in the DISCUS node architecture provides all the multiple traffic processing functions required in the metro-core node, it will: aggregate and groom user traffic on to the core transmission paths, perform local switching of user traffic and, where the traffic levels do not justify complete wavelength connections across the flat optical core solution it can provide add-drop and traffic aggregation functions for traffic consolidation.

In order to be compatible with current networks, the DISCUS node architecture will consider the current practice of physically separating layer 2 switching from layer 3 routing (often also separating access and core equipment within the same layer). However the design will evolve to consider more integrated solutions, where L2 and L3 data plane switching operations might be integrated in the same type of hardware, while the service differentiation is operated by separate control software.

This section describes preliminary descriptions of the following points:

- Layer 2 switch interfaces interconnection
- Layer 3 routing interfaces interconnection
- Implementation of quality of service in the node architecture
- Initial options for integrated L2-L3 switching and control

3.3.1 Layer 2 switch interfaces interconnection

One of the main goals in the design of the electronic switching layer of the DISCUS architecture is to avoid duplicating functionalities of electronic components as much as possible, in order to reduce cost and energy consumption.

Interfacing L2 switching and the OLTs is an area for potential duplication of function. PON systems were often built as complete entities such that an OLT shelf would have line cards terminating a number of PON systems these would plug into a back plane which would also have slots for Ethernet switch cards network interface cards and management and control cards. The interface from these OLT shelves would be via “grey” optical interfaces usually at 10Gb/s and would connect either to a large carrier class Ethernet switch or a layer 3 router.

More recently in the access network multiservice access nodes (MSANs) have been designed with PON OLT cards as a pluggable option. In DISCUS the MSAN can be displaced and instead the OLT cards could be directly connected as interface cards to a L2 (Ethernet) switch. DISCUS will encourage integration of OLT cards into carrier class L2 switches to minimise the number of grey optical interface cards that would be required for example integration of OLT cards could save at least two grey interface cards and at least one electronic backplane interface saving both cost and power consumption. The integration of the OLTs

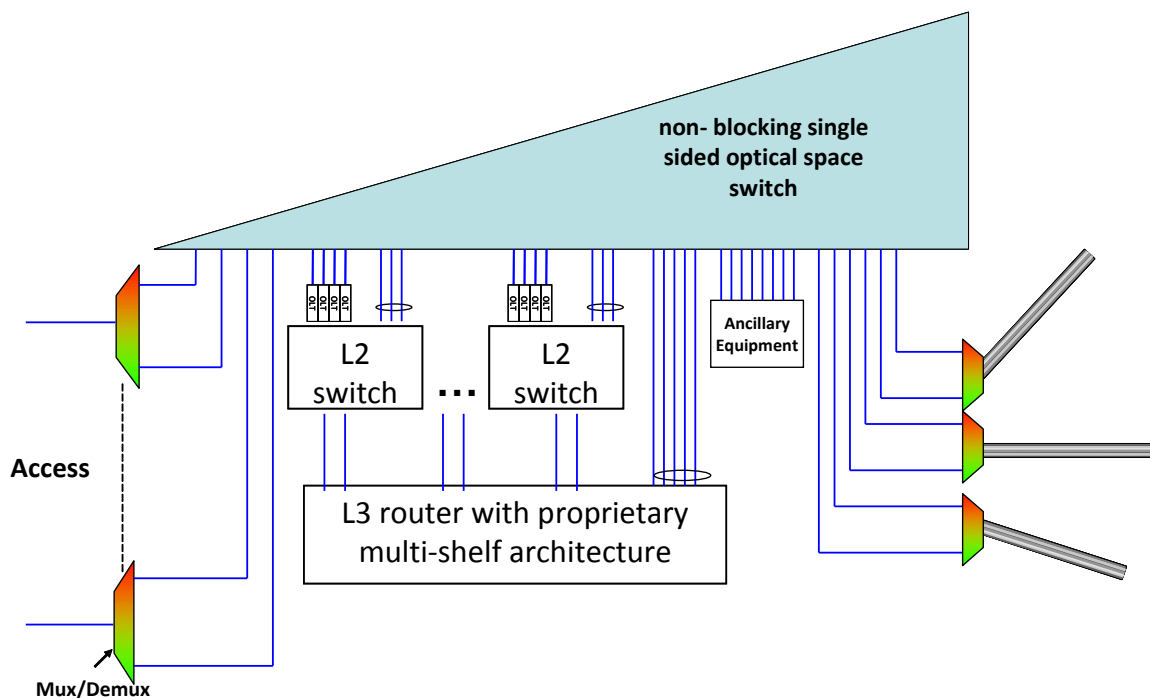

Figure 38 Metrocore none with multiple L2 switches and L3 scalable architecture

into the L2 switch may however limit scalability of the L2 switch. Therefore one option we will investigate is to build a multi-stage architecture where a number of L2 switches aggregate into one L3 router, as shown in **Error! Reference source not found.**

Because DISCUS will enable point to point and bespoke network as well as interfaces to legacy systems there will be a requirement for L2 interfaces to be available separately from the LR-PON OLT interfaces. To provide full flexibility of these other L2 interfaces they will be connected directly to the optical switch by using interface cards with DWDM extended-reach optical transceivers/transponders.

The L2 switch will also need to connect to the L3 router through grey interfaces while again some L3 ports will also need direct connection to the optical switch layer using long reach DWDM transceivers/transponders.

L2 interfaces to the optical switch could also create point-to-point or multi-point connections to other core nodes. Ideally a number of DWDM extended-reach interfaces could be dedicated to this purpose and used on-demand when a request arises (for core transmission paths these would effectively be transponders embedded into the L2 switch).

Another option is to keep extended-reach transponder interfaces as ancillary equipment, and use low-cost grey-interfaces at the switch to connect to them on demand, thus sharing expensive transponders between the L2 switch and L3 router, Modelling work in DISCUS will determine the relative cost and power consumption benefits of these strategies.

3.3.2 Layer 3 router interfaces

In current PON systems usage the OLT only provides transparent L2 connectivity, while the incoming connections from the user ONUs terminate logically at the IP router, which operates functions of authentication, authorization and address leasing. A number of short-range interfaces are thus used to aggregate user traffic from the L2 switch to the L3 router. The L3 router also operates as aggregator of L2 switches, assuring interconnection towards the core, as well as switching local traffic between different L2 switches.

Similarly for the L2 discussion, adopting DWDM extended-reach transceivers interfaces directly at the router, saves cost and power consumption, by reducing the amount of grey interfaces. However DISCUS will evaluate more in depth the cost vs. reconfigurability of the option of placing DWDM interfaces as ancillary equipment where they can be shared with other services (i.e., L2 services).

Finally, where a completely flat optical core is not economically advantageous, the L3 router also operates traffic grooming from a number of other nodes into core wavelength.

3.3.3 Implementation of Quality of service

One of the tasks the metro node needs to take care of is that of providing adequate Quality of Service (QoS). In the upstream direction, QoS is handled by the Dynamic Bandwidth Assignment (DBA) mechanism at the OLT, which determines the rate at which users are allowed to transmit packets. The issue arises however in the downstream direction, where the bandwidth feeding the L2 switch or L3 router from the network side is larger than the rate of any PON. While in past GPON implementations this was not a major issue, as often the total capacity feeding a central office was less or equal to the peak rate of a PON, the issue is different in LR-PON. As a core node now aggregates traffic from hundred thousands users, the aggregated traffic will be much larger than the peak rate of any one PON. If no QoS is implemented, when congestion occurs at the output port of the electronic (L2 or L3) switch, (i.e., if the rate of data destined for a particular PON exceeds its peak rate), packets will be dropped randomly. Since the packet drop occurs at the switch, this problem cannot be dealt by the OLT (differently from the upstream case), but needs to be dealt where the congestion occurs (i.e., at the L2 switch or L3 router). The adopted solution is likely to include a mix of techniques, such as differentiated services for assured, non-assured and best effort traffic (following the XGPON bandwidth classification), and call admission control (CAC).

We will initially target QoS within the boundary of an optical island, and then try to extend it also for inter-island QoS, to achieve a complete end-to-end solution.

3.3.4 Integrated L2 and L3 switching and control

Over the past few years, OpenFlow and Software Defined Networks paradigms have shown us that many network concepts we were used to believe as fundamental for network operations were instead only one possible solution. As

far as electronic packet processing is concerned L2 and L3 switching can be achieved with the same hardware with similar complexity. In addition the data plane of L2 or L3 switch can be totally separate from their control plane. This leads to the idea of having fast switching hardware that is almost protocol agnostic on one side, and a control plane that makes decisions on the switching and routing tables on the other side. Many network functions that were tightly coupled with a switch function, can now be virtualized and executed on an independent computation element, following the Network Function Virtualization (NFV) concept.

The data plane of L2 and L3 can then be integrated into the same hardware, with a number of obvious advantages:

- Better sharing DWDM interfaces for L2 and L3 services
- Avoid grey interfaces to connect L2 and L3 hardware
- Reduction of number of optical switch ports required in the node
- Integration of L2 and L3 network control, implemented on a separate computation element.

From an architectural point of view, merging the L2 and L3 data plane can bring issues of scalability and resiliency. As the number of users served by a metro-core node grows in the order of hundred thousand or more, it is not scalable to consider a monolithic switch carrying out all electronic packet processing

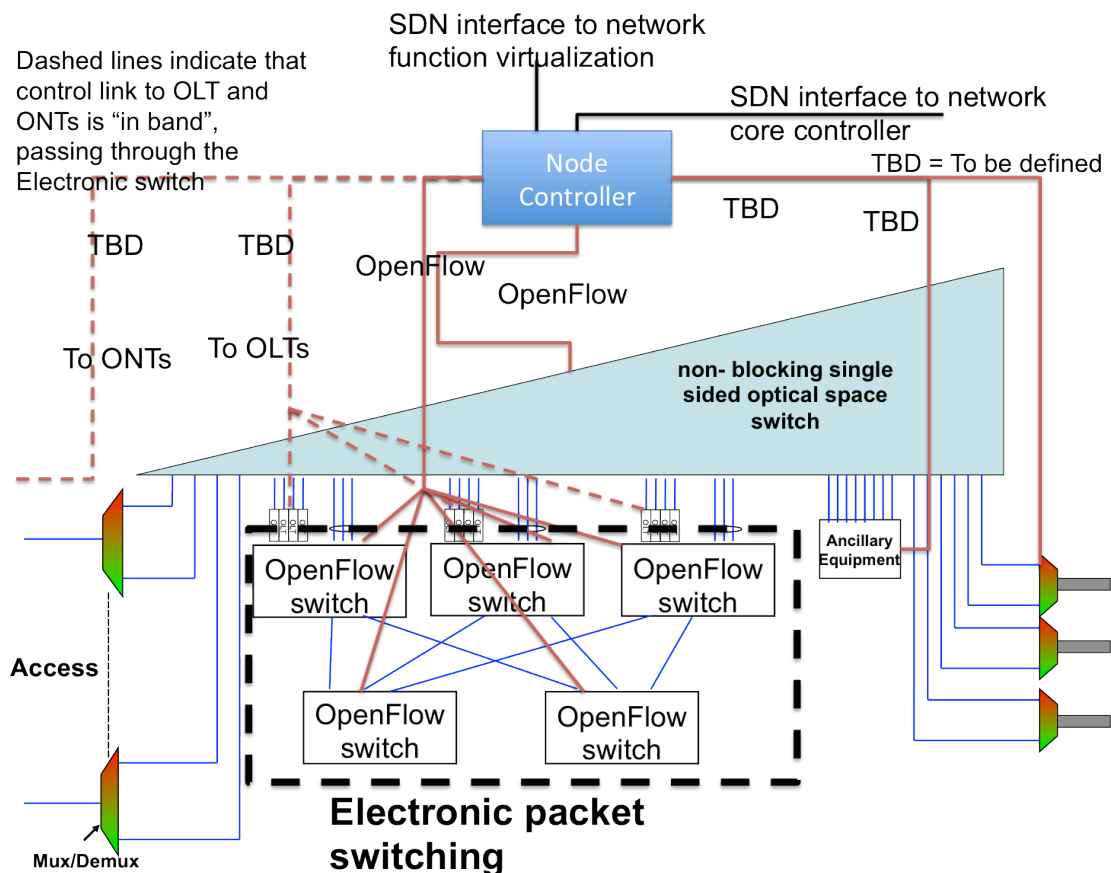

Figure 39 OpenFlow based control plane with L2 and L3 switching intergration



functions in the node. Rather than adopting a classical hierarchical structure where one L3 router serves multiple L2 switches, a multi-stage electronic switch can be implemented using protocol agnostic packet switches, controlled by an OpenFlow/SDN control plane (see **Error! Reference source not found.**).

4 The flat optical core network

The purpose of this section is to define the reference core architecture that implements the DISCUS end to end flat network concept and is applicable to all European countries. This architecture will be compliant with the ITU-T vision of Next Generation Network (NGN) and will be designed to provide the network services required by present end users applications and the ones that can be envisaged in the future.

4.1 Compliance with NGN architectural standards

The approach to DISCUS core network definition is based on the concepts of ITU Recommendation Y.2011 [17]. According to this Recommendation the network is divided into 2 strata:

- the transport stratum encompasses all functions devoted to digital data transfer between geographically separated points;
- the service stratum encompasses all functions devoted to implementation of end users applications.

This concept is shown in Figure 40.

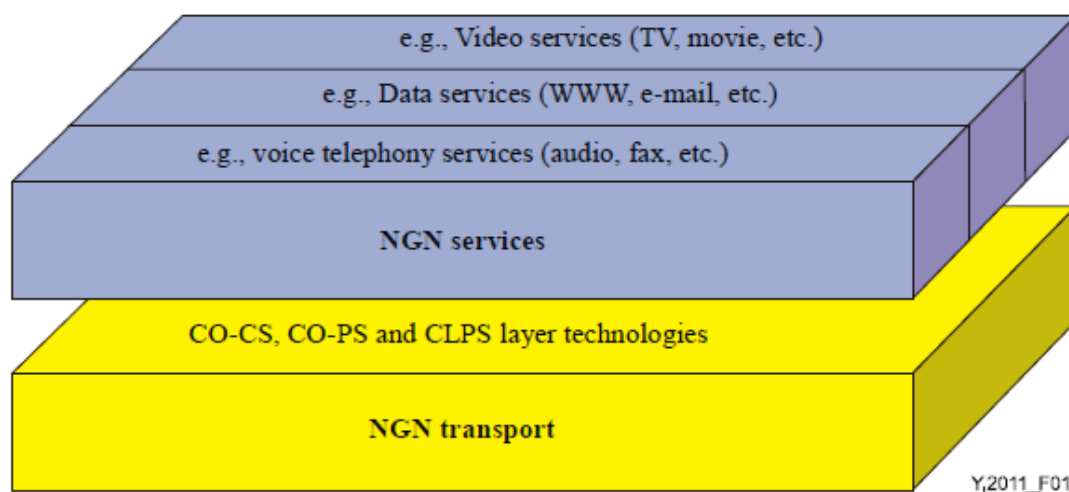

Figure 40 Separation of service stratum and transport stratum (from ITU-T Recommendation Y.2011)

Each stratum includes one or more layers that are composed of a data plane, a control plane, and a management plane.

According to this vision, the transport stratum provides network services to the service stratum matching end users application requirements. Since today the reference technology for the service stratum is the IP protocol and this paradigm will probably remain basically unchanged for many years in the future, the transport stratum must provide layer 1 through layer 3 transport services for

the IP service layer. This is one of the fundamental drivers highlighted in next paragraph.

A second useful input of the NGN standards comes from ITU-T Recommendation Y.2012 **Error! Reference source not found.** that contains the NGN connection scheme shown in Figure 41. The DISCUS core network will be able to provide all connections shown in the right hand side of Figure 41, i.e. the ones towards other networks or service providers, through appropriate interfaces.

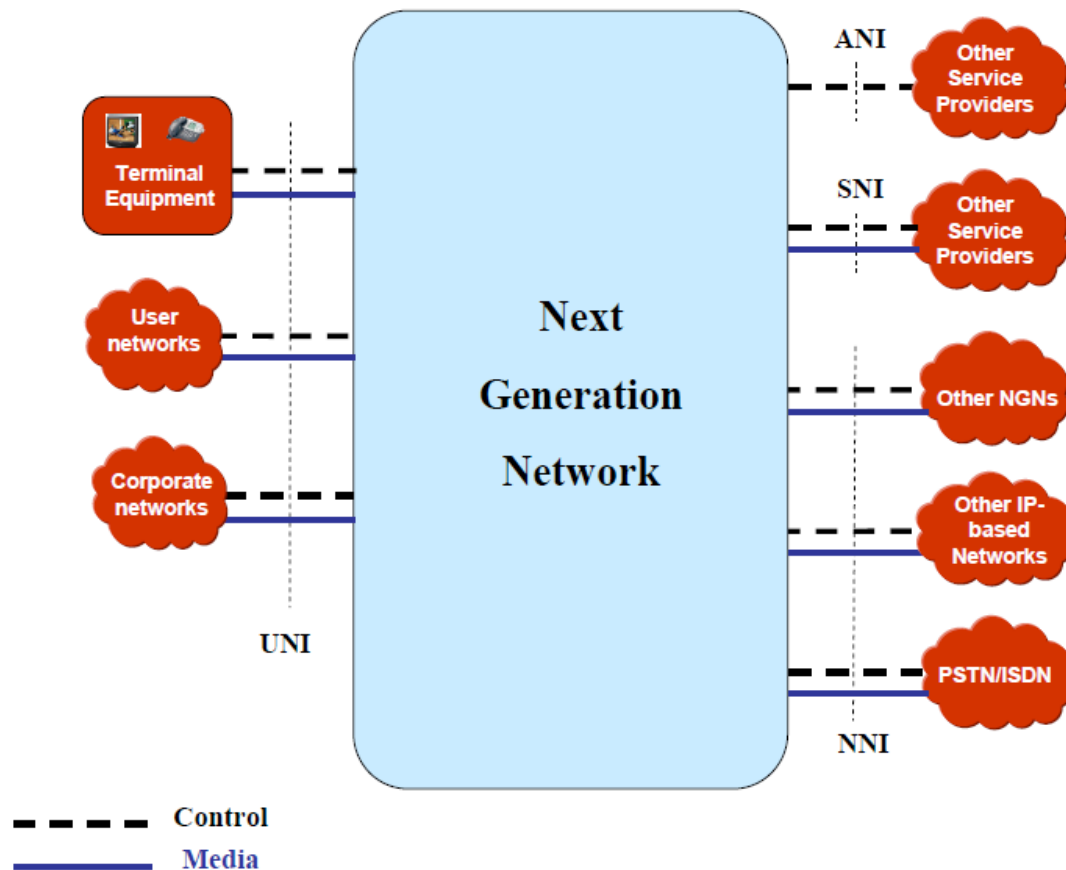

Figure 41 Possible connections of an NGN with users and other networks or providers (from ITU-T Recommendation Y.2012)

4.2 Core architecture drivers

Beside the normative drivers identified in previous paragraph, DISCUS core architecture is defined based on scalability, cost and energy efficiency, and seamless evolution criteria. The whole set of DISCUS core network drivers can be summarized as follows.

1. Normative drivers:
 - a) DISCUS core network provides circuit and packet transport services for the IP service layer considered in its present architecture and possible evolutions in a 5 year time frame;
 - b) DISCUS core network provides connections with other networks or service providers as shown in Figure 41, wherever needed;

2. Seamless architectural evolution driver:
 - c) DISCUS core architecture will be defined to seamlessly evolve in parallel with IP networking evolution (e.g. change of peering points number and traffic patterns)
3. Traffic scalability and cost and energy efficiency drivers:
 - d) DISCUS core architecture will exploit innovative photonic technologies as much as possible to ensure cost and energy efficiency;
 - e) DISCUS core architecture will provide also optimized packet transport functions to accommodate effectively low size traffic demands.

Drivers a) and b) deserve some further clarifications.

They are directly derived from ITU-T Recommendations Y.2011 and Y.2012, however, the kind of transport services provided by the core network may range from layer 1 to layer 3 with different technologies options. In optical networking community it is a common opinion that layer 3 transport, i.e. the transport and switching of IP packets by means of routers, is neither cost nor energy efficient based on present IP routers characteristics. On the contrary, circuit switched ROADM/DWDM and MPLS-TP packet switched technologies represent the technologies of choice for today's and future transport networks [19], and therefore they are selected as the reference technologies of the DISCUS core network as well. The main features of these technologies are concisely described in the following paragraphs together with their advantages for DISCUS core network.

Based on these considerations, we can derive a general picture of DISCUS Metro Core node functionalities combined with a high level IP service stratum scheme which is very useful for core architecture definition. This picture is shown in Figure 42.

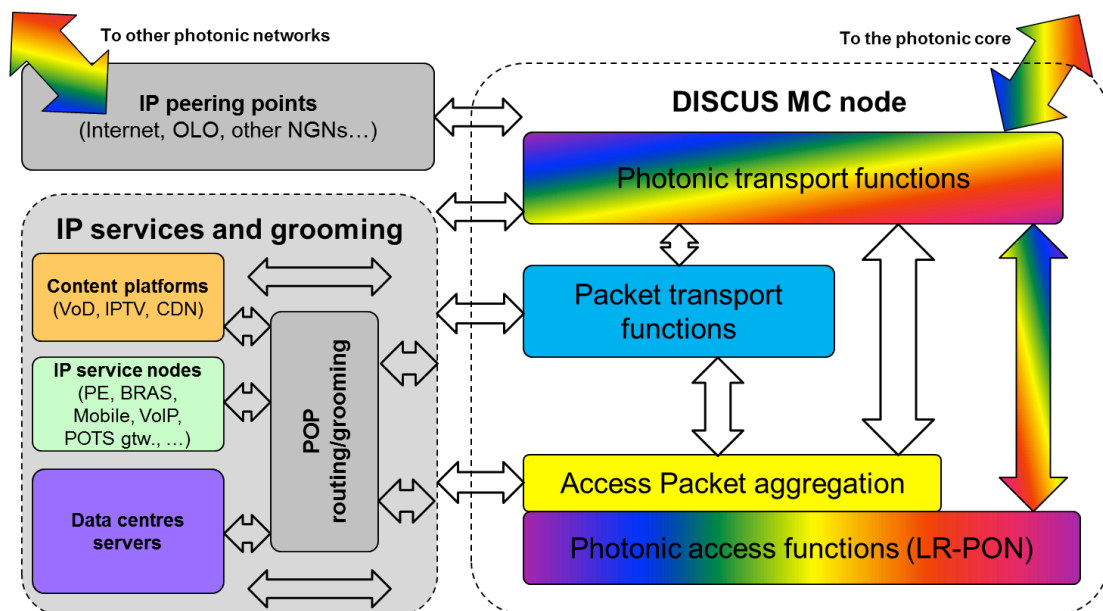

Figure 42 DISCUS MC node functional scheme and connections with IP service functions

The box on the right represents the actual family of transport functions provided by DISCUS core network (access functions are shown only for

completeness), while the two boxes on the left represent the IP service stratum (IP services and grooming) and IP interconnection functions with Internet, Other Licenced Operators (OLO), and possibly other NGN networks.

Even if a detailed architecture of the IP service stratum is outside DISCUS scope, the service functions highlighted in Figure 42 are the fundamental ones:

- content platforms upon which Content Distribution Networks (CDN) are based that provide applications like Video on Demand (VoD) and Voice over IP (VoIP);
- service routers, such as PE and BRAS (for business and residential customers respectively), mobile and VoIP service nodes, gateways towards POTS legacy networks, and so on;
- node aggregation routers devoted to traffic grooming and routing (some of these grooming functions may be performed at layer 2, but IP routing may be needed anyway for some others);
- peering points routers for interconnections with the Internet, OLOs and other NGN networks.

4.3 Photonic layer and transmission technologies

Photonic layer is a circuit switched optical network based on ROADM switching nodes and DWDM transmission systems. In the following the main characteristics of such technologies are outlined and a general approach to transparency islands design is proposed.

Uncompensated DWDM systems based on coherent optical channels spaced close to the Nyquist limit are already available and will become soon the state of the art in transmission technology. Therefore they represent the reference transmission technology for DISCUS core network. Their main characteristics are:

- baud rate up to 32 Gbaud;
- configurable modulation format: DP-BPSK, DP-QPSK, and DP-16QAM corresponding to 40, 100 and 200 Gbit/s per carrier (DP-8QAM corresponding to 150 Gbit/s may be considered as well);
- digital to Analog Converters in the transmitter enabling electrical spectral shaping and very tight channel spacing;
- soft decision FEC with coding gain higher than 10 dB.

A non-negligible advantage of such systems is that their performance can be accurately predicted not only by numerical simulations but also by more practical semi analytical model [20]. The details of these transmission degradation models will be the subject of other DISCUS deliverables, but the main results are summarized in Figure 43 where the reach of coherent systems with four different modulation formats is shown in function of channels spacing.

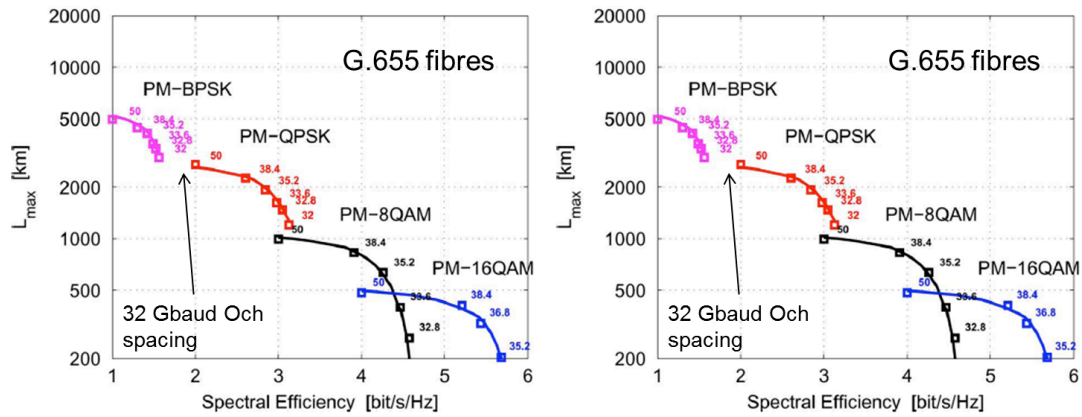

Figure 43 Transmission performance of 32 Gbaud coherent systems from reference [20]

It is evident that there is a trade-off between system reach and spectral efficiency: the longer the reach the lower the spectral efficiency that can be achieved. Moreover, even if system reach shown in Figure 43 is slightly optimistic, a transparent transmission distance of about 3 thousand kilometres can be obtained with PM-QPSK modulation format on G.655 fibres. In case of shorter transmission distance, higher spectral efficiency modulation formats can be used leading to a better optical spectrum exploitation. This means that the photonic layer can be a single transparent network domain for most European countries.

In other words, the concept of transparency islands as envisaged in DISCUS original proposal can be revisited: the whole core network can be a single transparency island where modulation format is adapted to the traffic demands reach requirements. This concept is shown in Figure 44 and will be the preferred option for DISCUS photonic layer.

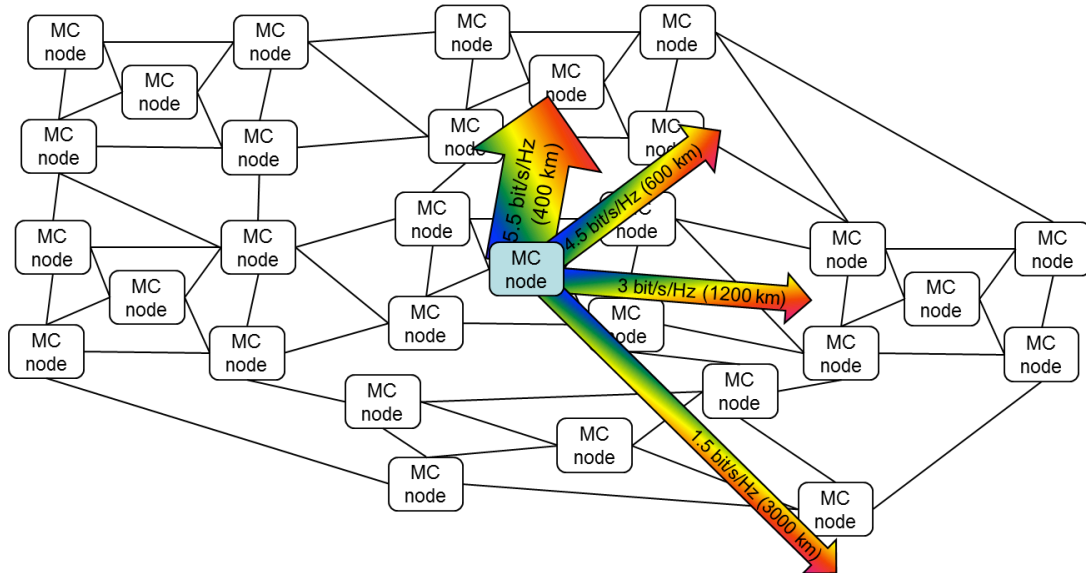

Figure 44 Fully transparent photonic layer based on modulation format-adaptive transponders

The photonic layer is fully flat network and all photonic connections between any couple of nodes are transparently feasible (in case some traffic paths are longer than the maximum achievable reach, appropriate regenerators allocation strategies will be adopted). However, not all possible connections must be used,

just the ones characterized by larger traffic demands where photonic technologies provide the lower cost and energy per bit.

Capacity and efficiency of this kind of photonic layer can be remarkably improved if flexible DWDM grid is used. The flexible grid concept has been standardised in the last version of ITU-T Recommendation G.694.1 [21]. According to this standard, the grid is organized in 12.5 GHz slots that can be grouped to form a wider bandwidth optical channel whose centre frequency can vary in steps of 6.25 GHz. Any optical channel on the grid is identified by two integer numbers: index n is the position of the centre frequency with respect to the reference frequency 193.1 THz, and index m (even positive number) is the number of 12,5 GHz slots that form the channel. An example of such flexible grid is shown in Figure 45.

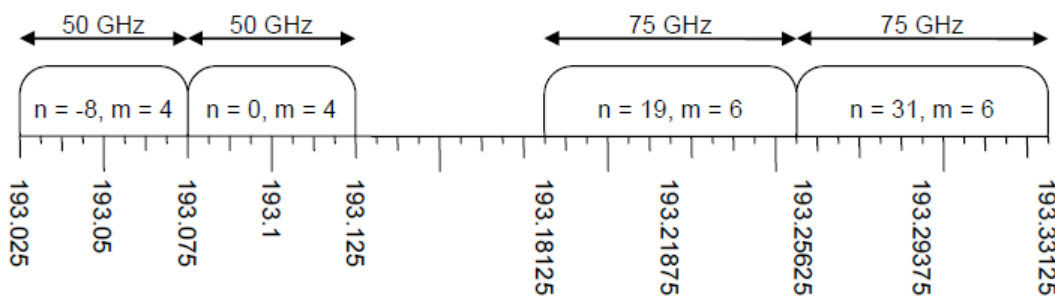

Figure 45 Example of flexible frequency grid from ITU-T Recommendation G.694.1

A simple example of the improvements that can be achieved using flexible grid instead of the normal 50 GHz DWDM channel spacing is the increase in channel number. Considering 32 Gbaud optical channels with a properly shaped spectrum, their spacing can be decreased from 50 to 37.5 GHz and therefore the total channel number in C band rises from typically 88 to perhaps 120. The total link capacity increases accordingly.

In a more sophisticated approach, bandwidth variable transponders may be used to generate optical channels and super channels (i.e., aggregation of optical channels that are switched together in the ROADMs) to fully exploit flexible grid potentials. This concept is described in reference [9] and in Figure 46.

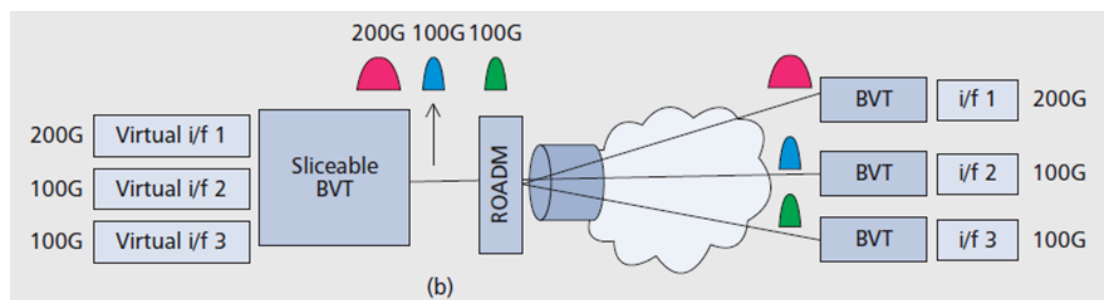

Figure 46 Bandwidth variable transponder concept from reference [9]

Appropriate strategies to exploit flexible grid and bandwidth variable transponder in DISCUS core network will be investigated in relevant deliverables.

4.4 Packet transport layer

The packet transport layer is a packet based transport network that complements transport capability of the photonic layer for small to medium size traffic demands. Its architecture is shown in Figure 47 where the client-server relation with the photonic layer is highlighted.

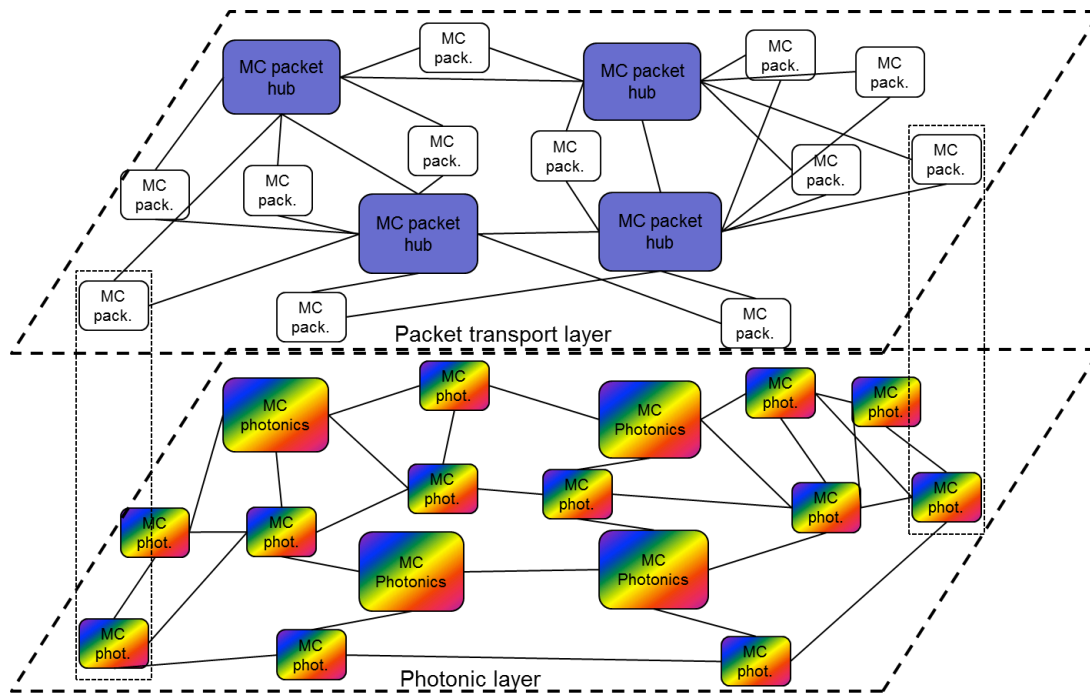

Figure 47 Packet transport layer and the underlying photonic layer

Figure 47 shows a conventional “hubbed” packet transport layer architecture where four nodes have been selected as hubs and all other nodes are double homed on two of these hubs. This is just one of the architectural options that are widely used in data networks. In DISCUS the most effective organization of the packet transport layer will be investigated based on suitable optimization criteria.

The packet transport layer satisfies the need to overcome the pure L2 Ethernet switching functionalities that have strong limitations in terms of possible traffic loops and VLANs scalability. Traffic loops may occur every time the MAC Forwarding database has no information about the forwarding ports (for example when aging time expires), so that traffic flooding occurs towards all output ports (broadcast traffic). Traffic segregation to the so-called 802.1q Virtual LAN, that creates a separated traffic switching domain that can range, for example, all over a metropolitan network, introduces some scalability problems because, even if QinQ Customer/Service-VLANs can be used, the network provider only manages the outer VLAN ID, that goes from 1 to 4096 all over the network.

A more sophisticated L2 switching can be achieved with packet switching based on MPLS (Multi-Protocol Label Switching) or on MPLS-TP (MPLS-Transport Profile), this last one also named Packet Transport. Both frameworks have already been deeply analyzed in the context of the ICT STRONGEST Project, focusing on recent “seamless MPLS” approach as defined by IETF [22] and the MPLS-TP solution as defined by IETF and ITU-T. As a matter of fact, these

standardization bodies have cooperated in order to approve at the end of 2012 the MPLS-TP standards: ITU-T Recommendations G.8110, G.8110.1 and IETF RFC5654, RFC5860, RFC5921, RFC6371, RFC6378.

The main characteristics and advantages of both the MPLS and the MPLS-TP frameworks with respect to a pure L2 Ethernet based switching can be summarized as follows.

- The service and transport entities of the MPLS (-TP) frameworks are respectively named Pseudowires (PWs) and Label Switched Paths (LSPs).
 - The native L2 802.1q Ethernet client traffic is encapsulated at the UNI sides of the MPLS(-TP) network into the PWs, that match 1:1 with the Ethernet VLANs at the UNIs.
 - The traffic is transported and switched over the LSP, that is a further MPLS (-TP) encapsulation collecting more PW labels, thus creating an end-to-end transport path with characteristics similar to the connection-oriented technologies.
- In the MPLS (-TP) approach, even if we use the same VLAN ID for different customers/services over different UNI interfaces, we can uniquely identify them with their own PW Identifier all over the network, that is linked to the PW labels at the very end nodes. These PW labels have local significance, i.e. they have significance only at equipment level and in theory could scale to 2M labels together with the LSPs labels, even if at present the technology allows managing only some tens thousands labels for each node.
- The LSPs switching on the MPLS (-TP) network avoids the traffic loops that can occur with VLAN switching on a pure Ethernet network, as discussed above.

Looking at peculiar seamless MPLS framework features, the main ones are described in the following.

- It is based on the paradigm of supporting all service types (from residential to business and mobile) through a single IP/MPLS control and forwarding plane framework, that goes from access nodes through metro and backbone nodes, these last ones being managed as transport nodes (with a reduced set of the IP/MPLS protocol suite, including LDP and BGP with their different flavors) in order to deliver traffic to the service nodes.
- For this purpose, at transport level a new entity is introduced, named "Transport Pseudowire", whose label can for example identify an access node with respect to a specific service node. These end-to-end circuit can be configured with an automatic Targeted LDP (T-LDP) session.
- LDP is also used for label distribution on transport paths (LSPs) all over the network, creating point-to-multipoint forwarding states towards the N service nodes that grow as $O(N)$. This LDP native scaling property

allows to overcome the scalability issues previously met with MPLS-TE based on RSVP-TE, that creates P2P LSPs growing as $O(N^2)$.

- OAM can be applied at PW level for end-to-end performance monitoring and the protection mechanism based on Loop-Free Alternates Fast ReRoute, that exploits pre-calculated back-up paths, assures about 200 milliseconds convergence times.

Quite significant characteristics differentiate MPLS-TP framework from seamless MPLS. The main ones are in the following.

- The control plane is separated from the data plane, in order to achieve the same characteristics of connection oriented transport networks in terms of end-to-end OAM and availability performances.
- OAM capabilities based on ITU-T recommendations G.8113.1 or G.8113.2, like connection monitoring and fault localization, are obtained by configuring bidirectional LSPs without Penultimate Hop Popping. In particular, OAM on PW, LSP and Section are based on Continuity Check (CC) and Connectivity Verification (CV) signaling and trigger Automatic Protection Switching (APS) [G8131] or Protection State Coordination (PSC) [RFC6378].
- The OAM based resilience mechanisms allow for recovery times below 50 milliseconds. In particular, these resiliency protocols are 1+1 or 1:1 linear end-to-end trail protection or ring protection like wrapping (a sort of MS-SPRing) and steering (a sort of SNCP). Multi-segment PWs, i.e. PW switching on equipment delimiting different sub-networks, can also be configured to allow recovery from failures occurring on different points along the network or, as an alternative, a 1:1 sub-network connection sub-layer (SNC/S) protection can be configured. Also OAM performance monitoring information like signal degrades on LSPs or PWs can be used to give a threshold below which APS can start.
- The equipment are fully carrier class, not only in terms of redundant common parts, but also in terms of In Service Software Upgrade (ISSU) that allows traffic recovery within 10s milliseconds in case of software release upgrade.

The packet technology that can be considered the best choice for DISCUS core network is MPLS-TP Packet Transport framework, that is preferred to the IP/MPLS framework for two main reasons:

- it is connection oriented and this remarkably facilitate network Operation Administration and Maintenance (OAM);
- the OAM supports “transport-like” protection mechanisms similar to the ones available in the SDH networks.

As a matter of fact, an MPLS-TP network assures service recovery times lower than 50 milliseconds, better than hundreds of millisecond times available in a pure or seamless IP/MPLS network.

In any case, we must hold in due consideration the following points that involve the core and the metro/access networks:

- in the access segment, the standardization bodies (in particular the WT-178 of the Broadband Forum) are considering the introduction of seamless MPLS for new generation GPONs;
- in the metropolitan areas, although there is still a significant deployment of native Ethernet MANs, many operators have already substituted them by alternatives based on IP/MPLS;
- the MPLS solution is already deployed in most of the telecom operators backbone IP routers networks and it will probably be available also on IP service nodes.

Therefore, the MPLS-TP choice for the transport layer requires some studies on interworking methods between the MPLS and the MPLS-TP frameworks.

To summarize, the Packet Transport approach assures the packet connectivity between any couple of nodes by LSPs encapsulation and switching. As shown in Figure 47, the Packet transport layer exploits the optical transport services provided by the underlying photonic layer in order to have the physical connectivity. Furthermore, the LSPs grooming over lambdas in the hub nodes allows a proper exploitation of photonic circuits.

Appropriate design criteria for the packet transport layer of the DISCUS core network will be the subject of future deliverables.

5 End to End design considerations

This report has provided a description of the initial architectural design of the DISCUS architecture. The report has been divided into sections that describe the parts of the architecture and it could be construed that the project is just designing the set of components and subsystems required for the whole architecture. However DISCUS is not simply a collection of pieces fitted together to form a whole but is an end to end design process where the collective design feeds back and affects the design of the pieces.

This is a challenging approach and there will be a natural tendency for experts in a particular area to focus on the design details and technological issues of that part of the architecture.. To overcome this natural tendency in the design process the modelling activities and in particular the optimisation aspects of the modelling will investigate interactions between design pieces and the tensions that will arise, and will aim to provide the guidance to the respective designers where a trade-off in one part produces a bigger benefit in another part of the architecture so that an agreed overall design is determined and is of most benefit to the end to end design.

It is recognised that the problem of the overall design is much too large for a complete end to end optimisation and heuristics plus individual stand-alone models will be used in conjunction with optimisation techniques to guide us to “good” solutions even though they cannot be proven to be ideally “optimal”.

An example of this will be the design of the core network and LR-PON access-metro network. To reduce costs in the access network the reach and sharing level of the LR-PON would be as long and as large as possible which would reduce the number of core nodes to a minimum. However the core node design tends to push in the other directions and increase the number of core nodes and reduce the size of the access network. Clearly there will be a compromise that is some optimal position balancing these two tensions and it will be the modelling and optimisation activities that will be used to determine the compromises and steer the design solution. This solution will in turn need to be tested by evolution, traffic and service growth scenarios to ensure a local minimum or optimisation has not been found and that the solution will be flexible and robust to possible change and uncertainty.

6 Summary/Conclusions

The objective of this report is to provide a working description of the DISCUS architecture to act as a guide for the designs to be undertaken by the project partners. It will be used to ensure there is a common understanding of the DISCUS philosophy and technical aspects of the target architecture. The report has many options within the various parts of the end to end architecture. These options will be examined and tested as the project progresses as a result options will be discarded also with learning from the project new options will arise. For some parts of the architecture there may be more than one options to tackle the variations that will arise in any real network however those variations will be kept to a minimum and will be based on underlying technologies and principles.

The designs will be tested within the concept of the end to end architecture not just the piece parts they will also be tested for robustness to change and uncertainty using evolution and service scenario and traffic modelling.

The report is divided into the major sections of the architecture with an introductory section describing the overall objectives of the DISCUS architecture and the logic the drives us to the end to end solution we have proposed in this document.

The overall objective is to deliver the design of a future architecture that can deliver ubiquitous high speed broadband access to all users independent of their geographical location. It will do this and remain economically viable as user bandwidths grow by at least three orders of magnitude. At the same time improved energy efficiency will ensure significant power savings over current network configurations (of order 95%). It will therefore avoid any digital divide produced by geographical location and remain affordable.

The argument described in the introduction shows that the logical conclusion has to be fibre to the premises, to deliver the capacity irrespective of location, it also argues that future networks must share infrastructure and resources as far as possible to reduce and minimise cost per customer. A consequence of this is the necessity to minimise the amount of electronics and electronic processing of network traffic by massively reducing the number of traffic processing nodes in the network. This will be done by elimination of the majority of local exchanges or central offices.

The conclusion for the network design option is that shared access using long reach passive optical networks, by-passing local exchanges and eliminating separate metro/backhaul transmission networks replaces today's access and metro network. The core nodes and network should minimise traffic processing and network interfaces by evolving to a flat optical core interconnecting a relatively small number of metro-core nodes This core network forms an optical island that is defined as a set of nodes that are interconnected by wavelength paths without the need to drop and insert traffic at intermediate nodes.

The second section describes the LR-PON network design options. A key feature of the DISCUS proposal is to extend previous work on long reach PONs by ensuring flexible wavelength assignment is an available option for the evolution of the future network. A further unique aspect is to enable the transport of core capacity paths over the LR-PON infrastructure. This would allow any business (including service and communications providers) to be located anywhere including remote rural areas and yet have the capability of communications links and network services equivalent to those located in cities or close to core nodes.

Another aspect of the LR-PON design is to ensure that it can be economically delivered into sparse rural communities these areas will be an example for the requirement of alternative configurations of the LR-PON architecture while basing the design on the same underlying principles and technology as those used in dense urban areas. The objective will be designs that can serve the vast majority of rural customers without recourse to government subsidy, or limiting service capability (we recognise however that it is not possible to guarantee a design that can economically cover 100% of all potential customer locations).

A key design consideration of the LR-PON system is resilience and availability of the network. The basic design will have dual parenting of the LR-PON feeder/backhaul network onto two separated metro-core nodes. This will provide the basic level of resilience to all customers. Calculations need to be performed to quantify this level of network availability but the design of the DISCUS architecture should mean that basic availability will be better than that of today's networks. For customers wanting greater availability a number of resilience options for increasing reliability have been described including dual homing from the customers premises via two completely geographically separate fibre paths.

For customers wanting private and physically separate network capability between properties a number of bespoke network solutions running over the LR-PON infrastructure are described.

The basic LR-PON operates at 10Gb/s symmetrical capacity but consideration of 40Gb/s downstream has been included as one of the evolutionary design options.

Section 3 considers the metro-core node, in the DISCUS architecture these are the main (and within an optical island the only) electronic traffic processing nodes. The main principles of the metro-core node architecture is to have a transparent optical layer in the form of an optical circuit switch that all other network functions, links and electronic switching/routing layers connect to. The optical layer then allows any layer below the optical switch to grow or shrink independently as the network evolves and traffic grows or shrinks. It also doesn't distinguish between access ports and core connection ports and enables direct connection to and between optical paths in the access and core networks. This is part of the enabling of core capability to the access edge which is one of the major aims of the DISCUS architecture.

The metro core node section describes the optical switch layer options. The basis of the optical switch is beam steering technology which has the ability to grow to very large switch sizes while being very economic with optical switching

elements and also exhibiting very low optical loss. The optical layer also interconnects the other electronic layers which are the layer 2 switch and the layer 3 packet processing routers. The functional requirements and also the interconnection of these layers in the metro-core node architecture are described.

The optical switching layer also enables new protocols and switching/routing technologies even experimental technologies to be tried out in a real network environment without risking service disruption in the main network. If new systems prove viable and valuable then legacy systems could be gracefully displaced enabling complete change out, over time, of even Ethernet and/or IP/TCP.

The final technical section is a description of the core network architecture. DISCUS will be collaborating with the IDEALIST project on the core network design, it is expected that DISCUS will be complimentary although the philosophy for the DISCUS core network is the flat optical island and will probably be a hybrid design with a mix of flexgrid and fixed grid technologies co-existing within optical islands. Also because DISCUS is an end to end design while IDEALIST is a core network design based on flexgrid technology and principles there should be mutually beneficial compromise to the core design in both projects and sharing designs and models should realise a more efficient overall design and more efficient use of limited design resources.

The core network section also describes the interaction and evolution of the electronic layers which we describe as the packet processing layers. It is also recognised that the packet processing in today's internet tends to be concentrated on a relatively few large nodes and that this must be taken into account as part of the overall core network design and evolution process.

Finally it must be stressed that DISCUS is an end to end architecture design project and that end to end consideration must steer the whole design, the design of the parts and the technology options studied within the project. Modelling and optimisation activities carried out within the project and imported from other and previous projects will be a critical part of the overall design process providing the mechanism for comparing, eliminating and selecting the various options that could be parts of the overall DISCUS architecture.

References

- [1] D. B. Payne and R. P. Davey, *The future of fibre access systems?*, BT Technology Journal, (20) 4, 104-114, 2002
- [2] S. McGettrick, D. B. Payne and M. Ruffini, Improving Hardware Protection Switching in 10Gb/s Symmetric Long Reach PONs. OFC 2013.
- [3] C. Mas Machuc, J. Chen, L. Wosinska, M. Mahloo, K. Grobe. Fiber Access Networks: Reliability and Power Consumption Analysis. ONDM 2011.
- [4] K. Shiraki, M. Ohashi, M. Tateda. "SBS threshold of a fiber with a Brillouin frequency shift distribution". JLT 14 (1), 1996.
- [5] Ossieur, P.; Antony, C.; Naughton, A.; Clarke, A.M.; Krimmel, H. -G; Xin Yin; Xing-Zhi Qiu; Ford, C.; Borghesani, A.; Moodie, D.; Poustie, A.; Wyatt, R.; Harmon, B.; Lealman, I.; Maxwell, G.; Rogers, D.; Smith, D.W.; Smolorz, S.; Rohde, H.; Nettet, D.; Davey, R.P.; Townsend, P.D., "Demonstration of a 32 512 Split, 100 km Reach, 2 32 10 Gb/s Hybrid DWDM-TDMA PON Using Tunable External Cavity Lasers in the ONUs," Lightwave Technology, Journal of, vol.29, no.24, pp.3705,3718, Dec.15, 2011
- [6] K. Roberts, M. O'Sullivan, K.-T. Wu, H. Sun, A. Awadalla, D.J. Krause, and C. Laperle, "Performance of dual-polarization QPSK for optical transport systems," J. Lightwave Technol., 27, 3546-3559 (2009).
- [7] J. M. Tang, P. M. Lane, and K. A. Shore, "High-speed transmission of adaptively modulated optical OFDM signals over multimode fibers using directly modulated DFBs," IEEE J. Lightw. Technol., vol. 24, no. 1, pp. 429-441, 2006.
- [8] X. Q. Jin, J. L. Wei, R. P. Giddings, T. Quinlan, S. Walker, J. M. Tang, 'Experimental Demonstrations and Extensive Comparisons of End-to-End Real-Time Optical OFDM Transceivers With Adaptive Bit and/or Power Loading'. IEEE Photon. J., vol. 3, no. 3, pp. 500-511, 2011.
- [9] Z. Dong, J. Yu, H.-C. Chien, "Ultra-dense WDM-PON delivering carrier-centralized Nyquist-WDM uplink with digital coherent detection," OSA Opt. Express, vol. 19, no. 12, pp. 11100-11105, 2011.
- [10] O. Gerstel, M. Jinno, A. Lord, S. J. B. Yoo, "Elastic Optical Networking: A New Dawn for the Optical Layer?," IEEE Communications Magazine, issue 2, pp. s12-s20, 2012.
- [11] L. Liu, L. Li, Y. Huang, K. Cui, Q. Xiong, F. N. Hauske, C. Xie, and Yi Cai, "Intrachannel Nonlinearity Compensation by Inverse Volterra Series Transfer Function", vol. 30, no. 3, pp. 310-316, 2012.
- [12] S. L. Jansen, I. Morita, K. Forozesh, S. Randel, D. van den Borne, and H. Tanaka, "Optical OFDM: A hype or is it for real?," presented at the Eur. Conf. Opt. Commun., Brussels, Belgium, 2008, paper Mo.3.E.3.

- [13] E. Giacomidis, I. Aldaya, V. Vgenopoulou, I Roudas, Y. Jaouen, N. J. Doran, "Impact of reduced complexity Volterra-based nonlinear equalizer in coherent OFDM systems for next-generation core networks", [Invited] IEEE 15th International Conference on Transparent Optical Networks (ICTON), Cartagena, 2013.
- [14] W. Shieh, X. Yi, Y. Ma, and Q. Yang "Coherent optical OFDM: has its time come?," [Invited], IEEE/OSA J. Opt. Netw., vol. 7, no. 3, pp. 324-255, 2008.
- [15] C. Clos. "A study of non-blocking switching networks". Bell System Technical Journal, 32 (2), 1953.
- [16] M. Ruffini, D. Mehta, B. O'Sullivan, L. Quesada, L. Doyle, D. B. Payne. Deployment case studies of an energy efficient protected LR-PON architecture. ONDM 2012.
- [17] ITU-T Recommendation Y.2011, "General principles and general reference model for Next Generation Networks", (10/2004)
- [18] ITU-T Recommendation Y.2012, "Functional requirements and architecture of next generation networks", (4/2010)
- [19] S. Gringeri et al., "Flexible Architectures for Optical Transport Nodes and Networks", IEEE Comm. Magazine, July 2010
- [20] A. Carena, et al., "Modeling of the Impact of Nonlinear Propagation Effects in Uncompensated Optical Coherent Transmission Links", JOURNAL OF LIGHTWAVE TECHNOLOGY, VOL. 30, NO. 10, MAY 15, 2012
- [21] ITU-T Recommendation G.694.1, "Spectral grids for WDM applications: DWDM frequency grid", (2/2012)
- [22] N. Leymann, B. Decraene, C. Filsfils, M. Konstantynowicz, D. Steinberg, "Seamless MPLS Architecture, draft-ietf-seamless-mpls-02", October 2012

Appendices

Appendix (a) The L2 switch layer functionality

The DISCUS L2 technology of choice must consider both L2 access switching/aggregation requirements and L2 core switching/aggregation requirements. On the access side the switch should collect the Ethernet traffic coming from a certain number of OLTs, but a pure L2 802.1q solution with VLAN tag could have scalability problems due to the limited range of available VLAN IDs, that is between 1 and 4096. As a consequence, a seamless MPLS framework or an MPLS-TP framework could be necessary.

The seamless MPLS framework could be an option for the access packet switching/aggregation, in order to assure an end-to-end MPLS flavor from the OLT (with its L2 access switch) to the service nodes (i.e. the IP/MPLS service edge) through the IP/MPLS aggregation/routing nodes and peering points.

On the other hand, the MPLS-TP or Packet Transport (PT) framework is considered the best solution for the packet core switching/aggregation side in terms of carrier class features: OAM functions, common boards redundancy and in-service software upgrade.

Obviously, an heterogeneous choice would require some interworking coordination between the L2 access side functions and the L2 core side functions (as well as with backbone/peering IP/MPLS equipment). On the contrary, an end-to-end MPLS-TP solution from access to core segments would be self-consistent but, in any case, interworking issues should be considered for interconnections towards the IP/MPLS service and backbone/peering nodes.

In any case, both approaches would imply that the Ethernet switching is limited and mediated by services definition and MPLS(-TP) switching that, in particular, is based on PWs and/or LSPs switching/stitching.

Regarding services definition, E-Line, E-LAN and E-Tree services are available.

- The E-Line service is a point-to-point service identified at the very ends of the MPLS(-TP) network with a 1:1 mapping between the VLAN-IDs at the ingress/egress UNIs and the PW ID.
- The E-LAN service is a multipoint-to-multipoint service (for example the corporate LAN), for which the Ethernet switching can be isolated into Virtual Service Instances (VSIs), each one identified by a specific PW ID that matches the VLAN ID at the network borders, identifying the service across different points all over the network.
- The E-Tree service is a point-to-multipoint service (for example a multicast video distribution) that is under MPLS standardization developments. The service management on access packet side can be simply based on multicast VLAN distribution on GPON trees. On the contrary, the E-Tree service management at core packet level would imply the use of MPLS Virtual Private Multicast Networks (VPMNs). A possible implementation could be based on P2MP PWs or on an Hub&Spoke H-VPLS solution. The second one, that is nearly available today, could be based on VSI instances on the Packet Metro Core Hub nodes while the other Metro Core nodes act as bridging (i.e. with VSI) or non-bridging (i.e. without VSI) Spoke nodes, through the mediation of hub&spoke PWs.

Regarding MPLS(-TP) switching, the access side should primarily implement PWs labels switching/stitching, in order to support the services distribution all over the local GPON trees, i.e. in order to limit the pure Ethernet switching on the access side.

On the contrary, the core side should primarily implement LSPs labels switching/stitching, together with LSP grooming over photonic circuits, as described in paragraph. As a matter of fact, in the other alternatives, i.e. VLAN

switching/grooming or VPLS switching/grooming at VSI level, should be avoided because of the risk of Ethernet traffic loops.

Layer 2 switch interconnect to other layers

The switch interconnect to the other layers can impact the following couples of nodes:

- 1) The IP/MPLS(-TP) access switch and the MPLS-TP core switch
- 2) The IP/MPLS(-TP) access switch and the IP/MPLS service node
- 3) The IP/MPLS(-TP) access switch and the IP/MPLS aggregation/routing or peering node
- 4) The MPLS-TP core switch and the IP/MPLS aggregation/routing or peering node

If we use the same framework for both access and core sides, i.e. the MPLS-TP one, the switches interconnections for case 1) can be treated as described in the following, for the different services:

- E-Line service: the PW is created at the network borders, i.e. on access sides located in different nodes, and is kept untouched along the intermediate nodes forming the Core network, where it is preferable to apply switching at LSP level as well as grooming at Core Hub nodes
- E-LAN service: whenever possible, it is preferable to apply PW switching on the access side, so that the VSI must be connected to different incoming/outgoing PWs (for intra-PoP or inter-PoPs customer sites connections over different GPONs), while traffic is transported over the Core network at LSP level
- E-Tree service: we can make the same considerations done describing the L2 switch functionalities.

If the access switch is based on seamless IP/MPLS, the interconnection of the access network with the IP/MPLS service node (case 2) or with the IP/MPLS aggregation/routing and peering nodes (case 3) follows the seamless MPLS end-to-end paradigm..

On the other hand, the interconnection of an IP/MPLS access switch with an MPLS-TP core switch (case 1) or the interconnection between the MPLS-TP core switch and the IP/MPLS aggregation/routing or peering node (case 4) requires *interworking functionalities between the MPLS-TP framework and the IP/MPLS framework*.

These interworking functionalities have been partially studied in the context of the ICT STRONGEST Project and some of them are nearly commercially available. In particular, the interworking functionalities are based on a *network partitioning model*, as described in the IETF draft-martinotti-mpls-tp-interworking-02-July 2011. The network partitioning model is based on a peer

paradigm, i.e. the interworking of the IP/MPLS and the MPLS-TP frameworks is at the same level of the OSI protocol stack.

The protocol interworking can be done at PW or LPS level, with the following options:

- *PW stitching for Multi-Segment PW (MS-PW) creation*
- *Label Switched Paths (LSPs) stitching*

The interworking boundary for the network partitioning model can be classified as:

- *border link*, i.e. an interworking approach where equipment at the boundary between two domains use different technologies;
- *border node*, i.e. an equipment at the boundary of the two domains implements both technologies used in these two interconnected domains.

An MPLS-TP border node should have a complete set of IP/MPLS functionalities w.r.t. an MPLS-TP node at a border link, in order to support both the automatic, dynamic configuration of PWs and LSPs towards the IP/MPLS network as well as the pre-provisioned, static configuration of PWs and LSPs inside the MPLS-TP domain. Therefore, the border link solution appears simpler to be implemented, for example by upgrading the Metro Core node to support a GMPLS control plane in order to coordinate its border networks, where different MPLS flavors are used.

Regarding the MPLS labels interworking, the PW switching/stitching could be a viable solution for the IP/MPLS access switch, in order to limit the pure Ethernet switching at the access side. For example, if we consider PW stitching/switching at border link, we can have the following cases:

- *E-Line service*: PW stitching is applied, i.e. the PWs are created on each network segment (the MPLS access segments and the MPLS-TP core segment) and then stitched together on the access switch in order to form a MS-PW.
- *E-LAN service*: PW switching by VSI is applied, i.e. on access switch the PW segments created in the different domains are processed at Ethernet level by configuring a VSI instance that isolates the Ethernet switching to the traffic bounded to these PWs.
- *E-Tree service*: the interconnection should be studied in more detail, especially for P2MP PWs. On the contrary, the interconnection for a service model based on H-VPLS could be managed in a way similar to the E-LAN services.

On the other hand, LSP stitching at border link would be a viable solution for the packet core network, as it will be discussed also in paragraph. In this case we can consider to manage the E-Line, E-LAN or E-Tree service with their PWs on access side only, while the core switch processes traffic only at LSP level. There would be a coordination between the MPLS LSP label dynamically created in the IP/MPLS access switch and the static MPLS-TP LPS label created in the Packet Transport core switch, stitching together these different labels in order to create an end-to-end LSP across the different domains. This interworking model has

been considered in the IETF draft, but it still needs further studies for a complete definition.

Also the interconnection of the MPLS-TP core switch to the IP/MPLS aggregation/routing or peering node (case 4) could be modeled by LSP stitching on a border link. Besides, this solution would allow CAPEX savings for the IP/MPLS network, because traffic could be routed on a lower number of interfaces with the support of the so called “Virtual Links”, represented by LSPs configurable on the same physical interface, that identify different paths inside the IP/MPLS backbone. This allows an IP-offloading of the pass-through traffic and, as a consequence, the possibility to create a flat IP topology. In this sense, traffic on the MPLS-TP core switch should be managed at LSP level, and in particular LSP stitching on border link could assure the traffic continuity across the different domains.

Appendix (b) The L3 routing functionalities

For the L3 functionalities on Metro Core node, the access and core switches should be supported by a full or a reduced set of IP/MPLS routing and signaling functionalities, depending on the L2 framework choice on access and core sides, i.e. seamless MPLS or MPLS-TP. In particular, we can have the following requirements:

- For seamless IP/MPLS, a reduced set of the IP/MPLS protocol suite, including OSPF, LDP and BGP with their different flavors, is sufficient in order to create end-to-end PWs. In particular, the access switch on the OLT should have a “Light” IP/MPLS configuration, that means only the LDP Downstream on Demand (DoD) functionality for LSPs and PWs creation, in order to reduce the node costs.
- For MPLS-TP, a reduced set of IS-IS or OSPF routing protocols together with label signaling protocols like RSVP-TE or LDP are used only in order to create static, pre-provisioned LSPs, that assure fast restoration and end-to-end OAM in the core transport network. Some additional IP/MPLS functionalities could be required for the interworking between MPLS-TP and IP/MPLS networks (see paragraph 0).

In general, on the access switch some specific L3 protocols should be available, like DHCP Relay Agent for Video on Demand services and IGMP Snooping/Proxy for Multicast Video distribution.

Appendix (c) Network services requirements

The DISCUS Metro Core node should support all network services available in a Next Generation Network perspective. These services can be summarized as regards the customer groups:

- Residential services
- Business and Cloud Computing services
- Other Licensed Operators (OLOs) services
- Mobile 4G (LTE) backhauling services

The main end-user application characteristics, the network services description and the network segments involved together with the service nodes are summarized in Table 2

Table 2 Main network services requirements

CUSTOMER GROUP	END-USER APPLICATIONS	NETWORK SERVICE DESCRIPTION	NETWORK SEGMENTS & SERVICE NODES
RESIDENTIAL	<p><u>TRIPLE PLAY</u> applications, i.e.:</p> <p><u>VoIP</u> (Voice over IP) & <u>Internet</u> supported by PPPoE (PPP over Ethernet)</p> <p><u>VoD</u> (Video on Demand) supported by IPoE (IP over Ethernet)</p>	<p>point-to-point (p2p)/ E-LINE services</p>	<p>Access network to co-located PoP BRAS (Broadband Remote Access Server) and Video Server +</p> <p>+ Core network for backbone VoIP and Internet peering</p> <p>or</p> <p>Access + Core network to not co-located PoP BRAS and Video Server +</p> <p>+ Core network for backbone VoIP and Internet peering</p>
	<p><u>IPTV</u> applications (Broadcast TV) supported by IPoE</p>	<p>point-to-multipoint (p2mp)/ E-TREE service</p>	<p>Access network to co-located PoP IPTV Head End</p> <p>or</p> <p>Access + Core network to not co-located PoP IPTV Head End</p>

<p>BUSINESS/ CLOUD COMPUTING</p> <p>for</p> <p>LARGE ENTERPRISE</p> <p>and/or</p> <p>SMALL OFFICE/ HOME OFFICE (SOHO)</p>	<p><u>BUSINESS</u> applications, i.e: <u>VoIP (IPoE)</u> & <u>Internet (IPoE)</u> &</p> <p><u>L2/L3 VPN</u> (Virtual Private Network) inside Metropolitan Area Network (MAN)</p> <p>or</p> <p><u>IP/MPLS VPN</u> across MANs</p> <p><u>CLOUD</u> applications, i.e.: IaaS (Infrastructure as a Service) SaaS (Software as a Service) NaaS (Network as a Service) based on <u>IP or IP/MPLS VPN</u></p>	<p>p2p/E-LINE services for VoIP, Internet, IP/MPLS VPN across MANs and CLOUD</p> <p>multipoint-to-multipoint (mp2mp)/ E-LAN services for L2/L3 VPN inside MAN</p>	<p>Access network to co-located PoP PE (Provider Edge for VoIP, Internet, IP/MPLS VPN, NP Cloud) and NP/SP DC (Network Provider or Service Provider Data Center for Cloud) +</p> <p>+ Core network for backbone VoIP, Internet and IP/MPLS VPN</p> <p>or</p> <p>Access network for L2/L3 VPN inside MAN</p> <p>or</p> <p>Access + Core network to not co-located PoP PE & NP/SP DC +</p> <p>+ Core network for backbone VoIP, Internet and IP/MPLS VPN</p>
	<p><u>OTN circuit service</u> to the end business customer</p>	<p>p2p CBR OTN connections</p>	<p>SDH STM-X circuits or OTN ODU-X circuits between POPs in the Access and Core domains</p>
	<p><u>LAMBDA service</u> to the end business customer</p>	<p>p2p Optical connections</p>	<p>Lambda circuits, normally offered between couples of Core network sites</p>

<p>OTHER LICENSED OPERATORS (OLOs)</p>	<p><u>Wholesale services</u> , i.e.:</p> <p><u>PPPoE connections</u></p> <p>or</p> <p><u>ETHERNET access</u></p> <p>or</p> <p><u>LAMBDA service</u></p>	<p>p2p/E-LINE services</p> <p>as for p2p RESIDENTIAL customers or BUSINESS Internet and L3VPN or LAMBDA service</p> <p>mp2mp/E-LAN L2 service</p> <p>as for BUSINESS L2 VPN</p>	<p>Access network from OLO customer Access Point to OLO PoP Delivery Point (if not co-located also the Core network is involved) (p2p service)</p> <p>or</p> <p>Access + Core network for INTERNET access on the Network Operator IP national or international Peering Points (p2p service)</p> <p>or</p> <p>Access network for E-LAN service inside MAN (mp2mp service)</p>
<p>MOBILE BACKHAULING (LTE)</p>	<p>BROADBAND IP based MOBILE services</p>	<p>p2mp/E-TREE service</p>	<p>Access network to co-located PoP SEG (Security Gateway, that acts as PE towards the Mobile Core Network nodes or Evolved Packet Core-EPC) +</p> <p>+ Core network for backbone IP services</p> <p>or</p> <p>Access + Core network to not co-located SEG+EPC +</p> <p>+ Core network for backbone IP services</p>

Abbreviations

ALA	Adaptive Loading Algorithms
ALUD	Alcatel-Lucent Deutschland AG
APD	Avalanche Photo Diode
APS	Automatic Protection Switching
ASE	Amplified Spontaneous Emissions
ASK	Amplitude Shift-Keying
ASTON	Aston University
ATESIO	Atesio GMBH
AWG	Arrayed Waveguide Grating
BER	Bit Error Rate
BGP	Border Gateway Protocol
BMRx	Burst-Mode Receiver
BW	Broadband Remote Access Server
BW	Bndwidth
CAPEX	Capital Expenditure
C-band	Band in the wavelength range 1530–1565 nm
CC	Continuity Check
CD	Chromatic Dispersion
CDN	Content Distribution Networks
CO	Confidential, only for members to the consortium (including Commission Services)
CO-OFDM	Coherent OFDM
CoWDM	Coherent-WDM
CV	Connectivity Verification
DACs/ADCs	Digital-to-Analogue/Analogue-to-Digital Converters
DBA	Dynamic Bandwidth Assignment
DCF	Dispersion Compensating Fibre
DISCUS	The DIStributed Core for unlimited bandwidth supply for all Users and Services
DP	Distribution Point

DP-BPSK	Dual Polarization Binary Phase-Shift Keying
DP-QPSK	Dual Polarization Quaternary Phase-Shift Keying
D-side	Distribution side
DSL	Digital Subscriber Line
DSP	Digital Signal Processor
DWA-side	Dynamic Wavelength Assignment The distribution side of the access network, from cabinet location to distribution point
DWDM	Dense Wavelength Division multiplexer
EDC	Electronic Dispersion Compensation
EDFA	Erbium Doped Fibre Amplifier
E-Line	Ethernet Virtual Private Line
EON	Elastic Optical Network
EPON	Ethernet Passive Optical Network
E-side	The access network from the local Exchange site to the cabinet location
E-Tree	Ethernet Virtual Private Tree
FEC	Forward Error Correcting
FFT	Fast Fourier Transform
F-OFDM	Fast Orthogonal Frequency Division Multiplexing
FTTH	Fibre to the Home
FTTP	Fibre to the Premises
GA	Grant Agreement
GPON	Gigabit Passive Optical Network
ICT	Information Communications Technology
IETF	Internet Engineering Task Force
IFFT	Inverse Fast Fourier Transform
III-V	III V Layer-based GIE
IM/DD	Intensity Modulation/Direct Detection
IMEC	Interuniversitair Micro-Electronica Centrum VZW
IP	Internet Protocol
IPoE	IP over Ethernet
IQ	In-phase Quadrature-phase
ISI	Inter-symbol Interference
ISSU	In Service Software Upgrade

ITU	International Telecommunications Union
ITU-T	ITU's Telecommunication Standardization Sector
KTH	Kungliga Tekniska Hoegskolan
LAN	Local Area Network
L-band	Band in the wavelength range 1565–1625 nm
LBMRx	Linear Burst-Mode Receiver
LDP	Label Distribution protocol
LE	Local Exchange
LO	Local Oscillator
LR-PON	Long Reach Passive Optical Network
LSP	Label Switching Protocol
MAC	Media Access Control
MBW	Modulator Bandwidth
MC	Metro-core
MIMO	Multiple-input Multiple-output
MPLS	Multi-Protocol Label Switching
MPLS-TE	Multi-Protocol Label Switching Traffic Engineering
MPLS-TP	Multi-Protocol Label Switching Transport Profile
MSAN	Multi-Service Access Node
MS-SPRing	Multiplex section shared ring protection
NFV	Network Function Virtualization
NGN	Next Generation Network
NRZ	Non Return to Zero
NSN	Nokia Siemens Networks
OAM	Operation Administration and Management
OASE	FP7 project "Optical Access Seamless Evolution"
ODN	Optical Distribution Network
OEO	Optical-Electronic-Optical (conversion)
OFDM	Orthogonal Frequency Division Multiplexing
OFDMA-PON	PON based on OFDM access
OLO	Other Licenced Operators
OLT	Optical Line Termination
ONT	Optical Network Termination

ONU	Optical Network Unit
OOK	On-off keying
OPEX	Operational Expenditure
OSNR	Optical signal to Noise Ratio
PAPR	Peak-to-Average Power Ratio
PAYG	Pay As You Grow
PC	Private Circuits
PCP	Primary Cross Connect
PE	Provider Edge
PIEMAN	FP7 project “Photonic integrated extended metro and access network”
PIN-Rx	Positive Intrinsic Negative Receiver (Receiver with PIN photodiode)
PM	Phase Modulator
PMD	Polarization Mode Dispersion
PM-QPSK	Polarization Multiplexing QPSK
POLATIS	Polatis Ltd
PON	Passive Optical Network
PoP	Point of Presence
POTS	Plain Old Telephony Service
PP	Restricted to other programme partners (including Commission Services)
PPP	Point to Point Protocol
PPPoE	Point to Point Protocol over Ethernet
PSC	Protection State Coordination
PU	Public
PW	Pseudowires
QAM	Quadrature Amplitude Modulation
QoS	Quality of Service
RE	Restricted to a group specified by the consortium (including Commission Services)
RF	Radio Frequency
ROADM	Re-configurable Optical Add Drop Multiplexer
RSVP-TE	Resource Reservation Protocol - Traffic Engineering

RTT	Round Trip Time
SBS	Stimulated Brillouin Scattering
SDH	Synchronous Digital Hierarchy
SDN	Software Defined Networks
SNC/S	Sub-Network Connection Sub-Layer
SNCP	Subnetwork Connection Protection
SNR	Signal to Noise Ratio
SOA	Semiconductor Optical Amplifiers
STRONGEST	Fp7 project “Scalable, Tunable and Resilient Optical Networks Guaranteeing Extremely-high Speed Transport”
TCD	Trinity College Dublin
TDMA	Time Division Multiple Access
TDM-PON	Time division Multiplexed Passive Optical Network
TF	Tuneable Filter
TI	Telecom Italia S.p.A
TID	Telefonica Investigacion Y Desarrollo SA
T-LDP	Targeted-LDP
UCC	University College Cork
UD	Ultra-dense
UK	United Kingdom
UNI	User Network Interface
VLAN	Virtual Local Area Network
VLAN ID	Virtual Local Area Network IDentification
VN	Virtualised Networks
VoD	Video on Demand
VoIP	Voice over IP
xDSL	The suit of access techniques based on DSL
WAN	Wide Area Network
WDM	Wavelength Division Multiplexing
WDM-PON	Wavelength Division Multiplexed Passive Optical Network
WSS	Wavelength Selective Switch