

Start date of project: **23.05.2005**

Duration: **36 months**



**Project No. 012611**



**Development of an interoperable platform technology  
for safety related data transfer and safe  
communication in  
Local Operating Networks**

Instrument: **Collective Research**

Thematic Priority: **Horizontal Research Activities involving SMEs**

**Periodic Activity Report  
Reporting Periods I, II and III**

**Prepared by Dr. Jürgen W. Hertel  
(Consortium Manager)**

Period covered: from **23.05.2007** to **22.05.2008**

Date of preparation: **30.06.2008**

Start date of project: **23.05.2005**

Duration: **36 months**

Project coordinator: **Dr. Jürgen W. Hertel**

Project coordinator organisation: **LONMARK Deutschland e.V.**

## 1. Table of Contents

|   |           |
|---|-----------|
| <b>Periodic Activity Report.....</b>  | <b>1</b>  |
| <b>Reporting Periods I, II and III.....</b>   | <b>1</b>  |
| <b>1. Table of Contents.....</b>  | <b>2</b>  |
| 1.1.Preliminary Remarks on Period III:.....   | 5         |
| <b>2. Executive Summary.....</b>  | <b>5</b>  |
| 2.1.Background.....   | 5         |
| 2.2.The EU Project .....  | 6         |
| 2.3.The Technical Challenge.....  | 6         |
| 2.4.The Technical Solution .....  | 7         |
| 2.5.The Achievements of the Second Reporting Period PII .....   | 8         |
| 2.6.Achievements of Period PIII .....   | 9         |
| 2.7.Exploitation and Dissemination.....   | 10        |
| 2.8.The Patent.....   | 11        |
| 2.9.Summary .....   | 12        |
| 2.10.Outlook.....   | 13        |
| <b>3. Project Objectives and Major Achievements (LONMARK<br/>Deutschland e.V., J. W. Hertel).....</b>                           | <b>14</b> |
| 3.1.General Project Objectives.....   | 14        |
| 3.2.Objectives for the Second and Third Reporting period .....  | 15        |
| 3.3.Work Performed / Results .....  | 16        |
| 3.4.Contractors and Subcontractors.....   | 21        |
| 3.5.Main Achievements .....   | 23        |
| 3.5.1. Milestones .....   | 23        |
| 3.5.2. Deliverables (see also section 8, Appendix 2 – Plan for Using and<br>Dissemination of Knowledge).....                    | 23        |
| 3.5.3. Hardware and Software Design.....  | 28        |
| 3.5.4. Communication .....  | 29        |
| 3.6.Most Important Problems Encountered and Corrective Actions taken during PIII<br>(JH and MM/TPC) .....                       | 29        |
| 3.6.1. Knowledge .....  | 29        |
| 3.6.2. SAFETYLON protocol.....  | 30        |
| 3.6.3. Hardware- and Firmware Architecture (DL/Loytec).....   | 30        |
| 3.6.4. Safety Software and the Safety Operating System (SOS) (TN/TUW<br>ICT) .....  | 31        |
| 3.6.5. Installation and Commissioning concept (PF/MH of FH DO).....   | 32        |
| 3.7.Superiority of the 3-processor solution for the SMEs (CB/IBT).....  | 33        |
| 3.8.Partial merging of Deliverables D6, D7 and D8 (DL, TN).....   | 34        |
| <b>4. Work Packages Progress.....</b>   | <b>36</b> |
| 4.1.Work Package 1: Requirements, Specifications, Quality Assurance and<br>Certification (P. Wratil / M. Mentzel, Innotec)..... | 36        |
| 4.1.1. Objectives.....  | 36        |

|   |     |
|---|-----|
| 4.1.2. Results .....  | 37  |
| 4.2. Work Package 2: Development of Safety Chip (Thomas Novak, ICT).....  | 40  |
| 4.2.1. Objective .....  | 40  |
| 4.2.2. Results .....  | 40  |
| 4.2.3. Dissemination activities .....   | 42  |
| 4.3. Work Package 3: Development of Tools (P. Fischer/M.Mentzel, FH Dortmund)..   | 44  |
| 4.3.1. Objectives.....  | 44  |
| 4.3.2. Results .....  | 45  |
| 4.4. Work Package 4: Development of Interoperable Safety Modules .....  | 61  |
| 4.4.1. Objectives.....  | 61  |
| 4.4.2. Results .....  | 61  |
| 4.5. Work Package 5: Demonstration Applications (Ch. Brönnimann/IBT) .....  | 68  |
| 4.5.0. Objectives and Description of Work Packages WP 5.1 to WP 5.9 .....   | 68  |
| 4.5.1. WP 5.1 Emergency Lighting (IBT Ing.Büro Brönnimann, Thun,<br>Switzerland).....   | 69  |
| 4.5.2. WP 5.2 Elevator Control (INTRON GmbH & Co. KG, Germany)) .....   | 72  |
| 4.5.3. WP 5.3 Escape Route Management (IBT Ing.Büro Brönnimann,<br>Thun, Switzerland).....                                      | 74  |
| 4.5.4. WP 5.4 Fire detection and intrusion protection (ZDANIA Sp.z.o.o.,<br>Poland) .....                                       | 81  |
| 4.5.5. WP 5.5 Emergency Exit Button (Nodex AB, Sweden) .....  | 87  |
| 4.5.6. WP 5.6 Access control (Apice s.r.l., Italy).....   | 88  |
| 4.5.7. WP 5.7 Fault Indication and Switch Control Panels (Unitro<br>Fleischmann, Germany) .....                                 | 93  |
| 4.5.8. WP 5.8 SAFETYLON Network Management Tool (NEWRON<br>System, France) .....  | 95  |
| 4.5.9. WP 5.9 SAFETYLON Testbed.....  | 102 |
| 4.5.10. Summary and Results .....   | 103 |
| 4.6. Work Package 6: Exploitation and Dissemination (IAGs) .....  | 104 |
| 4.6.1. Exploitation .....   | 104 |
| 4.6.2. Dissemination (PK, AB, JH/MM contributions for their respective<br>territories) .....                                    | 112 |
| 4.6.3. Exploitation and Dissemination after the Project (PK, AB, JH/MM<br>contributions for their respective territories) ..... | 128 |
| 4.7. Work Package 7: Training (PLUG and IAGs) (PK, AB, JH/MM contributions for<br>their respective territories).....            | 132 |
| 4.7.1. PLUG activities in WP 7.....   | 137 |
| 4.7.2. Training environment.....  | 137 |
| 4.7.3. Training program and training handbooks.....   | 138 |
| 4.7.4. Trainings organized by PLUG .....  | 139 |
| 4.7.5. LMD Activities in WP 7 .....   | 141 |
| 4.7.6. LUS Activities in WP 7 .....   | 145 |
| 4.8. Work Package 8: Project Management (Jürgen Hertel, Martin Mentzel).....  | 147 |
| 4.8.1. Objectives.....  | 147 |
| 4.8.2. The Web based project management tool <i>Projectplace</i> .....  | 147 |
| 4.8.3. The DoW Project Plan .....   | 147 |
| 4.8.4. Deviation and Delays and Corrective Actions taken (J. Hertel, M.<br>Mentzel) .....                                       | 148 |
| 4.8.5. Communication with contractors (JH, MM).....   | 148 |
| 4.8.6. Financial and Administrative Management (JH) .....   | 149 |
| 4.8.7. Milestones and Expected Results (JH) .....   | 150 |

---

|           |   |            |
|-----------|---|------------|
| <b>5.</b> | <b>Consortium Management (J.Hertel, LONMARK Deutschland e.V.)...</b>                                | <b>152</b> |
| <b>6.</b> | <b>Other Issues .....</b>   | <b>154</b> |
| 6.1.      | Contributions of the Industrial Associations/Groupings (J.Hertel) .....                             | 154        |
| 6.2.      | Contributions of the RTD Performers (M. Mentzel) .....  | 154        |
| 6.3.      | Contribution of the SME Core Group (Ch. Brönnimann).....  | 155        |
| <b>7.</b> | <b>Appendix 1: Plan for Using and Disseminating the Knowledge .....</b>                             | <b>157</b> |
| 7.1.      | Exploitation of Knowledge.....  | 157        |
| 7.1.1.    | Exploitable Knowledge and its Use.....  | 157        |
| 7.1.2.    | Clarification of IPR issues (last column of Table A1.1).....  | 160        |
| 7.2.      | Dissemination of Knowledge .....  | 160        |
| 7.3.      | Publishable Results Acvtivities .....   | 162        |
| <b>8.</b> | <b>Appendix 2 – Actuals data of Deliverables in PIII.....</b>                                       | <b>164</b> |
| 8.1.      | Table 8.0 - 1: Updated List of Deliverables D1 to D14 (see DoW V2.0) for PIII                       | 165        |
| 8.2.      | Table 8.0 – 2: Updated List of Deliverables D15 to D30 (see DoW V 2.0) for PIII                     | 166        |
| 8.3.      | Table 8.0 - 3: Actually Achieved Milestones from DoW V 2.0 (Gantt chart)) during PIII .....         | 167        |
| 8.4.      | Table 8.0 – 4 Gantt chart of achieved WP Milestones in the SAFETYLON project (M. Mentzel ,TPC)..... | 168        |

## 1.1. Preliminary Remarks on Period III:

For reasons of convenience for the reader this report is an updated version of the Activity Report for Period I and Period II:

1. **Text of the PI report is in black color**
2. **Text of the PII report is in grey color**
3. **Text of the PIII report is in bright blue color**
4. Corrections, updates and whole new sections are marked in blue color
5. Small or insignificant editorial changes are not marked
6. Sections that are no longer relevant for Period III have been deleted entirely
7. Sections which relate to management information and which are covered in the Management Report for Period III have been omitted
8. Names behind the headlines indicate the main contributor(s) for that section, typically the person responsible for the content and result(s)

In this way the reader finds the familiar structure as in the Period I and Period II report and can readily identify the changes and additions which happened in Period II and Period III.

## 2. Executive Summary

### 2.1. Background

Open Systems have been in favour by many customer for many years now, and there is still no end to it. The advantages are obvious: vendor independence, freedom of choice, affordable, low cost solutions. Many of us think of computers and the IT industry as the only field where open systems can be applied. But since the late 90s the trend has also infected the controls industry. Most of all, CAN from Bosch and LONWORKS from Echelon (better known as LON) have revolutionized the automotive, machinery and the building automation industries. The secret: standardized communication protocols which were either available as portable source code or as embedded firmware in an application chip.

The protocols were only the beginning. Affordable tools, application profiles, network infrastructure products, and a plethora of application devices which followed soon are testimony to the market acceptance and success of this new market approach.

LON in particular has penetrated the global building automation markets, and until today, has won a sizeable market share over proprietary systems. For small and medium sized companies (SMEs) the investment in basic technology is relatively small so LON opened up many new opportunities for this group for virtually all functions and applications in commercial and public buildings. The only exception: applications where single or groups of persons may be endangered are subject to special standards and regulations. The pertinent global standard for safety related systems and applications is IEC 61508 which by now supersedes most national standards.

IEC 61508 does not only concern the communication protocol but all aspects of the “lifetime” of safe products or systems. When in early 2004 a Task Group of the project member LONMARK Germany (LMD) started to assess the size of the task to “upgrade” to a safe version in compliance with IEC 61508 it became very quickly clear that it was way beyond the financial means and the resources of the German user organisation.

---

The project SAFETYLON has been completed at the end of the extended Period III (May 22, 2008) with all objectives and Deliverables set in the DoW – and updated in the DoW V2.0 - achieved as planned. The cooperation between the SMEs, RTDs, and IAGs has worked very well due to the many operative meetings held primarily at the University of Vienna and due to the well organized management of the project. The decentralized organisation and its bodies, Project Management Committee (PMC), Technical Project Coordinator (TPC) as well as the Consortium Administrator (CA) and, last but not least, the Consortium Manager (CM) have all played their roles as expected and with dedication to the joint project.

The technical results have been documented very well and are now the basis of further exploitation and a licensing scheme after the project.

## **2.2. The EU Project**

In early 2005 we learned about the FP6 Collective Research Program. It was evident that it was a perfect fit for the situation in the LON community in Europe: many LON User Organisations (IAGs), sizeable number of universities and research oriented Engineering companies (RTDs) and hundreds of small and medium sized product companies and service providers (SMEs). In less than one month we assembled a consortium of 17 research institutions and companies from all over Europe (Italy, France, Switzerland, Germany, Poland, Sweden). As the financially strongest organisation LONMARK Deutschland e.V. took the leadership role. The project under the name of SAFETYLON passed all qualifying reviews and the funding was awarded September 2005. The first consortium meeting took place in Berlin on May 24, 2005. The Consortium Agreement was negotiated and signed in a record time of less than 2 months.

In Period III the Project Management Committee (PMC) decided to devote more resources and funding towards the development of the Safety Operating Software (SOS) because the effort, time and funding had been significantly underestimated. Also, the PMC account which had been established to finance joint costs of the Consortium, e.g. meeting costs, costs for the Technical Project Coordinator, costs of electronic components for building the SME development kits, TÜV Nord training costs of Consortium members in IEC 61508, non-budgeted excessive costs by TÜV Rheinland for the final assessment process. Therefore it was required to reflect all these changes in an updated DoW V2.0 including an updated budget.

## **2.3. The Technical Challenge**

In order to design an open and interoperable protocol based on the ANSI EIA 709.1 or EN14908 protocol (LON) which is compliant with the Safety Integrity Level SIL3 of EN61508 (e.g. many people in a large public building like an airport) a number of challenges have to be fulfilled in order to assure a high degree of backward compatibility. Safe and non-safe communication must operate simultaneously in one physical network, i.e. the channel infrastructure of a standard LON network including standard routers and Ethernet routers (EIA 852 standard) must not be changed. Open systems typically offer multiple hardware platforms, i.e. in the case of SAFETYLON at least one second source of core hardware is required. However, the application software must be identical in order to assure portability of applications. Further, the interoperability with regard to the LONMARK framework must be

---

assured. And finally, the installation method must be familiar and proven, and must be based on the procedures of standard LON.

The SAFETYLON project turned out to be much more complex than anticipated due to many factors, most of them of technical nature. The original idea to base the development on a commercial embedded operating system had to be ruled out due to tough certification requirements by TÜV (documented source code developed in accordance with IEC 61508).. Therefore the operating system (Safety Operating Software SOS) for our exemplary safe hardware design had to be designed and developed from scratch. Some of the anticipated risks were in fact encountered but could be overcome by decisions which confined the parameters of execution.

## **2.4. The Technical Solution**

In the DoW the preferred solution was a dual processor architecture whereby one processor was one of the standard LON chips (Neuron or NEC LC30x0) serving as communication and application processor, and the secondary, different chip was to perform the role of a redundant processor. Both chips were to check each others sanity and results. After in-depth research and calculations it became clear that we needed a much more powerful architecture because of the permanent self-testing of hardware and firmware and the bandwidth required for interprocessor and I/O communication. The final design specification is characterized by the following features:

- a two channel design for the SAFETYLON protocol based on a duplication of safety frames within a single EN14908 frame
- an application layer protocol which provides a set of “safe” services in a “safety layer”, independent of the underlying standard LON protocol
- a dual safety processor architecture communicating through either a front-end LON chip from Echelon or from Loytec
- a simple safety scheduler of own design and implementation in order to avoid the complexity and the cost of using a commercial embedded operating system
- two functionally identical core modules from two Industrial RTDs (WHO and Loytec) to provide a ready to use platform for SME applications
- choice of either a commercial or a public domain application development environment which will increase the acceptance and ease of use for SMEs
- employing an enhanced version of available commercial tools in combination with a verification method of safe installation parameters

The new three processor architecture is decidedly more powerful and in many ways superior to the DoW proposed design. In particular, the SME safety applications will now be identical for both hardware platforms and even the safety firmware will be identical. It turned out, however, that the implementation will require significantly more time and resources than originally planned. This concerns primarily the three RTDs who are responsible for the design and development of the core functionality, i.e. Innotec, ICT and FH Dortmund. In order to compensate for these unplanned efforts the entire work plan was reworked and some critical paths could be eliminated. To be on the safe side, though, it may occur that the project end date may have to be extended by up to three months.

---

## 2.5. The Achievements of the Second Reporting Period PII

As described in the Activity Report for the First reporting Period the time schedule of the project is delayed by three to six months depending of the work package or sub-workpackage. On the positive side, however, it can be stated that the technical solution based on a three processor solution with two identical safety chips is a significant improvement over the architecture proposed in the DoW V1.0. In particular, the new architecture supports an identical software architecture for the safety core modules based on the Neuron FT3120 chip and the Loytec LC 3020 chip, which guarantees a true second source for the core modules. Another positive effect is the fact that the fees for type approval and certification of both core modules, which depend heavily on the software, can be limited to max. 60 k€ which would otherwise be double that amount.

The achievements can be summarized as follows:

- the “SAFETYLON concept” has been approved by TÜV Rheinland (WP1)
- The final patent has been filed with the European patent office (Deliverable D3) in April, 2007 (WP 6.1)
- the software / firmware of the safety chips 70 % completed (WP2) completed
- the tools software / firmware of interoperability and installation 70% completed (WP3) completed
- testing environment for black box testing (based on a commercial product Labview from National Instruments) is established and ready to start testing (WP 3.3) completed
- the hardware of the two core modules completed (WP 4)
- the hardware of the main (mother) board and the I/O hardware completed (WP 4)
- in two workshops SME’s receive training on safety application development and receive their own development kit from the RTDs (WP5)
- the IAGs complete (or 80% complete) important Deliverables of exploitation (final patent, Joint Ownership Agreement, SAFETYLON License Agreement) (WP6.1) completed
- the IAGs perform important activities regarding their dissemination obligations (presentations, participation in tradeshows, development of a website) (WP6.2) completed
- The IAGs perform first activities regarding training (organisation of two SME workshops, provision of training kits for SMEs, planning of training) (WP7) completed
- The management team consisting out of the Consortium Manager (CM), the Technical Project Coordinator (TPC) holds the consortium together by planning organizing and executing the following meetings: (WP8, WP7, WP1.3)
  - Consortium Meeting (1) one
  - PMC Meetings: (6)
  - RTD Meetings: (6)
  - IAG Meetings: (7)
  - SME workshops (2)

---

## 2.6. Achievements of Period PIII

As described in the Activity Report for the Second reporting Period the time schedule of the project had to be further extended by six months due to the fact that the development of the Safety Operating Software (SOS) by ICT proved to be a very challenging task and highly demanding on the ICT resources. This fact had been recognized as early as the beginning of 2007 which had led to additional funding of ICT, significant re-budgeting and the submission of a new DoW V2.0 which was accepted in its final version by the EC in January 2008.

Although all functions and modules of the SOS software could be completed within the extended final period, the parallel and subsequent testing as well as the quality assurance work in Vienna, Krakow and at Innotec uncovered a number of areas that still require further testing and optimization of the code. This situation has not only been foreseen in the risk assessment of the original DoW but has also been reiterated as Risk (4) in DoW V2.0.

A special Review Team established by the PMC and led by Innotec came to the conclusion in November 2007 that while both core modules are well suited as a generic basis for SAFETYLON prototype development additional functional, performance and stability tests must be performed in order to achieve a TÜV type approval of “real life” SAFETYLON products. For the RTD and SME prototype developments the Review Team recommended to use the core modules including the SOS as a suitable framework while performing the additional tests and improvements when developing final SAFETYLON products. This finding essentially coincides with the results of the analysis of the assessment and certification work which has been performed by TÜV Rheinland, Cologne during the months of April and May 2008.

Therefore the PMC decided in its December 2007 meeting – which was held jointly with the IAG panel – to modify the certification / type approval procedure as specified in the DoW V 2.0 and rather request an assessment of Consortium development work and results by TÜV Rheinland according to IEC EN 61508, SIL 3 requirements. The modified objective: analyze, qualify and certify the fitness of the SAFETYLON hardware and software development in conjunction with the IEC 61508 procedures for adaptation to “real life” SAFETYLON products (see Deliverable D26). Aside from realizing that this approach is much more meaningful within and beyond the SAFETYLON project it also had the advantage to be less expensive than a full type approval (33.5 k€ instead of approx. 60 k€).

- results of RTDs:     HW: core modules, prototyping PCB, IO-PCB; Test bed, Training Kits  
                          SW: SOS, Tools-Suite, Testing Suite, Test bed
- results of SMEs: 5 / 8 prototypes completed; description of prototype
- 
- results of IAGs: seminars in 3 regions; Training workshops in 3 regions; participation in tradeshows, LMD press conference; JOA, License Agreement;
- Results of Management: DoW V2.0, TCRS V 2.3, final Consortium meeting; PIII report: review of Form C reporting;

## **2.7. Exploitation and Dissemination**

The terms of cooperation including rights and obligations of each partner have been summarized in a Joint Ownership Agreement to be signed by all three IAGs. The terms of licensing will be covered by a European SAFETYLON Licensing Agreement which specifies three types of licenses and which will be the basis of all commercial activities. A cooperative model has been chosen which encourages the cooperation across regional boundaries and also with other European User Organisations which are currently not participating in the project. The spectrum of dissemination activities will be broad and range from publications, press releases, presentations, seminars / workshops, tradeshows / exhibitions to proactive selling (see D3). Aside from the IPR which will be protected by a patent there are many other, non-patentable aspects of exploitable knowledge resulting from the work in the consortium. Examples are the extension to other LON channels like Powerline, RS485 and RF and the adaptation of other existing commercial tools to support SAFETYLON.

The immediate objective of selling licenses is to recover the co-financing by the IAG organisations which, in the case of LONMARK Germany, is in excess of 100,000 €. Beyond that break-even point it is expected to generate an ongoing revenue stream in order to continue the development work (error and feature updates), as well as to provide support to existing and new customers. Most important, though, is the objective of winning as many as possible new customers among the members of the European user organisations for SAFETYLON, and, winning new members through SAFETYLON.

During Period III the negotiations of the IAGs regarding the two major Agreements for Dissemination of the SAFETYLON technology, the Joint Ownership Agreement (JOA) and the SAFETYLON License Agreement (SLA), were finalized. Both agreements are submitted under the Deliverable D16. The JOA was signed recently: it reflects the original idea of the three European regions or territories CENTRAL, NORTH and EAST as defined in the DoW V2.0 and the assignment of responsibilities to these regions. It further establishes a Joint Ownership Executive Committee (JOEC), staffed by one member from each IAG, which will essentially replace the IAG panel after the project. In this way a “continuation” of the project is maintained. For the time being the SLA is available as a special license for Beta customers; it can be easily adapted to a full commercial license once the Beta program runs out by the end of 2009. Both agreement have been developed with the help of a lawyer with experience in European law (Law firm Samson & Partner, Munich) The current version of the SLA is also part of Deliverable D16. More details in chapter 4.6.

Regarding dissemination a series of seminars and training workshop were held in all three regions. Despite of an enormous recruiting effort address material by the IAG central offices, in particular TEMA, the agency of LONMARK Germany, the number of participants per seminar was below our expectations and numbers stated in the DoW V2.0, except for Poland which scored much better. One reason, of course, was that in 2006 and 2007 we had already informed the LONMARK members and “insiders” about SAFETYLON on various occasions like General Assemblies, Task Group meetings and tradeshows. Another reason which pertains to external prospects may be, that LON is still unknown to many people in the safety community. We expect that this is going to change in the near future.

One such event worth mentioning here was the SAFETYLON booth on Light & Building 2008 in Frankfurt /M. – prior to the announced seminars and training workshops. It was well

---

attended and many interested visitors were given individual tutorials and training sessions. In context with the tradeshow LONMARK Germany held a press conference attended by about 30 trade journalists. The results are part of Deliverable D16 because the presentation and press material is forward looking and addresses the time after the project.

Another such event was the joint presentation of the TPC and the CM in front of the General Assembly Meeting 2008 of the LONMARK Deutschland e.V. (LMD). In this presentation the emphasis was less on the SAFETYLON technology but rather on the results of the project (summary of deliverables ) and a detailed comparison between SAFETYLON and other safety technologies in the market.

In order to assure the continuation of work after the project two groups have been established:

- a special Task Group SAFETYLON under the umbrella of the LMD “Arbeitskreis Technik” which is headed by Martin Mentzel, the TPC of the SAFETYLON project
- an international group JOEC (see above) with one member of each IAG which manages the ongoing “technology exchange” as well as licensing matters and continued cooperation regarding SAFETYLON. This group will probably be headed by Martin Mentzel as well.

Finally, but most important, of course, as a result of the efforts in tradeshow, seminars and workshops a number of seriously interested “prospects” have been visited on their sites for individual consultation and know-how transfer for commercial safety products and projects. In Germany these are the companies TROX, MST and Dräger. The objective is, of course, to win these companies as Beta customers.

## **2.8 The Patent**

In the DoW it was proposed to file a patent on SAFETYLON in order to better protect the generated IPR. A patent group was established led by the Consortium Manager to enter into a dialogue with the Munich patent firm Samson & Partner. The objective of our patent strategy was defined as

- to protect knowledge developed in the project and to cover our specific implementation
- to claim unique features and capabilities which are characteristic for SAFETYLON but cannot be found in other safety systems today
- create the basis for further exploitation after the project

Since safety technologies have enjoyed a strong attention and investment by large firms e.g. Rockwell and Siemens, or User organisations like CAN in Automation (CiA) a number of fundamental techniques like the duplication of data in a single frame have already been filed for patent. Therefore the SAFETYLON patent concentrates on the particular aspects that are unique for LON, i.e.

- the safe multicast addressing (important for large networks like LON)
- the replication of at least one, all or additional ISO/OSI services of the underlying communication protocol in the SAFETYLON safety layer
- the concept of a safe scenario which can be executed over a period of time involving the action of hundreds of safe or non-safe devices (concept of a “controlled shutdown”)

- 
- an innovative installation and commissioning method
  - all technical aspects that have to do with interoperability and conformance to an open standard

The final patent has been filed on April 23, 2007. Until today we have received no feedback from the European Patent office. The IAG partners have been made aware of this fact, but will probably decide not to make use of it at the moment (primarily for financial reasons).

The value of the patent is that it forms the basis for the SLA License Agreement and the commercial engagement of the Consortium members with companies in their respective territories and in the entire Europe. A prospect customer of SAFETYLON can evaluate the intellectual content behind the technical details and deliverables as documented in ANNEX II of the SLA and therefore gets a very good idea about the amount of work and the complexity of the development environment which the joint consortium effort has created

## **2.9. Summary**

The predominant modification introduced to the DoW is the merging of two alternative 2-processor architectures with two different microcontrollers (Neuron and LC3020 based) into a single coherent architecture with three microcontrollers (where the third is a Neuron FT3120 or LC3020 as a communication front end). This means that the safety hardware/firmware and application programs become identical for both versions. Moreover, with this extended architecture more safety applications can be addressed and therefore the market approach is much broader which generates advantages for the SMEs within and outside the project. It also enables the [evaluation and qualification of the architecture and source code](#) of the unified Safety Operating System (SOS) by TÜV Rheinland which is a prerequisite for an affordable certification of SME products. From the SME's perspective the new solution provides a definite advantage because it is less difficult to handle.

All work and deliverables as specified in the DoW V2.0 have been successfully completed. Due to the delays in WP 2 and the extension of the project by 6 months even all SME prototype developments could be finished in time. The only "deviation" from the DoW V2.0 specifications was initiated by the decision jointly taken by the PMC, the IAG panel, the TPC and the CM in December 2007 to modify the scope of the Deliverable D26 from a TÜV type approval / certification of the SAFETYLON core modules to an assessment of work and a qualified official statement about the completeness, quality and "market readiness" of the project results .

This decision actually has turned out to be a pragmatic move as well as a much less costly exercise in view of the migration of the consortium results to "real life" safety products and safety projects. The main reasons are:

- the form factor as well as the number and type of hardware IOs of most safety products will require a redesign of the hardware and subsequently slight modifications in the drivers of the SOS software.
- a full type approval / certification process as typically carried out by TÜV for commercial product would be of limited value and also more than twice to three times as expensive which was a serious concern to the PMC given the already exhausted funding.

- 
- for the purpose of developing new products the prototyping hardware and the SOS source code as well as the development and installation tools are fully sufficient and functional without any type approval
  - any type approval and certification process requires detailed documented information about the company and the Functional Safety Management processes of the developing and manufacturing company. Such process would have been totally beyond the means and resources of the consortium, even though it might have been limited to the 6 RTDs only.

## 2.10. Outlook

Now, that the Safety concept has been approved and the SAFETYLON hardware completed more than half of the job is done. However, there are still many challenges ahead which will require more time – and probably hours / money – than had been anticipated and planned. In order to assure the continuation of the work on WP2 the three IAGs jointly have to fund the development team of ICT with an amount of 50 k€. Moreover, the higher than planned effort of type approval / certification will require additional 30 k€ “contribution” from the three IAGs.

The major tasks ahead for Period III are:

- completion of the (already tested !) safety chip software by ICT (10/2007)
- completion of white box testing (ICT) and black box testing of the safety chip software (AGH-UST) (11/2007)
- completion of the first prototype applications: emergency push-button, logic element, (09/2007) fire damper, emergency lighting (02/2008)
- establishing the core SME group as a “team” to generate their prototype applications in identical quality (challenge for team leader Chris Brönnimann)
- completion of all functional safety documentation by the RTDs in order to support Innotec with the type approval / certification process by TÜV Rheinland.
- establishing two identical test beds at FHDortmund and AGH-UST Krakow and successfully test the SME demonstrator prototypes in a small SAFETYLON network partially done (Note: this goes beyond the requirements of the DoW but is deemed necessary in order to assure replicable testing results)
- complete all documentation as Deliverables of DoW 2.0 and as part of the Deliverables of the SAFETYLON License Agreement (SLA)
- completion of all functional safety documentation by the RTDs in order to support Innotec with the type approval / certification process together with TÜV Rheinland
- establishing two identical test beds at FHDortmund and AGH-UST Krakow and successfully test the SME demonstrator prototypes in a small SAFETYLON network partially done (Note: this goes beyond the requirements of the DoW but is deemed necessary in order to assure replicable testing results)
- complete all documentation as Deliverables of DoW 2.0 and as part of the Deliverables of the SAFETYLON License Agreement (SLA)

### **3. Project Objectives and Major Achievements (LONMARK Deutschland e.V., J. W. Hertel)**

#### **3.1. General Project Objectives**

The overall objective of the project is to develop a concept and an *open, interoperable, economical and high performant* solution for the market demand for safety networks based on the LON technology which are compliant with the European and International safety standard EN/IEC 61508, up to the Safety Integrity Level 3 (SIL3). Such compliance needs to be verified, approved and certified by the respective authorities. In our case we selected TÜV Rheinland as one of the highly recognized European authorities for safety related systems. While the properties *economical and high performant* can be called state-of-the-art there are particular challenges to fulfil the objectives *open and interoperable* as the well known “trademarks” of LON in the marketplace.

The main three technical objectives of WP1 to WP5 are:

- to develop the best of its kind, state-of-the-art hardware and software platform for SAFETYLON which combines high performance at the lowest possible cost
- to build eight to ten different prototype device types, specified and designed by experienced SMEs, each in its own special field, suited for various safety applications in building automation, thereby testing the results of the project and the developed technology
- to design and implement an innovative installation and device commissioning method and test the proper interworking of the prototype devices in a realistic test bed

The main five non-technical (or commercial) objectives are:

- secure the intellectual property created by the RTDs by filing a European patent (including the option to expand its reach to other continents) (WP6, D3)
- ascertain a fair, efficient cooperation and sharing of the IPR between the three IAGs by creating and signing a Joint Ownership Agreement and apply a common License Agreement (WP6)
- prepare and launch a European wide exploitation and dissemination program carried out by three IAGs (LON User Organisations) (WP6, D4)
- develop and launch a European wide high quality training program for both the members of the LON User Organisations and new projects (WP7)
- secure the ongoing development by follow on projects, either within FP7 or within local R&D programs (WP8)

### **3.2. Objectives for the Second and Third Reporting period**

Aside from meeting the (revised) plan of the beginning of Period II the consortium had to meet some hard objectives in order to continue work. These are

- The approval of the SAFETYLON concept by TÜV Rheinland (achieved on September 15, 2006)
- The filing of the final patent (achieved on May 23, 2007)
- Progressing with the Deliverables of Period II as far as possible
- Improved cost and time reporting / control / management by introducing the Time and Cost Reporting Sheet TCRS Version 2.1
- Establishing Functional Safety Management at the RTDs in preparation of the type approval / certification process in period III
- Training of non-German speaking partners in IEC61508
- Improved communication with EC

In order to achieve these goals with a group as spread out and diverse as the SAFETYLON consortium the means and tools for a productive and effective collaboration were further developed. In particular, the awareness for the reporting obligations of each member regarding activities and financial performance were strengthened.

The major tasks for Period III are:

- completion of the (already tested !) safety chip software by ICT (10/2007)
- completion of white box testing (ICT) and black box testing of the safety chip software (AGH-UST) (11/2007) done
- completion of the first prototype applications: emergency push-button, logic element, (09/2007) fire damper, emergency lighting (02/2008) done
- establishing the core SME group as a “team” to generate their prototype applications in identical quality (challenge for team leader Chris Brönnimann) partially done
- completion of all functional safety documentation by the RTDs in order to support Innotec with the type approval / certification process together with TÜV Rheinland done ???
- establishing two identical test beds at FHDortmund and AGH-UST Krakow and successfully test the SME demonstrator prototypes in a small SAFETYLON network partially done (Note: this goes beyond the requirements of the DoW but is deemed necessary in order to assure replicable testing results)
- complete all documentation as Deliverables of DoW 2.0 and as part of the Deliverables of the SAFETYLON License Agreement (SLA) done ?

The following tasks planned for PIII were in fact completed:

- development of safety chip software by ICT (12/2007)
- white box testing (ICT) and black box testing of the safety chip software (AGH-UST) (03/2008)
- all prototype applications: emergency push-button, logic element, (09/2007) fire damper, emergency lighting (04/2008)
- establishing the core SME group as a “team” to generate their prototype applications in similar quality applying the same methodology (challenge for team leader Chris Brönnimann)

- 
- all functional safety documentation by the RTDs in order to support Innotec with the assessment / certification process by TÜV Rheinland.
  - two identical test beds at FH Dortmund and AGH-UST Krakow and successfully test the SME demonstrator prototypes in a small SAFETYLON network partially done (Note: this goes beyond the requirements of the DoW but is deemed necessary in order to assure replicable testing results)
  - reviewing and finalize all documentation as Deliverables of DoW 2.0 and as part of the Deliverables of the SAFETYLON License Agreement (SLA)
  - all functional safety documentation by the RTDs in order to support Innotec with the type approval / certification process together with TÜV Rheinland.
  - two identical test beds at FH Dortmund and AGH-UST Krakow and exemplary testing of the SME demonstrator prototypes in a small SAFETYLON network

In the final months of the project all members were finishing their work packages and were already preparing their Deliverables. However, after May 23, 2008 several members, especially SMEs still needed time to complete their Deliverables and other reporting contributions. The LMD management team has been very busy in the previous months to remind the members of their reporting obligations and repeatedly review / correct the reporting results.

### **3.3. Work Performed / Results**

The work performed will be covered in the detailed reports of the work package leaders in chapter 4. Since both the Consortium Manager or the Technical Project Coordinator are closely involved in the work of the contractors it can be said today that the work is performed to high standards and that all teams are very motivated to cooperate and to communicate their results in a timely manner.

Having said this the overall project plan had to be revised in order to accommodate the delays of 3 to 4 months, particularly in WP1 to WP3, 2 months in WP4. The reasons for this delay are twofold:

- (1) the PMC set the starting point of the project “back” to May 23, 2005 because the first preparatory Consortium meeting was held in Berlin on May 24, 2005 although the final contract was only finally awarded on September 13, 2005. The reasons were, of course, that every participant could charge his or her cost to the project, and secondly, that there would be no problems with pre-existing know-how, since many ideas about the concept and the implementation had already been conveyed to and discussed with the contractors in Berlin. The official SAFETYLON project kick-off meeting took then place about one month later in Krakow on June 30, 2006 in the presence of Cathy Pouret, our F&A officer of the Commission. With hindsight, it would have been better to set the starting date to September 1, 2005 which would have avoided the delay.
- (2) the education of the consortium members with regard to safety and the changes from a 2-processor to a three 3-processor architecture required considerable analytical work and communication effort in order to minimise the risk and the development cost of the new approach.

The work items which are 100% completed are

- 
- the Safety Requirement and Technical Specification for SAFETYLON including the Safety Life Cycle document (WP1, WP3)
  - the acceptance of these specifications by TÜV Rheinland, which was an important milestone and provides a official “proof of concept” certificate (WP1, WP3). This is, aside from the patent, the most important item of IPR.
  - the specifications for the development of the Safety chip, which now includes the 3-processor architecture (based on the popular ARM7 core), the embedded Safety Operating System (SOS) or scheduler as well as the safety layer (SL) with the safety protocol services (WP2)
  - the specifications for the Development of interoperable Safety modules in two variants (Neuron FT3120 and Loytec LC3020 based) . In addition, a new reference design for a universal prototyping I/O board has been specified which will allow SMEs to start their prototype developments much earlier than originally planned
  - the Safety Application specifications for 7 SME prototype devices (WP5, D2)
  - The final patent document (WP6.1). A preliminary patent had been filed on April 21, 2006 at the European Patent Office in order to secure the filing date one day before the first presentation of SAFETYLON on two tradeshows in Germany
  - A plan for exploitation of the IPR during the course of this project (WP 6.1)
  - A plan for the dissemination of the knowledge during the course of the project (WP 6.2)

and, completed in Period PII:

- the development of the core modules both for the Neuron FT3120 and the Loytec LC3120 chip (hardware)
- the development of the mainboard (motherboard) into which either of the core modules can be plugged
- the development of the I/O board which can be attached to the main board
- the (small volume) production of the three PCBs, i.e fully functional prototype hardware

Among many detailed results and documented progress in Period II here is a list of the “hard” results which are either Deliverables in itself or are part of Deliverables for period II reporting or content of the SAFETYLON License Agreement (SLA). The results are ranked in accordance to their importance for the SAFETYLON project:

- The concept approval of TÜV Rheinland has been successfully completed (09/2006)
- The final patent was filed with enhanced claims and improved content (05/2007)
- The awareness and methods for a functional safety management in accordance with IEC 61508 has been established with the RTD performers and is being introduced at the SMEs
- All specification documents were reviewed updated and completed to reflect the latest state of development
- The SME developers kits have been completed and tested, consisting of
  - Neuron FT31 and LC3020 core modules
  - The main board or motherboard
  - The I/O interface module
  - An initial release of the safety software and associated demonstrator applications
  - An initial release of PC installation tools / environment (FH Dortmund, WHO)
  - An initial release of the development tool chain (KEIL)

- 
- SME workshop and knowledge transfer (with RTDs) incl. delivery of hardware and software
  - An English language training class on the 61508 standard and related developing and testing methods was given by TÜV Nord, Augsburg for the SMEs and one RTDs
  - Analysis of effort / costs of safety software and type approval : independent quotations were obtained of TÜV Rheinland, Cologne and of TÜV Nord, Augsburg)
  - Establishment of a Safety Lon LONMARK Task Group (11/2006)
  - Analysis and decisions regarding the separation of white box testing (performed at ICT, reviewed by a review team), and black box testing (performed by AGH-UST), and integration and system testing (performed by ICT and AGH-UST)
  - Drafting and reaching agreement of the three IAGs on the Joint Ownership Agreement (JOA) and the SAFETYLON License Agreement (SLA)
  - Development of a SAFETYLON Website (by subcontracting a small, highly specialized Multimedia company 'aimcom' in Munich)
  - Participating in several Tradeshows: Hi-Tech House Moscow 2006, HMI 2007 in Hanover, Germany,
  - preparation of presenting SAFETYLON on the INDIN 2007 conference: 5 presentations, 1 Tutorial
  - Replanning of period III budget in several iterations in the PMC and IAG panel in order to reflect the financial decision taken to stay "operational" during period III
  - New major release TCRS V2.1 of our Time & Cost planning, recording and reporting tool which generates Form C information (developed by the CM because of lack of available electronic tools from EC)

It is also noteworthy to report on several major decisions of the PMC which resulted in a financial agreements between the three IAGs and a rearrangement of the financial plan of the consortium:

- the three IAGs will pay 50 k€ (Financial Contribution) for the extended work of TUW\_ICT of approx. 12 person months
- the work of CANDELUX shall be performed by IBT in addition to their existing development at a reduced budget of 18 k€ (benefit: emergency lighting will be covered within the project);
- the PMC budget which is managed by the Consortium Manager will be upgraded from 80 k€ (i.e. 4% of total FC volume) to 150 k€ (7.5%). This upgrade is primarily funded by the five RTDs (except ICT) and by the three IAGs
- the Technical Project Coordinator (TPC) will be fully paid from the PMC budget (approx. 60 k€ over the 36 months period), instead from the LMD budget
- further, the costs for the production of the hardware kits for the SMEs (2 per SME) and for the training kits, will be refunded by the PMC (approx. 30 k€)
- subcontracting of costs for exploitation and dissemination which benefit all three IAGs will be shared in proportion to their FC budgets
- the PMC agreed to a proposal by Innotec to carry out the entire assessment process regarding the two core modules including SOS safety software with TÜV Rheinland in its own responsibility without additional funding. This offer is provisional of the EC accepting that the approval may be given AFTER the end of the project, but before December 31, 2008

- 
- the development of the core modules both for the Neuron FT3120 and the Loytec LC3120 chip (hardware)
  - the development of the mainboard (motherboard) into which either of the core modules can be plugged
  - the development of the I/O board which can be attached to the main board
  - the (small volume) production of the three PCBs, i.e fully functional prototype hardware

The achievements and results of Period III are summarized as follows:

- the complex situation arising from the delays and increased development efforts of ICT for the Safety Operating Software (SOS) was managed successfully by the PMC, TPC and the CM by negotiating the changes with all Consortium partners and the Scientific and Financial officers, as well as documenting the results in an updated DoW version 2.0 including a recalculation of the entire budget.
- subsequently, the project duration was extended from 30 months to 36 months allowing, in particular, the completion and testing of the SOS as well as the completion and testing of SME prototype applications
- the software / firmware of the safety chips (SOS) is now successfully completed (WP2, Deliverable D8). This means that the R&D work of all RTD performers has been 100% fulfilled in compliance with the DoW V2.0
- A RTD review group was established to monitor and supervise the development of the Safety Operating Software (SOS) developed by ICT. The group finished their task in December 2007 and came to the conclusion that the Software is complete with regard to all specified functionalities and ready to build all SME prototype applications successfully.
- the tools software / firmware of interoperability and installation are now 100% completed (WP3, Deliverables D9 and D10)
- the testing environment for black box testing (based on a commercial product Labview from National Instruments) is now fully established at AGH-UST in Krakow and all specified tests (WP 3.3) have been carried out and documented extensively (Deliverable D12). This professional testing environment also allowed for frequent retesting under slightly changed conditions and also a quick turnaround and response to new versions of the SOS software.
- an identical testing environment based on Labview has been set up at FH Do in order to have an independent testing facility specializing on a testbed for system testing of two or more intercommunicating SAFETYLON products (WP5.9, Deliverables D12 and D25)
- As part of the Quality Assurance task (WP1) the RTDs put a review team in place which was staffed by at least one member of each RTD. All generated documentation was thoroughly reviewed and the reviewed and qualified documents were compiled in a document (Annex II, which is now part of the Licensing Agreement)

- 
- the “assessment” of the entire SAFETYLON development has been performed by Innotec and TÜV Rheinland (WP1, Deliverable D26) with contributions from all other RTD performers. This activity was complemented by thorough documentation review in which all RTDs participated, as well as by the SOS review team led by the Technical Project Coordinator
  - the RTDs who Ingenieurgesellschaft and Loytec GmbH developed very proficient and very well documented sample applications (“Emergency Push Button” and “Logic Element”) which proved very helpful for the SMEs in developing their own prototyping applications
  - the SME group, led by Chris Brönnimann of IBT, gathered in a number of specification review and implementation workshops with the participating SMEs in order to promote and teach the FSM-methodology of IEC 61508 as well as the proper use of the design and SW engineering tools. Consequently, all SMEs were enabled to complete their prototypes (WP 5.1 to WP 5.9, Deliverables D17 to D24)
  - the IAGs continued to work on various fronts of SAFETYLON exploitation and completed a number of documents and Deliverables of WP 6.1 (final patent, modular presentations, Joint Ownership Agreement, SAFETYLON License Agreement, and, last but not least, the Plan for Exploitation of IPR after the project (Deliverable D16)
  - the IAGs continued to work on various fronts of SAFETYLON dissemination of WP 6.2 (presentations, participation in tradeshows, development of a website, series of seminars conducted in all three regions, a press conference, and several publications)
  - the IAGs, in particular PLUG in close cooperation with ZDANIA, completed the development of the training kit “in the box” and the associated training material. LMD and LUS have been using this material in a series of training workshops (WP7, Deliverables D28 / D29). The training kits were also used for demonstrations and individual trainings on tradeshows and in seminars
  - The PMC decided to concentrate all hardware logistics for development tools for the members of the consortium as well as for Beta customers at AGH-UST in Krakow. The advantage is that at AGH in Krakow is one of the two SAFETYLON testing centers and is a fully equipped training center. Further SAFETYLON development kits will be produced “on demand” by Loytec and who.
  - the LMD management team consisting out of the Consortium Manager (CM), the Technical Project Coordinator (TPC) and the Consortium Administrator (CA) continued to hold the consortium together by structured communication (Projectplace), planning organizing and executing the following meetings: (WP8, WP7, WP1.3)
    - Consortium Meeting (1) one
    - PMC meetings (5)
    - RTD meetings (2)
    - RTD Review Team (4 physical, 3 by Skype / teleconference)
    - IAG Meetings: (6)
    - SME workshops (2 physical, 4 by Skype / teleconference)

- 
- In order to prepare the Period PIII reporting the CM developed a new, very comprehensive version of the Time and Cost reporting Sheet (latest version TCRS V2.3, Excel). Its main feature is the automatic generation of Form Cs for PI, PII, PIII as well as for the total project directly from the basic data per month: hours, hourly rates, travel and consumable costs, subcontracting, overhead and total. Aside from recording hours and other cost, it also allows the correction of hourly rates (relative to planned hourly rates), the overhead factor for FC reporting (by period and by month) as well as the calculation of retroactive adjustments in case of reporting errors in the prior period in the Form C cell “Adjustment of previous period(s)”.
  - All submitted Form Cs were verified with this program and a number of errors could be identified and corrected. In cases where the accounting was carried out in a foreign currency (Poland and Sweden) the members were able to estimate the difference between their own calculated Form C figures and the ones calculated by TCRS– and to quantify the deviation. Hence, the Form Cs for the total project are provided although this has not been asked for.
  - The main cause in members’ delay reporting obligations in PIII were the summer holidays in Europe which stretched virtually over three months. Another cause of delay in Period III reporting was the inability of some members to look for and find an appropriate auditor, despite the fact that EC instructions which were repeatedly sent out as reminders. The third cause was the fact that quite a few members realized mistakes in their Form C reporting of PI and PII and made mistakes regarding the Adjustment. With e-mail correspondence back and forth valuable time was lost.

### **3.4. Contractors and Subcontractors**

All contractors fulfilled their roles cooperatively in accordance with the DoW and as expected, some more in timely response than others. This statement pertains equally to their technical contributions and to their administrative obligations.

A few extraordinary contributions, however, shall be mentioned because they proved to be instrumental for the overall progress and the present state of success of the project:

- RTD performer Innotec held a number of tutorials to educate the contractors about IEC 61508 and safety theory
- RTD performers WHO and ICT thoroughly analysed the possibilities of changing the safety architecture to a 3-processor configuration
- RTD performers ICT, WHO and Loytec volunteered to flexibly adapt their plans and resources to the new architecture
- both SME partners IBT and Nodex changed – with agreement of the PMC – their applications in order to provide suitable prototypes which would better fit a safe model building automation system
- RTD performers Innotec and FH Dortmund volunteered to lead the negotiations with TÜV Rheinland
- LONMARK Deutschland took the lead in negotiating the content of the patent, together with a Safety Patent Group staffed by LONMARK Germany, Innotec, Loytec and ICT.

---

As planned in the DoW the services of several subcontractors have been (continued to be) employed in Period II:

- (1) Samson and Partner, patent lawyers, Munich for drafting and filing the SAFETYLON patent. Since safety is a “hot topic” today, it turned out that several large companies had already made “large and wide” claims. Hence it required several sessions of a special “SAFETYLON Patent Group” to define the objectives of a SAFETYLON patent and the content of the main claims that would give the IAGs the broadest coverage.

The total cost of filing the patent amounted to 37 k€ (incl. VAT), which exceeded the amount planned. Finding and wording the right claims turned out to be significantly more complex than anticipated. The core patent group that did all the work and which is listed as inventors are Jürgen Hertel as coordinator (LMD), Martin Mentzel (FH Dortmund), Dietmar Loy (Loytec), Peter Palensky (ICT/TUW), Pawel Kwasnowski (AGH-UST), and Peter Wratil (Innotec).

- (2) TÜV Rheinland, Cologne for discussion, review and assessment of the SAFETYLON concept specification. In several sessions the overall product and firmware concept as well as extensive safety calculations were discussed with TÜV safety specialists. Most recently, after some early reservations, the TÜV is also willing to accept our new and innovative installation and communications concept with some additional imposed requirements. One of the activities which required several visits at TÜV Rheinland concerned the innovative installation method, which consists of a combination of a conventional, non-safe installation procedure with commercial, non-safe tools and a verification procedure. This method has been claimed in the patent. The approval of the concept paper was granted on September 15, 2006.
- (3) aimcom, a Munich based multi-media company has been contracted to develop the SAFETYLON website. The development is based on Webtailor, a content management system (CMS) which allows the maintenance of content by the members of the consortium. Fig 3.4 -1 shows the sitemap. All three IAGs are participating in content development. It is planned to go online on October 1. The total fixed price for the task is 15 k€, which may be extended by some smaller jobs.
- (4) TÜV Nord / Augsburg has given a training class in IEC 61508 standard, development procedures and functional safetymanagement in English language. All non-German speaking SMEs and one RTD participated. As a result, also TÜV Nord provided us with a competitive quotation on the assessment of the SAFETYLON development, but the pricing was significantly higher (77 k€ vs. 38 k€ of TÜV Rheinland)
- (5) TEMA is the marketing agent of LMD. In period II TEMA created two SAFETYLON rollups for a small both at Hi-Tech house 2006, Moscow, and two panels for an “booth in the booth” at Hanover Fair, 2007. TEMA will also help in organizing the upcoming events. The total amount spent in period II amounts to approx. 5 k€.

As planned in the DoW and in DOW V 2.0 the services of all the subcontractors (except TÜV Nord) have also been employed in Period III. In particular:

- (1) Samson und Partner, to finalize the Joint Ownership Agreement and the SAFETYLON License Agreement for Beta customers

- 
- (2) TÜV Rheinland: to perform the review and assessment of the entire work of the Consortium
  - (3) aimcom: to further develop the structure of the SAFETYLON website and make changes / enhancements to the Content Management System
  - (4) TEMA: to help set up a booth and prepare printed material for the LonWorld 2007 in Amsterdam, the Light & Building 2008 in Frankfurt, as well as plan and organize the logistics and invitations for the series of seminars and training workshops in DACH

### **3.5. Main Achievements**

#### **3.5.1. Milestones**

For the reporting period several deliverables and milestones have been defined (please, note that the Gantt chart on p.34 of the DoW must be shifted forward by 2 calendar months):

Milestone M1: (1.8. 2005) Draft of concept paper. This work has been completed.

Milestone M2: (2.3.2006) Implementation and test of safety chip. This milestone has been missed; the work is delayed by more than six months, since the concept was fundamentally changed from a 2-processor to a 3-processor architecture (see details in WP2)

Milestone M3: (3.6.2006) Demonstration of Safety function by preliminary firmware: this milestone has also been missed and will have the same delay as M2.

Milestones need to be updated in accordance with list of achievements above

#### **3.5.2. Deliverables (see also section 8, Appendix 2 – Plan for Using and Dissemination of Knowledge)**

In addition the following Deliverables fall into the Reporting Period I: (DoW, pp. 36 and 37)

(1) Deliverable D1: WP 8, due 09/2005) Presentation of the project.

An early project presentation has been ready by the due date, but has subsequently grown and become more differentiated. The first exhibition where the SAFETYLON EU project was introduced to an expert audience was LONWORLD 2005 in Paris (10/05). However, no technical content was shown or conveyed. Also, since the architecture has been modified since then, the presentation(s) had to be updated and amended continuously. The major three events where SAFETYLON was introduced as a new concept were High Tech House 2005, Moscow (11/05), Light and Building, Frankfurt (4/06) and Hanover Fair (4/06). For the latter two tradeshow a new suite of presentations has been generated, both in German and English. These are:

- The general principles of Safety
- The EU project
- The SAFETYLON architecture
- The application areas and markets of SAFETYLON

All presentations can be viewed and downloaded from [www.projectplace.com](http://www.projectplace.com) (folder EC Reporting Material)

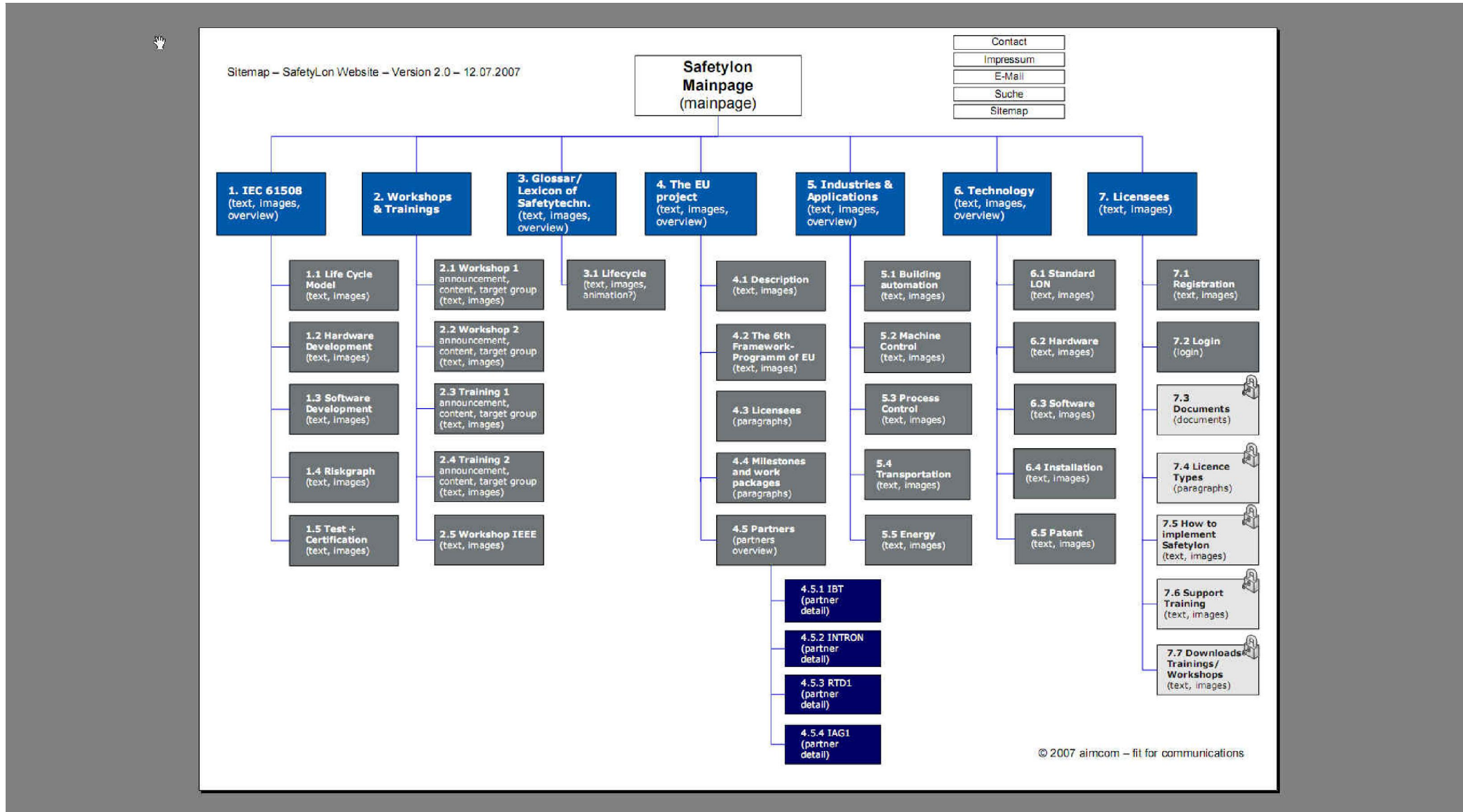


Figure 3.4 – 1 SAFETYLON Website – Structure Version 2.0

- 
- (2) Deliverable D2: (WP1/WP5; due 12/2005) Report on required specifications for different safety applications.

This report is now complete including the specification of emergency lighting created by IBT. It has taken significantly longer than expected, because the SMEs had to go through a learning curve to understand and express their requirements with regard to safety. In order to harmonize all specifications a special SME workshop was held in Augsburg in April 2006. A particularly good example to understand the functioning of safe profiles is an animated presentation of a fire scenario created by ZDANIA, Krakow.

- (3) Deliverable D3: (WP6.1, due 03/2006) Plan for exploiting IPR (SAFETYLON patent)

A preliminary patent has been filed on April 21, 2006 at the European Patent Office under the title "Safe Communication in a Network" to meet a deadline before the beginning of two tradeshows in Germany. This early filing procedure will not impose any restrictions but will give the Consortium up to 12 months more time to file the final patent, which will probably then feature additional claims and additional material. However, in order to begin with the dissemination process, the latest targeted filing date shall not be later than September 30, 2006.

- (4) Deliverable D4: (WP6, due 04/2006) Plan for Exploitation and Dissemination Activities during the project.

A plan for Exploitation and Dissemination of the IPR has been developed for the three European regions of IAG responsibility, i.e. Central, East and Nordic. It contains the details of the agreement between the three IAGs including the principles and terms of cooperation across the territories which is currently being drafted in a Joint Ownership Agreement, to be completed by September 2006. Further, the plan contains a License Agreement with details about the type of licenses available, the licensing terms, the deliverables for each license type, the support of the licensees, and, of course, the license fees. It had been decided early in the project by the Project Management Committee that all contractors in the SAFETYLON project shall enjoy a lifelong free of charge license of Type A which is a full license of a market value of 75,000 €. Nevertheless, all contractors will have to sign the very same License Agreement as any external third party.

- (5) Deliverable D5: Activity report for Period I (completed, conditionally approved by EC in an Approval document dated April 6, 2007)

- (6) Deliverable D6: Protocol code LON chip firmware in C for Neuron chip: merged with D8.

- (7) Deliverable D7: Protocol code LON chip firmware in C for LC3020 chip: merged with D8

- (8) Deliverable D8: Safety Operating System (SOS); includes Safety Layer for ARM 7 (WP2, due 2/2007): Protocol code safety chip firmware . Based on the ShortStack Microserver architecture, the embedded protocol layers for Neuron-based SAFETYLON communication were implemented, and – based on the ORION stack - embedded protocol layers for LC3020 based SAFETYLON communication (as described in 3.8 of Period I Activity Report) were partially implemented and will be delivered in Period III. This is due to the fact that the alternative D6 technology was earlier available and implementing the ORION layers later is of no technological risk. For obtaining running modules as soon as possible, the team has focused on D6 and will add D7 in summer 2007.

Due to the necessary shift to a 3-chip architecture and due to numerous unplanned safety requirements, the firmware for the higher protocol layers and the safe operating system

---

(including self tests, I/O tests, protocol tests, SW monitoring, etc.) was way more effort that had been expected. This deliverable will be finished in Period III.

- (9) Deliverable 9: Modified development tools for LONMARK objects and Safety Application Builder. This Deliverable is described in detail below and is completed as re-planned (month 24). It still needs testing in a real SAFETYLON network.
- (10) Deliverable D10: Configuration and Installation tool for Neuron chip and LC3020 chip. This Deliverable is largely completed, but still needs some polishing and testing. It will be completed as re-planned (in month 27)
- (11) Deliverable D11: Mid-term review / 18 months report. This Deliverable has been carried out in a PMC meeting on November 30, 2006, but due to the overall delays it has been merged with Deliverable D15 (24 months report)
- (12) Deliverable D12: Safety layer testing tool; this Deliverable, prepared by AGH-UST, is well advanced and is currently being applied to the latest release of the safety software from ICT. While the first version will be ready on month 27 as re-planned, improvements will be made during the remainder of the project when further releases and safety applications will be tested.
- (13) Deliverable D13: Demonstrator module (Neuron chip). Developed and produced in quantity of 70 units by WHO Ingenieurgesellschaft, this core module is now ready to be used for SME development kits and training kits (see Figure 4.4 – 8)
- (14) Deliverable D14: Demonstrator module (LC3020 chip). Developed and produced in quantity of 40 units by Loytec this second, pin compatible core module is a more powerful version which will be preferably used in applications that require more computing power and, in addition to a LON FT channel, an Ethernet / IP channel for backbone connectivity.
- (15) Deliverable D 15: Period PII Activity report, together with a Management and an updated version of the DoW (Version 2.0); this report is delayed by more than 30 days due to vacation time

### **Deliverables completed in Period PIII**

- (16) Deliverable D16: Plan for Exploitation and Dissemination Activities after the project (PLUG)

The plan describes the ideas, plans and time horizon of the work to be continued after the end of the project. While times are getting increasingly difficult for any type of investment the Consortium members will certainly find it hard to find OEMs to invest in a new technology which does not promise a quick ROI. Therefore the main challenge in the years ahead will be to maintain the cooperation of the IAGs and maintain the network and working relationship of SMEs and RTDs who, collectively, have acquired the knowledge and experience to successfully continue this work.
- (17) Deliverable D17: Demonstrator emergency lighting application (IBT)
- (18) Deliverable D18: Demonstrator elevator application (INTRON)
- (19) Deliverable D19: Fire Damper Actuator, Safety Door and Escape Path Manager (IBT)
- (20) Deliverable D20: Demonstrator Fire Detection and Intrusion Protection (ZDANIA)

- 
- (21) Deliverable D21: Demonstrator Emergency Exit Button (NODEX)
  - (22) Deliverable D22: Demonstrator access control unit (APICE)
  - (23) Deliverable D23: Demonstrator Fault Indication and Switch Control panel (UNITRO)
  - (24) Deliverable D24: Demonstrator safety-network management tool (NEWRON)
  
  - (25) Deliverable D25: Test-bed for demonstrator modules FH Dortmund)

These eight SME Deliverables have all been completed as described in the DoW V 2.0 and in sections 4.5.1 to 4.5.9 below. Due to the leadership of Chris Brönnimann (IBT) the SMEs have complied to the well defined requirements with regards to specification, coding, testing, documentation and reporting guidelines. The quality of the different Deliverables varies somewhat as one might expect in a Consortium such diverse as this one. Some SMEs, notably IBT, Zdania, and Newron went beyond the DoW requirements especially regarding the depth of understanding and applying Safety Functional Management (SFM), testing and documentation.

Since this FP6 project has been initiated with the idea of enabling SMEs to adopt and accept a new technology (Safety according EN 61508) the transfer of knowledge and R&D results was of particular importance and concern throughout the project. It can therefore be summarized that this objective has been fully achieved.

- (26) Deliverable D26: TÜV certified core modules

Upon request of the PMC, the TPC and CM commissioned TÜV Rheinland with the task to assess the development work and the results of the RTD work in general and the development of the hardware and software in particular. The report No. 968/EL 426.01/08 of April 24, 2008 comes to the following conclusion: “The inspection of the test institute shows that the general approach that has been done to fulfill the requirements of the EN 61508 is promising. The documentation of the project shows at the moment some discrepancies but the open points can be easily removed within a future type approval.”

This statement is very much in line with the conclusions of the RTD review group stating that the SAFETYLON hardware and software development has achieved the best possible result given the constraints of an R&D project and the diverse functional requirements of eight different prototype applications. According to TÜV, the created non-commercial generic prototype products like core modules, development kit hardware, SOS software, I/O hardware, tool software, testing environment and associated methods and procedures can only be finally evaluated and certified in the event of a TÜV type approval of a “real life” SAFETYLON product. The assessment and certification methods of TÜV are clearly directed and typically applied to commercial safety products, but not to generic prototype products like in the case of SAFETYLON. For prototype products an application of a full EN61508 type approval and certification process was neither considered meaningful nor relevant. But “promising” as the conservative TÜV nicely states. By this logic the PMC, TPC and CM are convinced that Deliverable D26 is fulfilled in a better and more pragmatic way than originally anticipated, especially with regard to the future of SAFETYLON.

- (27) Deliverable D27: Training Kit (AGH-UST)

This Deliverable consists of a safe sensor (emergency push button) – actuator (lamps) assembly in a ruggedized yellow suitcase. It is built in such a way that the students can experiment with the applications software as well as manipulate the circuitry in order to

verify the safe state. All IAGs have been supplied with several Training Kits in order to be able to run classes even after the end of the project. These kits can also be built to order. On request by RTDs, SMEs or potential licensees. The kits were a prerequisite for the training classes of the following Deliverables D28 and D29.

(28) Deliverable D28: Training courses for Consortium LON User Group members

The training classes for LON User Group members have been combined with the classes for external attendees (D29) since most internals had already been informed before and trained individually on Light & Building 2008 in Frankfurt. Therefore the Deliverable is now referred to as D28&29

(29) Deliverable D29: Training courses for Non-consortium attendees

The training classes for Non-consortium attendees have been combined with the classes for LON User Group members (D28) since most internals had already been informed before and trained individually on Light & Building 2008 in Frankfurt. . Therefore the Deliverable is now referred to as D28&29

(30) Deliverable D30: Final report

The Final Report consists of:

| <b>The Management Report</b>  | <b>The Activity Report</b>                                 | <b>Signed Form Cs</b>              | <b>Audit documents</b> |
|---|--|------------------------------------|------------------------|
| 1 Management Report (incl. Actuals and Form C tables)   | 1 Management Summary Report                                | 15 Form C pdf files, signed        | 16 pdfs                |
| 1 Summary Financial Report: Excel table with DoW V 2.0 Plan and EC Actuals for PI - PIII                              | 1 Activity Report for PIII                                 | 1 Audit document, signed (Innotec) | 1 ZIP file             |
| 1 Distribution of EC contribution: Excel book with plans of DoW V1.0 and V2.0 as well as Actuals for PI, PII and PIII | 1 Activity report for the complete Project (PI, PII, PIII) | 1 ZIP file                         |                        |
| .doc, .xls, and pdf files   | .doc and pdf files   | Originals sent to EC               | Originals sent to EC   |

**Table 3.4 – 2 Contents of the Final Report (Deliverable D30)**

### **3.5.3. Hardware and Software Design**

An achievement that needs special mentioning is the significantly improved hardware and software design (3-processor architecture) relative to the DoW proposal (2-processor architecture) which has been jointly created in Work Packages 1 to 4. The reasons for this change was the realisation and the calculatory proof that the Safety Integrity Level 3 – and subsequently SIL4 - could otherwise not be achieved. The benefits from this improvement are manifold:

- (1) the safety hardware- and firmware architecture is (almost) symmetrical between the primary and the secondary safety processor which saves development effort and makes the ongoing software maintenance and support much easier and less expensive
- (2) the architecture is more powerful, transparent and better to assess by TÜV Rheinland

- (3) a single Safety Operating System (SOS) and a single Safety Layer (SL) can be used for both front-end communication chips (Neuron FT3120 from Echelon, LC3020 from Loytec)
- (4) the application programming interface (API) is a functionally rich interface and is absolutely identical for the primary and secondary safety chip
- (5) over time a well tested and proven safety function library will be built as embedded firmware which will facilitate the development of robust and error free application software – which will make the acceptance of individual device types by TÜV less costly
- (6) the safety core is replaceable without any changes to the application software and the I/O hardware

### **3.5.4 Communication**

All the technical achievements could not have been reached without means of efficient and productive communication like the web based project coordination and archiving tool *Projectplace* which allows the Consortium Manager to run the project like a virtual company. All partners collaborate on an equal and “democratic” basis. This is a huge step forward and a great socio-economic experiment for most of the contractors involved. With this positive experience in mind some of them will definitely continue to work together as business partners across Europe after the end of the project.

Communication and cooperation has been further stimulated by a series of well organized meetings and workshops among the contractors. So far there have been 8 RTD panel meetings/workshops, 3 IAG panel meetings and 4 SME meetings/workshops. Every single meeting has increased the effectiveness of the teams. All meetings are well prepared by an agenda and followed up by minutes for later reference, in particular concerning decisions taken and actions to be performed.

## **3.6. Most Important Problems Encountered and Corrective Actions taken during PIII (JH and MM/TPC)**

### **3.6.1. Knowledge**

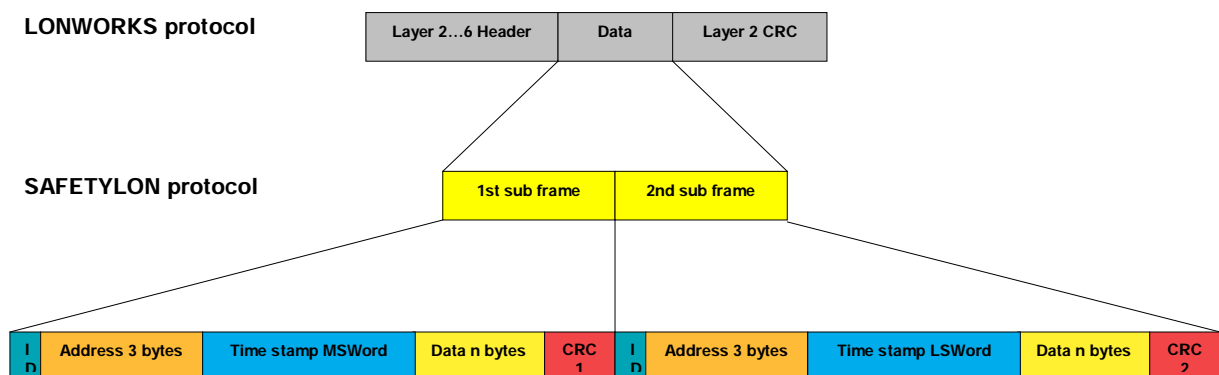
In the early phase of the project it turned out that the lack of knowledge of the norm IEC 61508, safety terminology and safety theory in general and as it pertains to LON has been a serious problem. This deficit resulted in lengthy discussions and debates in the early meetings about seemingly trivial details and has impaired the progress enormously. This problem had been grossly underestimated in the DoW and the resulting “slow start” of the project probably accounts for more than 2 months delay in all R&D work packages. In order to relieve the problem, Dr. Peter Wratil of Innotec presented mini-tutorials on all the meetings in the early days and made a number of publications available for individual reading. As more and more specification documents were published in Projectplace by the more experienced owners of safety know-how, the use of correct terminology and the overall understanding of the prospected solution improved. Later, most German speaking members participated in a workshop held by TÜV in Augsburg, to get a fully systematic introduction into the subject

matter. For the other partners it is planned to organise the same workshop in English language, also as a preparatory measure for the exploitation and dissemination phase.

### 3.6.2. SAFETYLON protocol

A minor yet very important problem to solve was taking the decision on the final details of the SAFETYLON protocol. The decision was about a trade-off between an efficient, i.e. short protocol and a SAFETYLON message protocol which would still have room for expansion. In the course of many iterations the RTD panel devoted to the subject the main choices were between

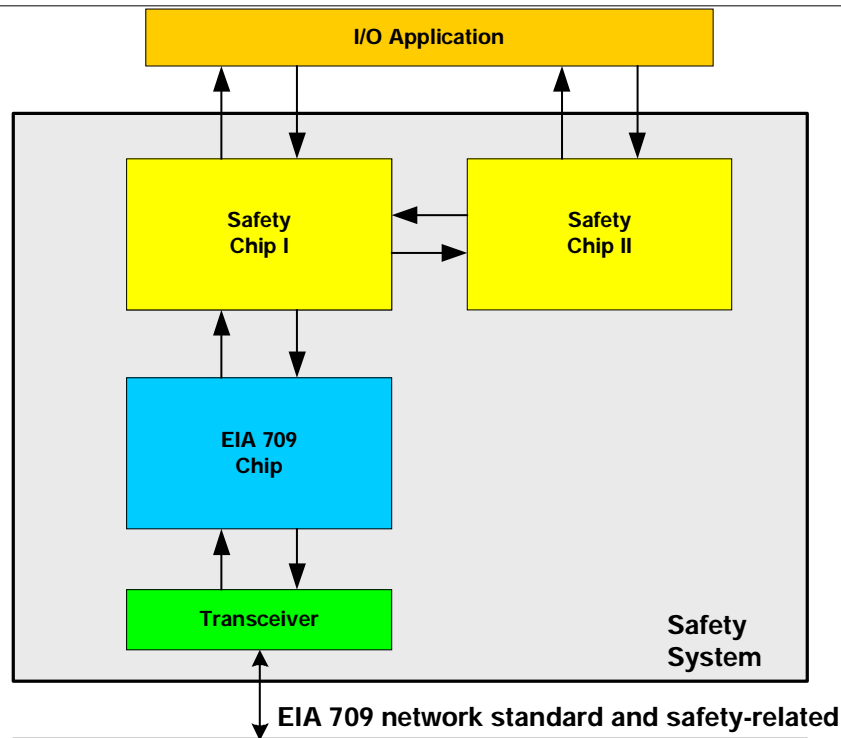
- two ways of ensuring LONMARK interoperability in full compliance with the LONMARK Interoperability Guidelines V 3.4
- two alternative models for time synchronisation
- compact or elaborate addressing schemes
- efficient and flexible CRC calculations
- optimized system performance even for slow media, e.g. Powerline or RF



**Figure 3.6 -1: The SAFETYLON protocol**

### 3.6.3. Hardware- and Firmware Architecture (DL/Loytec)

A major problem, however, concerns, as mentioned before, the decision to replace the seemingly simple 2-processor architecture (as proposed in the DoW, p.26) by a more powerful, yet more complex 3-processor architecture with two identical safety processors for parallel processing of messages, I/O and applications. The decision bears a lot of implications regarding the details of the work packages and the interworking between the R&D performers. It also has direct consequences regarding the application development tools, the commissioning tools, testing tools and the test bed for final testing of prototype devices. In other words, this decision created a whole new scenario of options and alternative designs. To cope with this unexpected challenge the RTD panel – which by now had been enlarged by involving virtually all project engineers - spent considerable time in weighing and communicating the advantages and disadvantages of alternative specifications and designs. Given the time and financial constraints of the DoW plan, some “nice to have” features had to be taken off the wish list of SMEs in order to free time for unplanned effort.



**Figure 3.6 - 2: The SAFETYLON Hardware Architecture**

The architecture decision process has caused another two months delay relative to plan. However, the entire consortium is convinced that this time and effort was well spent in order to later reap the benefits of a more robust, long lasting and future oriented safety design. The new solution has the additional advantage that for both types of EN 14908 chips (Neuron FT3020 and Loytec LC3020) an identical safety hardware architecture will be created. This will decidedly facilitate the market acceptance of SAFETYLON because the IAGs and all contractors can now offer a genuine dual source solution.

As mentioned, the architecture decision creates in its wake an additional problem for most SMEs who are exclusive users of the Neuron chip based technology from Echelon today. These SMEs have been using application development tools from Echelon (NodeBuilder) and have invested in the proficiency of their software engineers to develop their applications using a special variant of C (Neuron C). Now, the development environments for SAFETYLON applications will be different from the environments that SME engineers are used to. To overcome this problem the advantages of the new situation have been carefully assessed, documented and communicated with all SMEs, and consensus and agreement was reached among all consortium partners to leave the Echelon development tools behind in favor of a choice of either a popular commercial (IAR Systems AB, [www.iar.com](http://www.iar.com)) or public domain development environment (GNU tools chain, [www.gnuarm.com](http://www.gnuarm.com)) or even other proven in use development environments. It has become clear to everybody that the new architecture will create several new business opportunities in the future.

### **3.6.4. Safety Software and the Safety Operating System (SOS) (TN/TUW ICT)**

A further problem was taking the decision of writing “our own” Safety Operating System (SOS) because it appeared that the time and cost of writing such software had not been foreseen and planned in the DoW. Rather, it had been assumed that it would be quicker and

---

easier to select one of the many commercially available embedded OSs. There were, however, five major points that favored the decision for a new development:

- TÜV certification requires that each and every line of code in both safety chips must be tested, documented, submitted and explained to the TÜV software engineers
- the requirements of the SOS demand stringent control on the timing and do not allow any CPU interrupts from other sources
- commercial operating systems are designed in a universal way and have therefore typically too large memory footprint
- testing and finetuning of the SOS to the specifics of the various safety testing operations demands specific parameterisation control
- there is no need to charge future licensees for an embedded SOS license

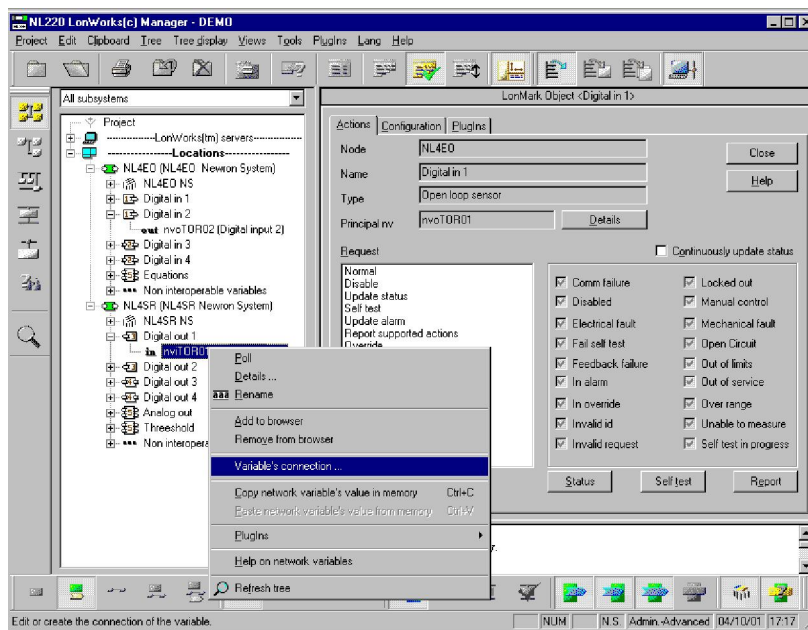
All five points are unlikely or impossible to find in a commercial embedded OS, let alone the undesired “overhead” of unused and potentially “non-safe” functionality.

The RTD panel and the PMC discussed the problem extensively and decided to accept the risk of even further delay, asking the RTD performer ICT to put more resources behind the safety chip firmware development. Especially the testing and documentation will take considerable time and effort. The new plan (Gantt chart on p.59) reflects the new data for WP2.

At the end of PI the PMC decided to fund the work of TUW ICT with an additional amount of additional 50 k€ (contributed by the IAGs) in order to obtain a robust, well tested and high-quality product.

### **3.6.5. Installation and Commissioning concept (PF/MH of FH DO)**

Finally, the installation and commissioning concept of SAFETYLON seemed to be an insurmountable problem in the beginning since all standard LON commissioning tools are PC based. But PCs, PC operating systems and PC based applications like tools are inherently non-safe (except one known TÜV approved but very expensive commercial safe configuration tool which was excluded from the very beginning). Instead, the group of FH Dortmund, together with French SME Newron System developed an innovative scheme which will allow the use of non-safe commercial tools (based on Echelons LNS network management tool base). The principle is as simple as effective: in a first step the installation and commissioning is performed with a commercial non-safe tool like LonMaker from Echelon or NL220 from Newron System. In a second step safe addressing, binding, parameterisation and application download will be added to each of the safe nodes to complete the installation. In a third step all safe network management information is read back from the safe nodes and is verified against the original information, both automatically and by a qualified person on a screen and in a printed list.



**Picture 3.6 - 3: The NL220 installation tool will be equipped with additional Plug-Ins for safe installation, binding and parameterisation**

This innovative method has been investigated and approved by TÜV Rheinland in the concept paper. Therefore the previously anticipated risk that the proposed installation method would not be accepted by TÜV and that a new concept would result in additional work and cost for the consortium did not materialize !

### **3.7. Superiority of the 3-processor solution for the SMEs (CB/IBT)**

The new solution is technically superior as explained in chapter 3.6.3 in the Activity Report and summarized above. But it is also superior as far as the interests of the SMEs are concerned.

During the project (WP5):

- all core SME's will be provided with an identical SAFETYLON Application Development Environment (SADE), both for hardware and software, i.e. two SAFETYLON core modules (Neuron FT3120, Loytec LC3020), a general purpose prototyping motherboard, a SAFETYLON prototyping I/O board, model applications (source code), documentation
- all core SME's will be provided with IEC 61508 compliant testing programs and testing documentation
- core SME's will be thoroughly trained in a 2 day workshop (March 20 and 21, 2007) which is preceded by an information and preparation workshop held on January 25, 2007.
- core SME's can first prototype on SADE with both SAFETYLON core modules in order to test the performance and functional behaviour of their application prior to developing the final hardware and software
- core SME's may choose from several commercially available (e.g. IAR) or open source (e.g. GNU tool chain) C-development environments as their preference.
- the fact that all core SMEs will use the same SADE will facilitate the planning and establishment of a testbed for all SME prototypes (WP5.9)

After the project:

- All advantages available to the core SMEs will be available to other SMEs under license by the three IAGs
- All SMEs will be able to achieve TÜV certification for their SAFETYLON products at affordable conditions provided the consortium will achieve the TÜV certification of the SOS (prerequisite !)
- the fact that SAFETYLON will use standard C or C++ development will attract new SMEs which are currently not part of the LON community

### 3.8. Partial merging of Deliverables D6, D7 and D8 (DL, TN)

The partial merging of the Deliverables D6, D7 and D8 (see section 8.1, Table 8.0 -1) is a direct consequence of moving from a 2-processor architecture to a 3-processor architecture. That is why the SAFETYLON protocol codes for the Neuron FT3120 and the Loytec LC3020 are no longer necessary. Instead it will be replaced by a new software architecture in Safety chip 1 consisting of:

- A Communication Layer (Short Stack for FT3120 and Orion Stack for LC3020 combined)
- a Network Access Layer (NAL)
- a Safety Chip Interface (Safety Chip 1 to Safety Chip 2) (SCINT)
- a Safety Layer (SL)
- an Application Layer Interface (API)
- the Safety Operating System (SOS), managing all previous layers

|                                      |                               |                               |
|--------------------------------------|-------------------------------|-------------------------------|
| Application Layer Interface (API)    |                               | Safety Operating System (SOS) |
| Safety Layer (SL)                    |                               |                               |
| Network Access Layer Interface (NAL) | Safety Chip Interface (SCINT) |                               |
| Short Stack                          | Orion Stack                   |                               |
| FT3120                               | LC3020                        |                               |

**Figure 3.8 - 1**

For the Safety Chip 2 the architecture looks similar, consisting of:

- a Safety Chip Interface (Safety Chip 1 to Safety Chip 2) (SCINT)
- a Safety Layer (SL)
- an Application Layer Interface (API)
- the Safety Operating System (SOS), managing all previous layers

|                                   |                               |
|-----------------------------------|-------------------------------|
| Application Layer Interface (API) | Safety Operating System (SOS) |
| Safety Layer (SL)                 |                               |
| Safety Chip Interface (SCINT)     |                               |
| Safety Chip 1                     |                               |

**Figure 3.8 – 2**

The total amount of 38 person months which had been allocated to ICT in WP2 for the three deliverables D6, D7 and D8 is now being used for

- the porting and adaptation of the Short Stack from Echelon
- the development of an equivalent Orion Stack for LC3020
- the development of a Network Access Layer (NAL)
- the development of the Safety Layer (SL) which comprises the handling of the Safety protocol, and which is now part of both safety chips
- the development of a comprehensive Application Layer Interface (API), also part of both safety chips
- the development of the Safety Operating System (SOS) which is an entirely new piece of software, also part of both safety chips
- documentation of all software
- preparation of the SOS and SL documentation for later certification by TÜV

In summary it can be stated that the new improved hardware and software architecture provides the following advantages:

- it is more symmetric since it uses identical safety chips and partially identical code in both safety chips (SOS, SL, API)
- because of this symmetric design it is much easier for SMEs to develop their own products, because they can use a single integrated development and testing environment.
- lower costs will be incurred for product certification by TÜV, because even the testing for TÜV is less complex
- it lends itself to much better maintainability for the system level software like SCINT, SL, API and SOS as well as the installation tools and the application software of the SMEs
- it can be TÜV certified on a pure software source level (SOS, SL, API)

The latter point is potentially covered by the deliverable D26 (TÜV certified core module). However, our current estimate shows that instead of 1 person month we will need some additional 15 person months plus additional subcontracting to TÜV in order to achieve certification of the SOS, SL and API source code. This effort is currently being replanned as part of WP6.1 (Exploitation).

---

## 4. Work Packages Progress

In this chapter the Work package leaders give their own brief work package reports for the first and second 12 months reporting period. The language is more technical than in the other chapters. Some of the details can only be properly understood and appreciated when reading the respective technical papers behind it. The deviations from the DoW V1.0 work plan and the various corrective actions have all been covered summarily in chapter 2 and are not repeated here. Instead the individual reports are written in a sober, technical language and cover the objectives, the work performed and the results achieved.

### **4.1. Work Package 1: Requirements, Specifications, Quality Assurance and Certification (P. Wratil / M. Mentzel, Innotec)**

#### **4.1.1. Objectives**

Work package 1 of the SAFETYLON project ‘Requirements, specifications, quality assurance and certification’ aims at providing requirements and specifications for the SAFETYLON system in the early phase of the project, to assure the technical quality during the project and to prepare a certification of the SAFETYLON module(s) and software by the German TÜV. Following is a compact survey of the objectives and results within the first period of 12 months of the SAFETYLON project.

##### **4.1.1.1.WP 1.1 Definition of System Requirements Specifications (SRS)**

The specifications of the system requirements – meeting the international standards IEC 61508 and EN14908 and also the specific application requirements of the SMEs – are the basis for all the further work done within the project. The specifications cover all the details required for the WP1 to WP4 .

##### **4.1.1.2.WP 1.2 Accompanying Technical Coordination and Certification Activities**

Based on the System Requirements Specifications (SRS) a concept approval is requested by TÜV. This concept approval is required to assure a system concept according to the international standard IEC 61508 which then delivers the base for all further implementation specifications.

The functionality of the core modules (hardware, embedded and tool software) covers all application specific basic requirements of the project’s SMEs. Obviously, a safe product (application specific device or system) requires its own type approval by TÜV in order to put the product in circulation. The integration of the core modules into the SME specific prototypes and future products should be as easy as possible – not only from the technical point of view, but also regarding the SME’s type approval process. Therefore it becomes important to obtain a SAFETYLON technology evaluation and assessment certificate from TÜV for each core module based on either a Neuron FT3120 core module or a Loytec LC3120 core module. Such a certificate shortens the individual type approval process of the SMEs and significantly lowers the cost of the type approval certificate significantly. Innotec has assumed the responsibility to act as a single interface or proxy of the consortium to TÜV

---

Rheinland – within the scope of the project and beyond, to support OEMs implementing and certifying their SAFETYLON products.

While the SAFETYLON technology assessment certificate of TÜV has to be obtained within the scope of the project the process of a full product type approval foremost for the core modules and, in particular, for the SME prototypes, will definitely exceed the scope and the time limit of the project. This process depends on the ongoing developments of the project's SMEs and future product developments of licensees (typically OEM manufacturers– within and beyond the scope of the project.

## **4.1.2. Results**

### **4.1.2.1.WP 1.1 Definition of System Requirements Specifications (SRS)**

Learning more about the international standards most of the project partners participated in a very effective training held by the TÜV Nord. In March 2007 the course was repeated in English and most non-German speaking consortium members participated.

All of the specifications have been completed. The already TUV approved concept specification (as part of the SRS) has been updated following the experiences gained in the final development process. Due to the supervision of INNOTEK it has been guaranteed that these minor deviations / improvements do not interfere with the already granted approvals by TUV.

### **4.1.2.2.WP 1.2 Accompanying Technical Coordination and Certification Activities**

The technical coordination has directly started in the beginning of the project with the creation of the specifications and is well established within the project and has turned out to be a really necessary management task on a technical level during the project.. On a regular basis meetings of RTD and SME performers take place and reviews are done based on the documents, all coordinated or reviewed by Innotec the main RTD performer for this task.

To reach a certification for the technical results within the project the German TÜV has been involved in the specification and development processes. This coordination is also performed by Innotec.

The German TÜV has issued a concept approval for the SAFETYLON system concept. This is a major milestone within the SAFETYLON project.

Moreover TÜV is involved in the final certification process. For this final assessment a lot of documents and some samples have to be delivered. Typical documents are: concept specifications, hardware specifications and design, safety related PFD and PFH calculations for hardware design, embedded software specification and design both for SAFETYLON operating software and application frameworks, coding rules, tool software specification and design, test specifications, design and results, calculations and description (user handbook). The documents have been supported by all partners and structured and presented to TÜV by innotec. Consequentially the German TÜV has issued a certification for the SAFETYLON developments. This is a further major milestone based on the concept approval which provides valuable development results both for the SMEs and future licensees.

### 4.1.2.3. Review of Documentation

In Period III one of the most important activities was the review of the entire documentation that had been created by all consortium members during the course of the project. A review team under the direction of the TPC was set up and reviewers were recruited primarily from the RTDs and IBT. The result is a list of documents which, as a collection, constitutes part of the Deliverables of the SAFETYLON License Agreement ( SLA /ANNEX II):

**ANNEX II indicates all Deliverables that will be supplied by licensor to licensee once this agreement has become valid. In the case Licensee wishes, in addition to the Deliverables, further information, upon respective request, Licensor will provide requested information if available or will support Licensee to obtain requested information.**

#### I Concept Specifications and Approval [#10000]

- #10001, Specification Safety related System Structure for SAFETYLON V0.1, 2005-09-22
- #10002, Specification SRS FMEA Safety related Devices for SAFETYLON V0.2, 2005-09-10
- #10003, Specification Safety related Life Cycle Model for SAFETYLON V0.3, 2006-01-03
- #10004, Coding Style Guide for Safety related Programming of Embedded Systems V1.1, 2005-12-30
- #10005, Frame Format for SAFETYLON V1.2, 2007-09-10 [UPGRADED VS. APPROVAL]
- #10006, D\_Specification Safety related Addressing, Binding and Configuration for SAFETYLON\_V1.0\_MME.pdf V1.0, 2006-08-28
- #10007, Concept Approval, TÜV Rheinland, 2006-09-15

#### II Hardware Specifications and Design [#20000]

- #20001, SAFETYLON Hardware Requirements Specifications V0.7, 2006-04-28
- #20002, Pin assignments for the safety chips V1.2, 2006-10-24
- #20003, System Requirements Specification and System Design Description for WP4 Reference Design V1.2, 2007-04-18
- #20100, Hardware Schematics, Parts Lists, PCB Layouts and Production Data
  - #20101, I/O-Board
  - #20102, Neuron Core Module
  - #20103, LC3020 Core Module
  - #20104, Main Board
- #20200, PFD and PFH Calculations for Hardware

#### IV Software Specifications and Design (development tools) [#40000]

- #40001, SAFETYLON Software Requirements Specification For Safe Shortstack Installation Tool, V0.1, 2006-11-27
- #40002, SAFETYLON Software Requirements Specification For Safety Chip Orion Stack Installation Tool, V0.3, 2006-11-24
- #40003, Software Design Description for SAFETYLON Application Builder V0.2, 2008-04-14
- #40004, SAFETYLON LONMARK Device Resource Files
- #40005, Source Code for SAFETYLON Application Builder V0.3, 2008-05-25
- #40006, Compiled Installation Script for SAFETYLON Application Builder V0.3, 2008-05-25
- #40007, Source Code and Project Files of Installation Script for SAFETYLON Application

<sup>1</sup> The embedded ORION Stack Server Library is available only as a compiled binary file. Source code is not available. In case of required

|  |
|--|
| software support (e.g. bug fixing, modification or extension) Loytec needs to be contacted for supplying support. This may cause additional            |
| <b>V <u>Software Specifications and Design (network management tools) [#50000]</u></b>   |
| #50001, Software Requirement Specification for SAFETYLON Library of PC Tool Software V0.7, 2007-05-22  |
| #50002, Software Requirement Specification for SAFETYLON Application of PC Tool Software V0.4, 2006-04-07  |
| #50003, Software Design Description for Safe Layer Library of PC-Tool Software V0.6, 2007-11-08  |
| #50004, Software Design Description for SAFETYLON Application of PC-Tool Software, V0.1, 2007-08-16  |
| #50005, Documentation of SAFETYLON Library API, V0.9, 2008-05-22   |
| #50006, Source Code and Documentation of SAFETYLON Library and Application of PC Tool Software, V0.9, 2008-05-22                                       |
| #50007, Compiled Installation Script for SAFETYLON Library and Application of PC Tool Software, V0.9, 2008-05-24                                       |
| #50008, Source Code and Project Files of Installation Script for SAFETYLON Library and Application of PC Tool Software, V0.9, 2008-05-24               |
| <b>VI <u>Test System Specifications and Design [#60000]</u></b>  |
| #60001, SAFETYLON Black Box Safety Functions Test Plan, V0.23, 2007-04-15  |
| #60002, SAFETYLON Black Box Safety Functions, Test Design Test Case Specification, V1.0, 2008-05-14  |
| #60003, System Requirement Specification for testing environment, V0.3, 2007-08-21   |
| #60004, System Architecture of SAFETYLON Test Suite, V0.2, 2007-05-16  |
| #60005, Software Design Description for testing environment, V0.2, 2007-08-22  |
| #60006, SAFETYLON Test Suite Installation Guide, V1.1, 2008-01-29  |
| #60007, SAFETYLON Test Suite Technical Reference, V1.0, 2008-05-10   |
| #60008, Hardware Connections for Power Supply Tests, 2008-02-26  |
| #60009, SAFETYLON Test Suite Release Manager, V3.0, 2008-02-15   |
| #60010, RTH Testing Framework ( <a href="http://sourceforge.net/projects/rth">http://sourceforge.net/projects/rth</a> ) customized, V1.6.1, 2008-02-26 |
| #60011, SAFETYLON Test Suite Environment, 2008-04-30   |
| #60012, Source Code and Documentation of SAFETYLON Node Tools Library, 2008-02-25  |

**Table 4.1 – 1 List of reviewed and officially released SAFETYLON documentation**

## 4.2 Work Package 2: Development of Safety Chip (Thomas Novak, ICT)

### 4.2.1. Objective

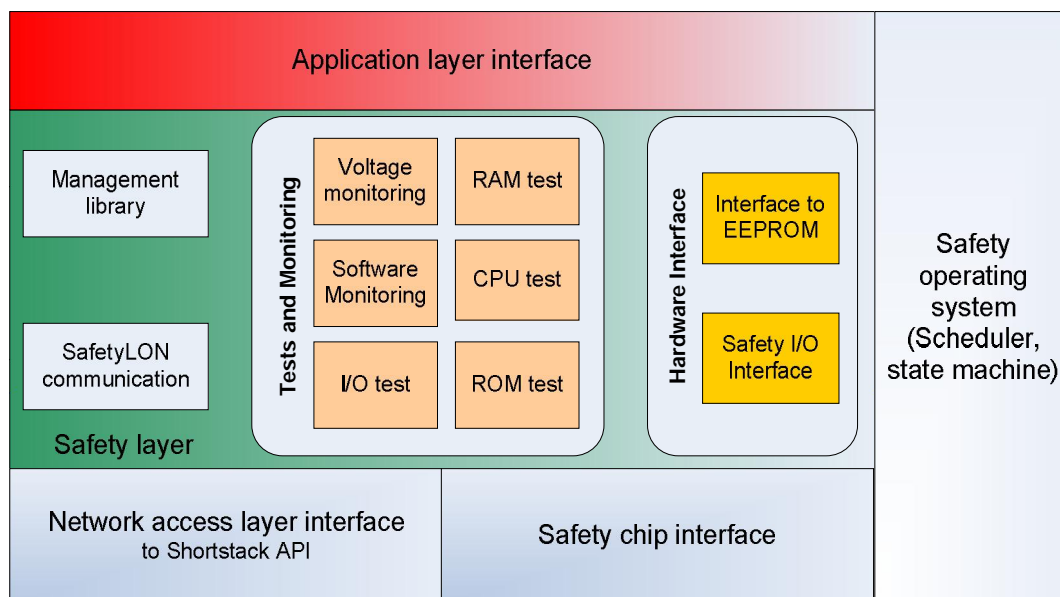
Work Package 2 of the SAFETYLON project ‘Development of safety chip’ aims to provide a number of embedded software components for the SAFETYLON system (Figure 5). Within Period 2, prototypes (consisting of selected software components) are developed and tested.

### 4.2.2. Results

During Period 2 two software prototypes were created. The first one runs on hardware consisting of the ATMEL AT91SAM7S-EK development kit and ECHELON Mini EVK Evaluation kit. The second one is based on a safe main module in combination with a Neuron FT3120 core module.

The first software prototype provides the following functionality:

- Sending and receiving of safe network variables (NV) between two safe nodes
- Communication interface is the Shortstack from Echelon and Shortstack API running on Safety Chip 1 that enables exchange of safe network variables between nodes (Driver running on Safety Chip 1 for communication was created.)
- Commands of Shortstack API are encapsulated in functions of the network access layer
- Communication via SPI (Serial Peripheral Interface) between safety chips to make safe network communication possible (Both safety chips are involved in the communication process.)
- Data in network variables is sent due to an external event such as pressing a button on both safety chips at the same time (Application layer interface functions were created.)
- Data received by means of network variable results in triggering a LED on both safety chips simultaneously



**Figure 4.2 -1: Safety Software Architecture**

The second software prototype differs from the first one in functionality, hardware and/or implementation details. (In the following just new functionality or updates are described.)

- Integration to new target hardware
- Setup of final development environment including adaptation of start-up procedure, linker script

- 
- Communication via UART (universal asynchronous receive transmit) between safety chips to make safe network communication possible (Both safety chips are involved in the communication process.)
  - Interface to EEPROM (required for storing error logs)
  - Monitoring of output voltage for over- and under-voltage
  - Hardware tests (RAM, ROM, CPU test) are checking integrity of hardware periodically
  - Support of safe network management commands (safe binding, ...)
  - Time synchronization between safety chips
  - Reading safe inputs and writing safe outputs, testing of safe input/output periodically

#### Software certification

In period 2 it was decided by the PMC to certify parts of the software. For that reason a detailed functional safety management, thorough testing and extensive documentation is necessary. Related to the requirements the following work was necessary.

- Writing of functional safety management document
- Reviewing of existing documents from other project partners
- Document software requirements specification, software architecture and test case specification with requirements tracking included
- Test plan that covers the different test methods and techniques
- Implementation and execution of white box test cases to test safe communication between nodes and safety chips.

In addition to the work mentioned before the following work was done:

- (1) Specification, implementation and test of a Shortstack API equivalent called Safety Chip Orion Stack (SCOS). Required for Loytec LC3020 platform
- (2) Network access layer: Functionality included for SCOS
- (3) Specification of installation tool for Shortstack and LC3020 platform.
- (4) Automated test software for checking functionality of Neuron and LC3020 core modules.

The following challenges were discovered and must be solved during the remainder of the project::

- Adaptation of Orion Stack running on LC3020
- Optimization of system regarding memory resources and performance
- Cooperation between node software and PC tools

During Period III three software prototypes were created and released to the members of the consortium. All of them are integrated into the safe main module (target hardware) in combination with a Neuron FT3120 core module or LC3020 core module. Software prototypes were based on the other prototypes developed in Period 2. They were increased in functionality and existing software components were updated or adjusted to new requirements. The final prototype integrates all software modules presented in Figure 4.2-1.

In detail, the results of Period III are the following:

- Communication interface is the Shortstack from Echelon or LC3020 from Loytec, and Shortstack API or Safety Chip Orion Stack API running on Safety Chip 1 that enables exchange of safe network variables between nodes (a driver running on Safety Chip 1 for communication was created).
- Development of safe library on LC3020 to handle communication with Safety Chip 1
- Commands of Shortstack API and Safety Chip Orion Stack API, respectively, are encapsulated in functions of the network access layer
- Interface to EEPROM (required for storing error logs)
- Monitoring of output voltage for over- and under-voltage
- Hardware tests (RAM, ROM, CPU test) are periodically checking the integrity of hardware
- Monitoring of software function to detect failures due to software aging

- 
- Sending and receiving of safe network variables (NV)
  - Support of safe network management commands (safe binding, ...)
  - Time synchronization between safety chips to perform jobs in close cooperation
  - Reading safe inputs and writing safe outputs, testing of safe input/output periodically
  - Scheduling based on a static and sequential scheduling mechanism
  - State machine including a specific start-up procedure to guarantee safety of the node during start-up, a safe state in case of a failure and a modify state used during configuration and maintenance of the node

In addition, the following work was done:

- (1) Test case specification created
- (2) System tests of a safe node according to the test specification
- (3) Documentation of test results
- (4) Update of documentation of software architecture and requirements specification
- (5) Review of SAFETYLON tool document created by WP3.2
- (6) Integration of applications created by WP4.3 to the safety operating software
- (7) Knowledge transfer of members of WP2 to the SMEs in a two-day workshop
- (7) Support of SMEs by creating their demo applications in WP5

### **4.2.3. Dissemination activities**

Dissemination activities are separated into two parts: scientific publications and work in standardization committees to bring safety in automation to standardization.

#### (1) Scientific publications

Ph.D. thesis

- § T. Novak. Functional Safety and System Security in Building Automation and Control Systems – A Common Approach. Ph.D. thesis, Vienna University of Technology, Institute of Computer Technology, Austria, Vienna, 2008 (to be published).

Diploma thesis

- § B. Sevcik. Netzwerkzeitsynchronisation in sicheren Feldbussystemen. M.S. thesis, Vienna University of Technology, Institute of Computer Technology, Austria, Vienna, 2007.
- § P. Preininger. Hardware Selftests For Safety Critical Fieldbus Nodes. M.S. thesis, Vienna University of Technology, Institute of Computer Technology, Austria, Vienna, 2006.

Papers

- § T. Novak, T. Tamandl. Architecture of a safe node for a fieldbus system. In Proceedings of the 5th IEEE International Conference on Industrial Informatics, Vol. 1, pp. 101-106, 2007.
- § T. Tamandl, P. Preininger. Online Self Tests for Microcontrollers in Safety Related Systems. In Proceedings of the 5th IEEE International Conference on Industrial Informatics, Vol. 1, pp. 137-142, 2007.
- § T. Tamandl, P. Preininger, T. Novak, P. Palensky. Testing Approach for Online Hardware Self Tests in Embedded Safety Related Systems. In Proceedings of the 12th IEEE International Conference on merging Technologies and Factory Automation, pp. 1270-1277, 2007.
- § T. Novak, B. Sevcik. Network Time Synchronization in a Safe Automation Network. In Proceedings of the 7th IEEE International Workshop on Factory Communication Systems, pp. 305-313, 2008.
- § T. Novak, P. Fischer, M. Holz, M. Kieviat, T. Tamandl. Safe Commissioning and Maintenance Process for a Safe System. In Proceedings of the 7th IEEE International Workshop on Factory Communication Systems, pp. 225-232, 2008.

#### (2) Standardization activity

A draft standard was submitted to the European standardization body CEN, Technical Committee 247, Working Group 4. The draft standard includes a lot of ideas and practical information gained during the work in the SAFETYLON project.

---

Members of the ICT have been involved in the development of the draft standard and in fruitful discussions with other members of the community. The intention of the draft standard is to standardize a set of requirements that must be met during the development and use of a safe and secure building automation and control system.

### **4.3. Work Package 3: Development of Tools (P. Fischer/M.Mentzel, FH Dortmund)**

#### **4.3.1. Objectives**

Work package 3 of the SAFETYLON project ‘Development of tools’ aims to provide software solutions for embedded development, installation, configuration and test tools.

##### **4.3.1.1.WP 3.1 Enhancement and Modification of Existing Development Tools**

It is very important that SME and OEM developers will feel very familiar with the enhancements and modifications of the development tools that are required because of safety reasons according to the IEC 61508 standard to reach a broad market acceptance for device and system manufacturers. This is all the more important because the RTD partners have decided to use ARM 7 type controllers for embedded safety implementations within this project. Therefore the standard LONWORKS development tools like NodeBuilder from Echelon can only partially be used within the complete embedded development process in combination with reliable development tools for the safety controllers.

The sustainability of the overall project results and the commercial opportunities are strengthened by further objectives within the sub work package. The definition of safe functional and communication profiles within LONMARK International and the national LONMARK organisations has to be initiated and established. On European level the standard EN 14908 will be extended by a further part describing the SAFETYLON technology. This ensures investment protection for all internal project partners, and – in the future – for licensees from the European manufacturing industry.

##### **4.3.1.2.WP 3.2 Development of Installation and Configuration Tools**

The market acceptance for system manufacturers and integrators very strongly depends on the installation and configuration process in the field. Therefore the basic objective is to use the “normal” and today commercially available tools as far as it is possible according to the IEC 61508 standard. Of course, enhancements are needed but these will be implemented as add-ins or plug-ins for existing tools – all based on the LNS database platform from Echelon.

##### **4.3.1.3.WP 3.3 Development of Safety Function Testing Rules, Procedures and Tools**

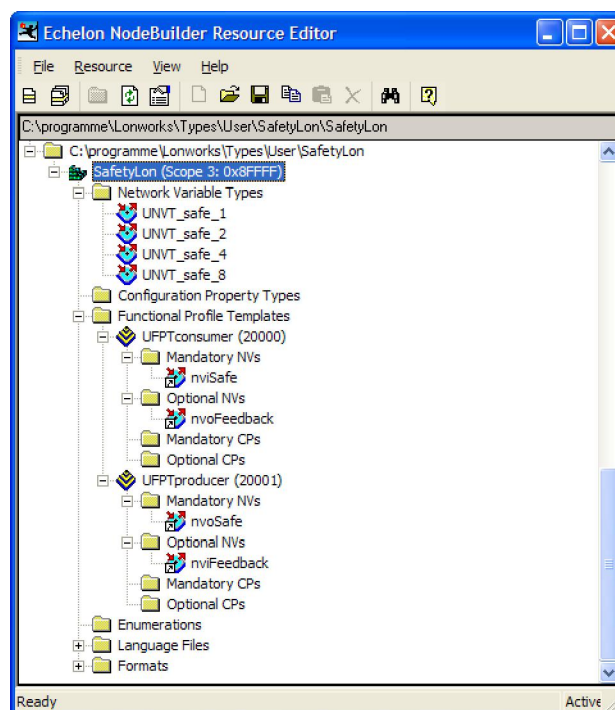
Rules, procedures, and tools for testing are very important for the verification and validation process during the development of safe systems and devices and the making of products. They have to cover additional tests that are normally not performed by TÜV within the device type approval. The primary objective is the development of a set of tools to be used by accredited test laboratories together with the test bed developed in work package 5.9 which allows testing of the device after completion of the TÜV device type approval for getting a product certified by an authorized certification body. Therefore these tests are only related to functional and network communication testing respectively. The secondary objective is to provide self-testing tools for SME partners and OEM developers to verify and validate their own development process and to prepare their products for the above mentioned tests.

## 4.3.2. Results

### 4.3.2.1. WP 3.1 Enhancement and Modification of existing Development Tools

With the document “Proposal for the implementation of LONMARK Standard Network Variable Types (SNVTs) for SAFETYLON” the foundation for the ongoing work has been established.

The specification of LONMARK profiles with SAFETYLON SNVTs has been established. The generic LONMARK Device Resource Files (LDRFs) have been developed. As the SME application development is an ongoing process it is expected that specific LDRFs will be developed by individual SMEs on the basis of the generic LDRFs.



**Picture 4.3-1: LONMARK Device Resource Files for SAFETYLON Technology**

The LONMARK Task Group for safety applications has been founded and established within the LONMARK International organization. A mirror Task Group has also been founded within the LONMARK Germany organization. Currently, generic and more application specific functional profiles are developed and synchronized between the national and international groups. Moreover, the LONMARK organizations and Task Groups are supporting the marketing strategies of the IAGs.

Initially caused by the necessary decision to use ARM7 and not EIA709 CPUs for the first safe channel and during inspection of the ARM7 embedded development tool chain further missing links have been detected in this chain. The basis for defining the LONWORKS network interface for a new SAFETYLON application is the ShortStackWizard or ShortStackBuilder API for ShortStack based developments and the ORION stack development environment for ORION stack based developments. When defining the LONWORKS interface in these environments several files are generated for the support of either stack. But further files for the application development performed by SMEs or OEMs after the project are still missing. If those files would have been created manually it could result in mis-mappings of individual items and would make an application development more inconvenient, complex and error prone.

Therefore it has been decided to fill this gap with a common development tool for the SAFETYLON development tool chain called “SAFETYLON Application Builder”. This software tool acts as a client to the underlying base development tools for ShortStack or ORION stack developments, generates the basic files for the stacks and additionally generates the required files for the application developments with the support of the defined SAFETYLON application API.

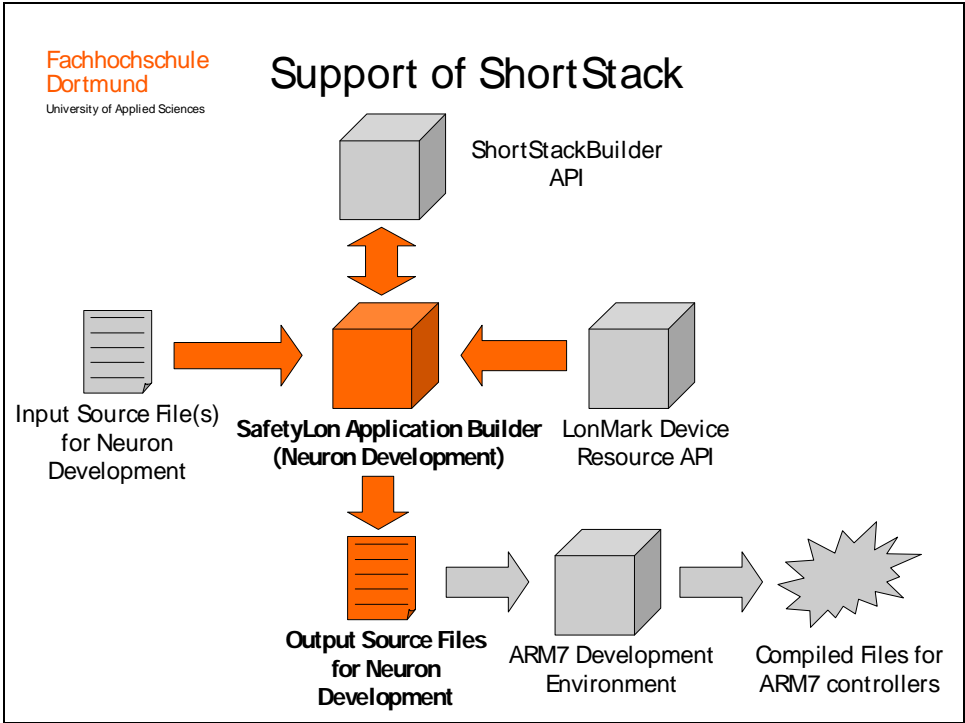
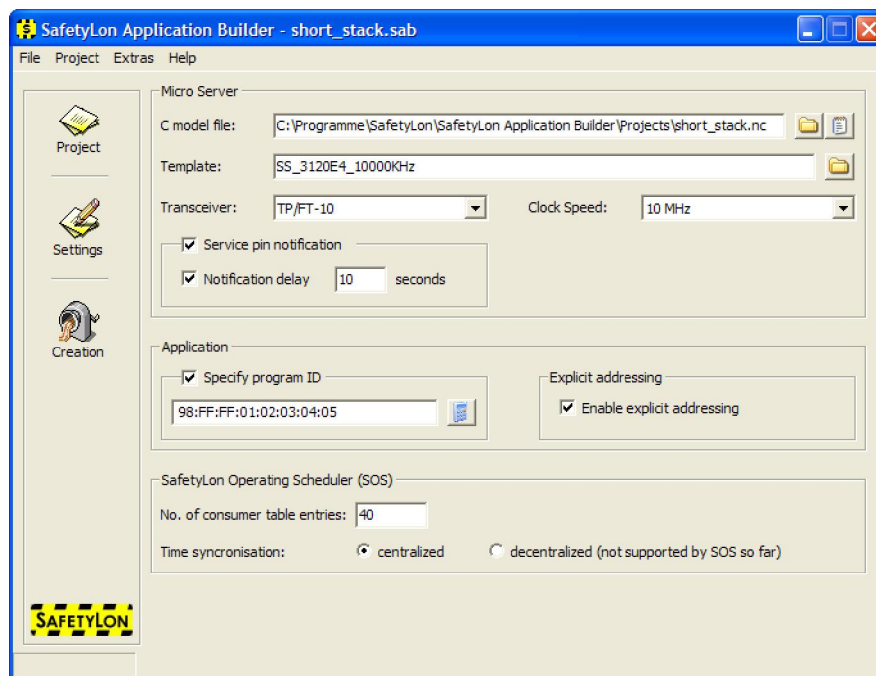


Figure 4.3-2: Flow Chart of SAFETYLON Application Builder



**Picture 4.3-3: Splash Screen of SAFETYLON Application Builder**



**Picture 4.3-4: User Interface of SAFETYLON Application Builder**

During the SME workshop dated May 3<sup>rd</sup> and 4<sup>th</sup>, 2007 the SAFETYLON Application Builder has been handed over to the SMEs together with a complete setup script to distribute the tool, samples and the specified LDRFs. Provided the SMEs are able to build their own application framework based on their currently existing non-safe applications.

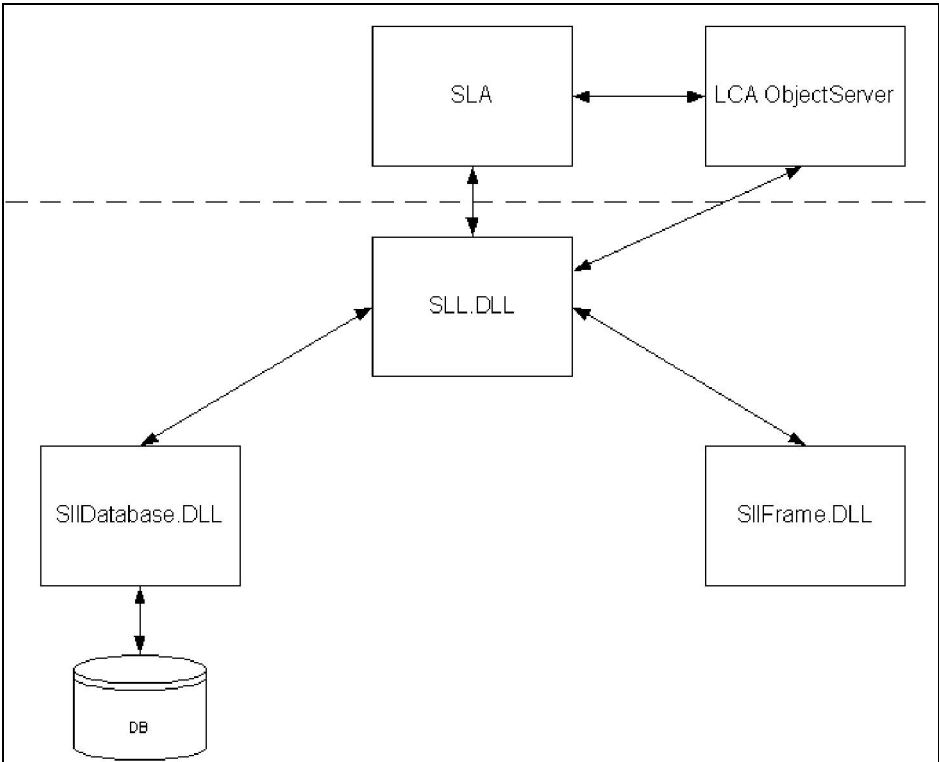
The knowledge transfer to the SMEs has been done in another workshop taking place on January 30<sup>th</sup> and 31<sup>st</sup>, 2008. Within this workshop all internal details of this tool software have been explained extensively. A detailed design description document persistently contains this knowledge transfer even for future industrial licensees.

**4.3.2.2.WP 3.2 Development of Installation and Configuration Tools**

The document “Specification of safety related Addressing, Binding and Configuration for “SAFETYLON” is the basis for the installation, configuration and maintenance process. The software requirement specifications for SAFETYLON installation and configuration tools have been finalized. Further, the detailed design description documents for this PC tool software which is partitioned into modules, has also been developed and finalized.

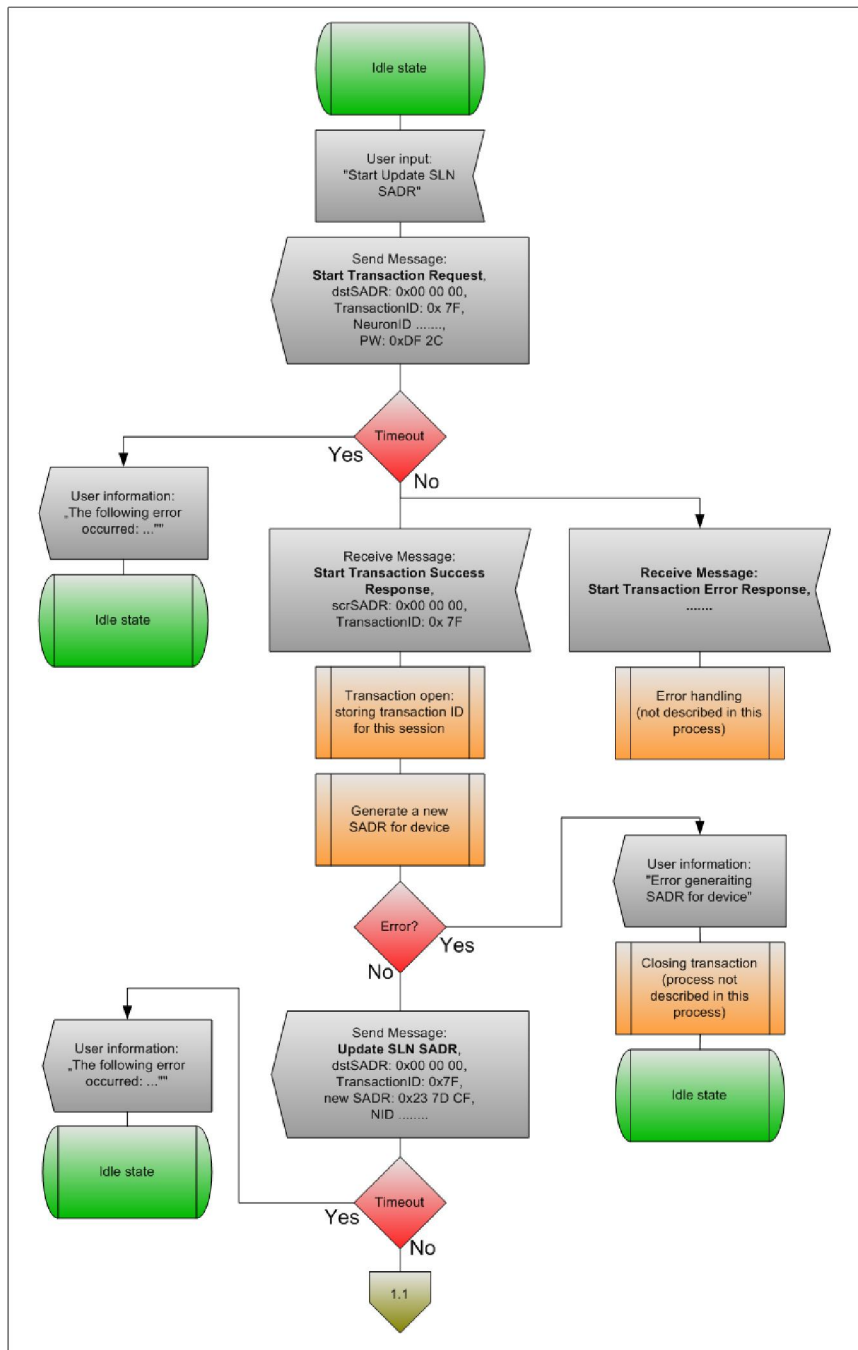
All required processes of safe installation and configuration have been described in detail in the document referenced above. As an example the first part of the commissioning process is shown in the following figures 4.3 – 5 to 4.3. -9.

The implementation of the module SAFETYLON Library (SLL) and the module SAFETYLON Application (SLA) has been commenced. While the SLL is the underlying network access layer with a COM (ActiveX) server API which supports all required methods for accessing and communicating with the safe devices the SLA is developed as a LNS Plug-In with a COM client API to access the API of the SLL.



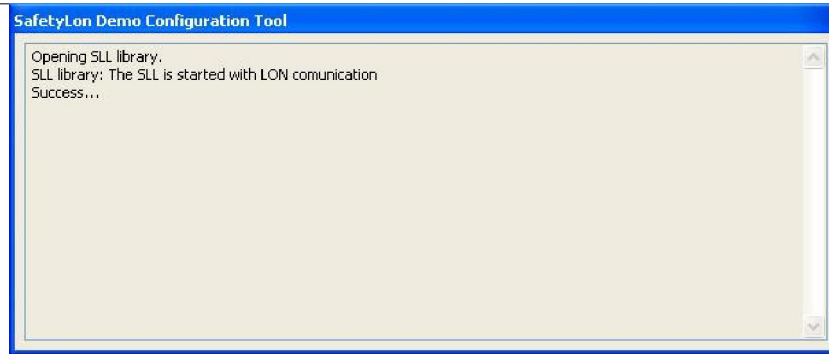
**Figure 4.3-5: Software Architecture of PC-Tools**

The following figure 4.3-6 shows the beginning of the commissioning procedure.

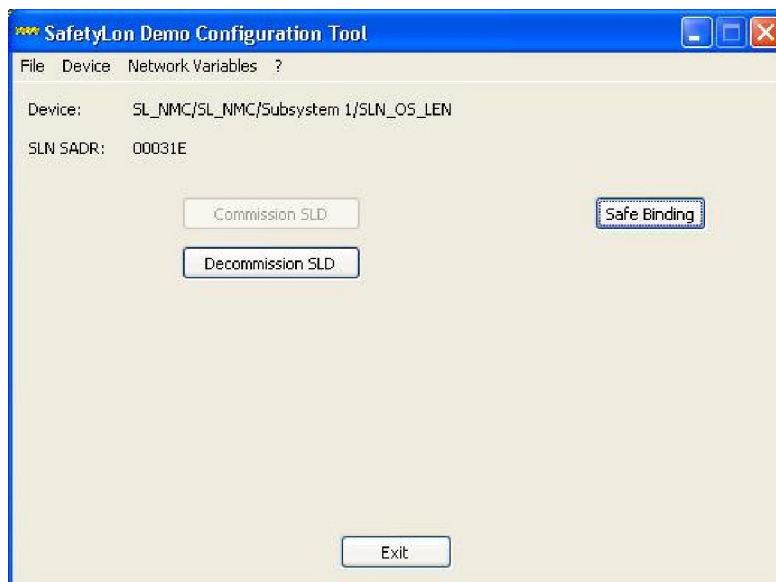


**Figure 4.3-6: Commissioning Process (Part 1 of 4)**

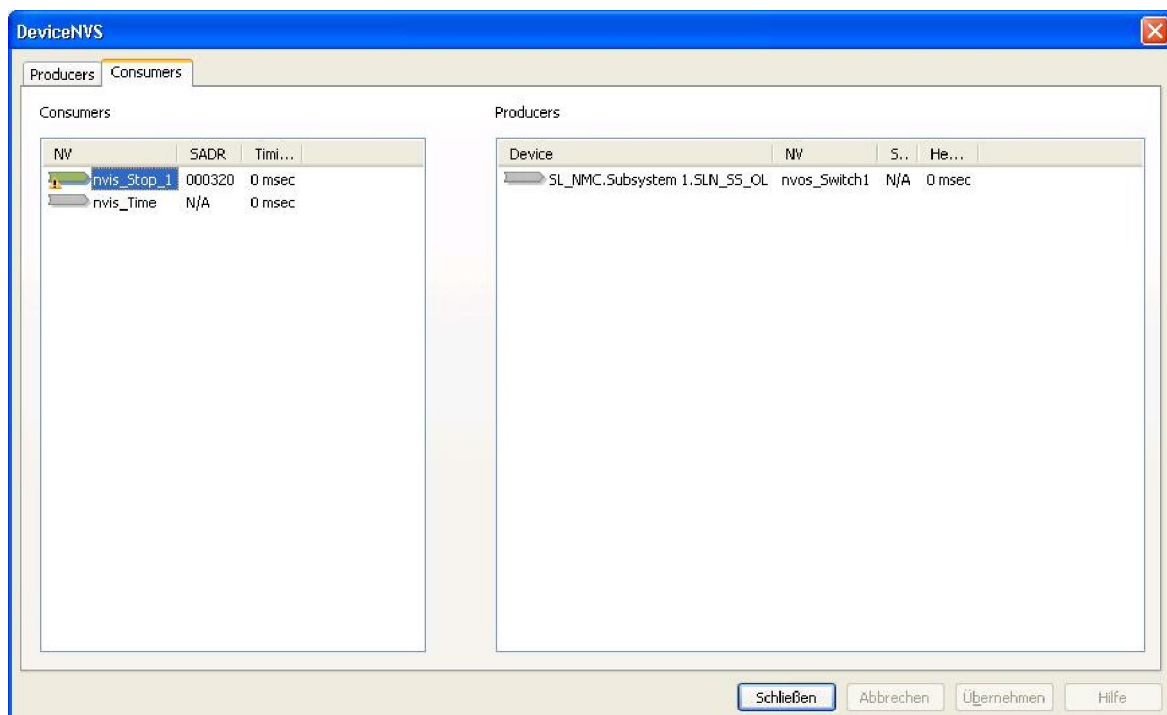
As an operator interaction is required to guarantee a safe process during installation, configuration or maintenance procedure the SLA, of course, has an user interface which is shown as an example in the following screenshots:



**Picture 4.3-7: SLA Log Window**



**Picture 4.3-8: SLA User Interface for Commissioning a Device**



**Picture 4.3-9: SLA User Interface for Creating a Safe Binding**

The partitioning of the software architecture into several modules guarantees low efforts on the side of internal partners of future OEMs when designing own installation and configuration tools (e.g. for OEM specific SafeLon systems). The SLL encapsulates all functionality to perform safe installation, configuration and maintenance according to the TÜV concept approval. To provide user interaction the SLA developed within this sub work package or an OEM specific SLA can provide the user interface. So an OEM can concentrate on the customer oriented field handling requirements while using the provided and underlying encapsulated library (SLL).

### **4.3.2.3.WP 3.3 Development of Safety Function Testing Rules, Procedures and Tools (Pawel Kwasnowski, AGH-UST)**

Corresponding to the overall project plan of the document “DoW V 1.0” sub work package 3.3 starts in month 14 of the SAFETYLON project. The first collection of ideas how to perform the testing has been made within the RTD panel and in WP3 meetings.

The development work for WP 3.3 is mainly performed by AGH-UST Krakow. Work has started in May 2006 and at the beginning was performed by AGH-UST permanent staff responsible for identification of problems and the development of concept and specification of testing requirements, tasks and methods. In this stage our work had to be supported by project partner Innotec as a specialist company experienced in safety related systems. After the meeting in Krakow on December 12, 2006 between AGH-UST team and Mr. Michael Kieviet from Innotec, the final requirements for our testing task were defined and specified in project documents (document 8 – see list of developed documents). After the analysis of possibilities it was also decided to apply LabView environment and TestStand software from National Instruments for testing purposes and additionally RTH data base for the definition of tests, test parameterisation and reporting of results. There are two main arguments for such a development decision:

1. The LabView environment is a well recognized professional software and hardware accepted by TÜV,
2. The necessity of using advanced tools to speed up the development process of testing.

Works performed by the WP 3.3 team in the second reporting period include:

- Participation in the definition of requirements and specification (WP 1),
- Participation in monitoring of current progress of hardware and software development (WP 2, WP 3),
- Definition of requirements and specifications of test tools for black boxes testing of the safety layer (WP 3.3),
- Development of specification documents for black box testing (WP 3.3)
- Development of black box testing methodology and environment (WP 3.3)
- Establishing a group of programmers working on test environment programming (WP 3.3).
- Development of testing environment in LabView and Test Stand programming tools and development of test design and recording of test results in a RTH database (WP 3.3).

Documentation generated:

(1) Overview of Techniques Required for Different Phases of Safety Lifecycle Model according to IEC 61508 Standard v.4 – 2006.12.15, 115p.

(2) Overview of testing techniques specified in IEC 61508 Standard v.4 – 2006.12.15, 60 p.

#### **4.3.2.4 WP 3.3 Development of Safety Function Testing Rules, Procedures and Tools (Pawel Kwasnowski, AGH-UST)**

Due to Consortium decisions regarding the scope of testing required by TUV for conformance testing, WP3.3 tasks were widely extended.

A List of all activities taken within WP 3.3 is presented in :

Deliverable **D12 Part 1 - General Descriptions**, Section 1: WP3.3 Chronological Work Report (11 pages)

***4.3.2.4.1. Development of a SAFETYLON Node Simulator for first tests of SL communication.***

***4.3.2.4.2. Development of tests of SL communication.***

***4.3.2.4.3. Development (Design, programming and testing) of a SAFETYLON Test Suite - Automatic testing environment for black box testing of SAFETYLON nodes communication and safe behaviour of hardware and software according to IEC 61508 standard. SAFETYLON Test Suite is based on LabView, Test Stand and rth database. Altogether there were released 7 versions of Test Suite software.***

Below all activities related to development of the SAFETYLON Test Suite are presented

#### **4.3.2.5. SAFETYLON Test Suite Development**

| <b>Date</b>                                | <b>Activity</b>  |
|--|--|
| 28.05.07 – 06.06.07                        | Designing and creating subVIs to using TestStand Engine to automatically executing sequence files.   |
| 12.06.07 – 25.06.07<br>27.06.07 – 20.07.07 | Creating and testing subVIs to using TestStand Engine to automatically executing sequence files, adding these vis to SLonTestSuite and testing of execution. |
| 10.05.07 – 07.08.07                        | Implementing of GUI, modification of modules for SLL commands tests  |
| 08.08.07 – 10.08.07                        | Implementing of time synchronisation modules (Time Slave) – external applications  |
| <b>10.08.07</b>                            | <b>Testing SLN time synchronisation features (Time Slave).</b>   |
| 13.08.07 – 17.08.07                        | Implementing of test steps for SLL commands tests (using final structure)  |
| <b>17.08.07</b>                            | <b>Testing SLL commands of SLN (basic ones)</b>  |
| 20.08.07                                   | Documentation of time synchronisation vi's (Time Slave).   |
| 21.08.07                                   | Implementing of Time Server in GUI   |
| 23.08.07                                   | Test sequences for Time Slave synchronisation tests and basic SLL commands   |
| 27.08.07 – 28.08.07                        | Creating Time Server service in SLonTestSuite.   |
| 28.08.07                                   | Testing SLN: time sync. (Time Slave) and basic SLL commands  |
| 31.08.07                                   | Modification of test reports (including detailed report and protocol analyser report)  |
| 03.09.07 – 13.09.07                        | Defining of SLL tests in rth   |
| 17.09.07                                   | Implementation of application message, new commands in document: SDD_Safe Layer Library of PC Tool_V0_4_intermediate.doc.                                    |
| 20.09.07 – 25.09.07                        | Updating of test modules for SLL tests according to document: D_SDD_Safe Layer Library of PC Tool_V0_4_intermediate.doc.                                     |

|                            |   |
|----------------------------|---|
| 26.09.07 – 03.10.07        | Testing SLN, modification of synchronisation frame (data field has 4 bytes).  |
| 04.10.07                   | SLN Testing with BBT_0006_001 application: Time Slave sync. and SLL commands  |
| 05.10.07 – 08.10.07        | Extension of GUI, performance tests<br>Implementation of SLTS Release Manager application.                                  |
| 09.10.07                   | Modules for Time Master synchronisation tests.  |
| 12.10.07 – 16.10.07        | Migration of SLL frames handling to LabView   |
| 17.10.07                   | Verification of test modules implementation   |
| 18.10.07 – 19.10.07        | Inspecting SLL database structure and contents  |
| 25.10.07 – 30.10.07        | Further development of SLTS Release Manager   |
| 23.10.07 – 07.11.07        | Implementation of modules and definitions for SLL tests. Implementation of VSLN to test modules                             |
| 07.11.07                   | Testing SLN with BBT_006_001 application.   |
| 08.11.07                   | Modification of REQUEST command reporting. Development of SLL modules   |
| 09.11.07                   | Testing of SLNs with SLL tests  |
| 12.11.07 – 16.11.07        | Further developments of SLL tests (modules and definitions)   |
| 13.11.07 – 16.11.07        | Further development and tests of SLTS Release Manager   |
| 16.11.07                   | Testing of SLN with ICT_071131 application (SLL).   |
| 16.11.07 – 21.11.07        | Extension of time synchronisation tests   |
| <b>21.11.07 – 23.11.07</b> | <b>Testing of SLN with time synchronisation tests (SLN_AGH_0007).</b>   |
| 27.11.07 – 27.11.07        | Further development of time synchronisation tests   |
| 28.11.07 – 03.12.07        | Further developments of SLL tests (modules and definitions)   |
| 02.12.07 – 04.12.07        | Programming interface to SLL database.  |
| 04.12.07 – 20.12.07        | Modifications and extensions of SLTS GUI  |
| 21.12.07                   | Testing of SLN SLN (synchronizacja, SLL).   |
| 27.12.07 – 29.12.07        | Programming interface to SLL database.  |
| 02.01.08                   | Update of SLL modules to include VerificationID field   |
| 02.01.08 – 04.01.08        | Testing interface to SLL database and creating additional functions.  |
| 03.01.08 – 10.01.08        | Modification of definitions and sequences for SLL tests   |
| 08.01.08 – 09.01.08        | Testing interface to SLL database and creating additional functions.  |
| 11.01.08 – 15.01.08        | Extension of SLTS GUI   |
| 12.01.08 – 25.01.08        | Further development of interface for SLL database, development of prerequisites which act on SLL database                   |
| 16.01.08 – 18.02.08        | Implementation of modules and definitions for SLL tests which use SLL database  |
| 25.01.08 – 30.01.08        | Creating vi's to perform hardware tests.  |
| 01.02.08 – 04.02.08        | Extension of SLL database interface, development of SLL database prerequisites  |
| 04.02.08 – 11.02.08        | Creating vis to perform hardware tests.   |
| 11.02.08 – 15.02.08        | Additional functions in SLL database API, testing of SLTS and SLTS Release Managera   |
| <b>18.02.08</b>            | <b>Testing of SLN (SOS_080130).</b>   |
| 18.02.08 – 10.03.08        | Design, implementation and testing of power supply modules, definitions of power supply tests in rth, sequences development |
| 19.02.08 – 04.03.08        | Development of modules and definitions for SLL tests  |
| 05.03.08 – 06.03.08        | Documenting SLL tests (user documentation)  |

|                     |  |
|---------------------|--|
| 06.03.08 – 18.03.08 | Technical documentation for SLL commands test modules  |
| 19.03.08            | Testing SLN with SOS_080307  |
| 10.03.08 – 30.04.08 | <b>Development and testing of vi modules for Safe IO tests, development of test sequences and rth test definitions</b> |
| 19.03.08 – 02.04.08 | Technical documentation for SLL commands test modules  |
| 03.04.08 – 11.04.08 | Technical documentation for time synchronisation test modules  |
| 14.04.08 – 16.04.08 | Technical documentation for modules used in SLTS engine  |
| 16.04.08 – 28.04.08 | Testing SLN with SOS_080307, update of SLL test modules  |
| 28.04.08 – 30.04.08 | Technical documentation for modules used in SLTS engine  |
| 05.05.08 – 08.05.08 | Testing of SLN with SOS_080430.  |
| 09.05.08 – 15.05.08 | Technical documentation for modules used in SLTS engine  |
| 19.05.08            | Technical documentation for functions in DLL library   |
| 20.05.08 – 23.05.08 | Update of project documents.   |

**Table 4.3 – 10 List of activities related to the development of the SAFETYLON Test Suite**

#### **4.3.2.6. Published SAFETYLON Test Suite Releases**

Below dates of publication (i.e. some party requested particular publication) are given for various parts of testing work:

| <b>Date</b> | <b>Publication</b>                      |
|-------------|---|
| 2008-01-18  | rth with SLTS and Release Manager       |
| 2008-01-23  | update of SLTS Release Manager          |
| 2008-01-30  | update of SLTS                          |
| 2008-02-15  | update of rth i SLTS                    |
| 2008-02-19  | test applications for SLN               |
| 2008-02-25  | schematics for hardware tests           |
| 2008-04-24  | update of schematics for hardware tests |

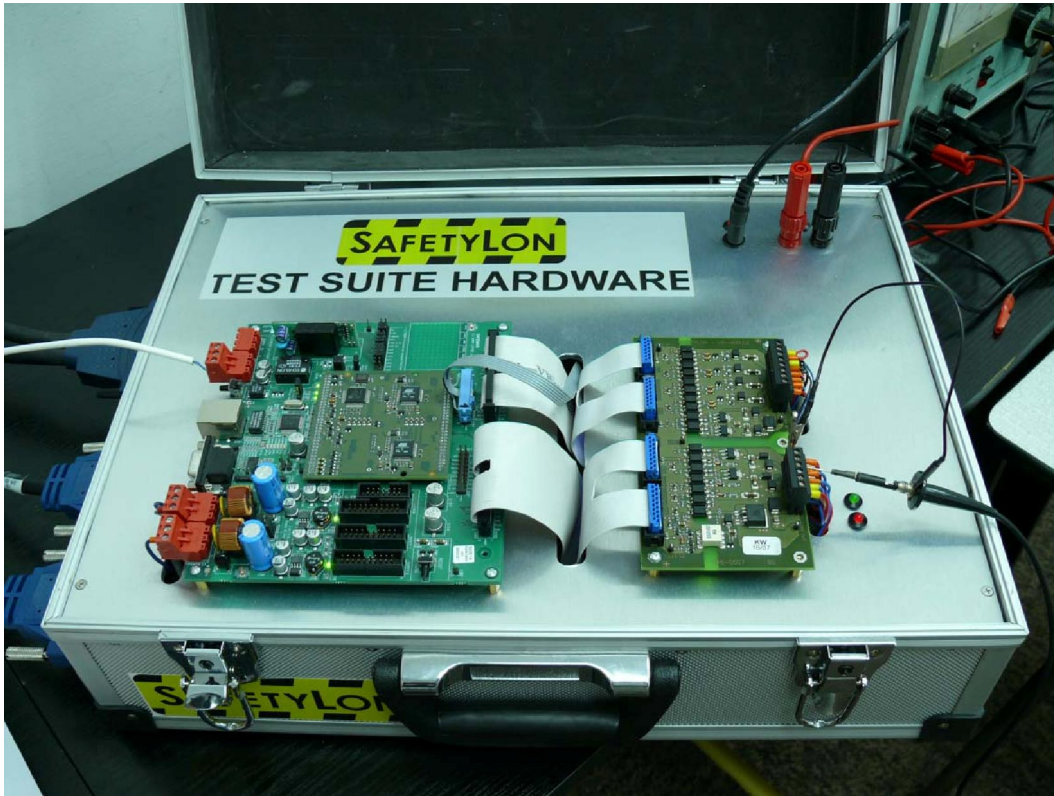
**Table 4.3 – 11 Special Testing requests with dates performed**



**Picture 4-3-12 SAFETYLON Test Suite Laboratory Stand**



**Picture 4-3-13 SAFETYLON Test Stand Details**



**Picture 4.3-14 SAFETYLON Test Suite Hardware**

Wide and detailed description of SAFETYLON Test Suite concept, hardware and software is presented in

**D12 Part 1 - General Descriptions**

Section 2: SLTS System Architecture – 18 p

Section 3: SLTS Installation Guide – 9 p

Section 4: SLTS User's Guide – 40 p

Section 5: SLTS Technical Reference – 170 p

**4.3.2.7.** Testing of updated releases of SAFETYLON Operating Software (SOS) and SAFETYLON Library (SLL)

**4.3.2.8** In total four releases of SOS and seven releases of SLL. Published SAFETYLON Test Suite Releases were performed. Altogether 1.124 tests of SAFETYLON node software and hardware were executed and documented. .

| <b>Date</b>               | <b>Remarks</b>   | <b>Tests</b>   |
|---------------------------|--|--|
| 2007-05-10                | No heartbeats, no time sync, no SLL  | 16 May – Executing Safe Communication test SLN – all tests failed ( <b>63</b> tests)   |
|                           |  | SLL and time sync were not tested.   |
| 2007-07-11                | Still no heartbeats, no time sync, no SLL                                  | several basic SLL tests – tested device replies too late (timeout in grey-channel) ( <b>8</b> tests)   |
|                           |  | time sync -Time Slave (exists but doesn't work as expected)  |
|                           |  | 16 – 21 August 2007 – adding Time Stamp service to VLSN (vis to Safe Communication tests), first tests with Time Stamp (tests failed), ( <b>21</b> tests)  |
|                           |  | 3, 4 September 2007 – executing Safe Communication test and report generating o SLN - tests failed, no heartbeats ( <b>42</b> tests, <b>2</b> schedule),   |
|                           |  | 5, 6 September 2007 – executing Safe Communication test and report generating on SLN - tests failed, no heartbeats ( <b>42</b> tests, <b>2</b> schedule),  |
| 2007-09-17                | First unreliable heartbeats, no timesync, first SLL commands, SLL_SDD_v0.4 | several basic SLL tests have Passed results, change of message transfer service to application message ( <b>7</b> tests),  |
|                           |  | Time Slave sync – exists but doesn't work as expected  |
| 2007-10-31                | First time sync, few more SLL commands                                     | first modification SLL commands in SLN – replies from SLN are in old format (SLL SDD v0.4), Set SLN SADR command doesn't change safe address of SLN ( <b>6</b> tests)  |
|                           |  | Time master synchronisation – after termination of requests, SLN sends synchronisation frame (response) filled with 0. Time master replies only in case where it's time differs not more than some value (about 60000). If the time difference is bigger, Time Master SLN does not replies |
|                           |  | Time slave sync – SOS (SLN) time goes 10% faster than real time clock; i.e. in SLN time passes 5s where real time clock shows 4.5s   |
|                           |  | 21, 22, 23 November 2007 – executing Safe Communication tests on SLN – first heartbeats, Time Stamp services turn off ( <b>63</b> tests),  |
|                           |  | 27 November 2007 – executing Safe Communication tests on SLN – first heartbeats, Time Stamp services turn off ( <b>21</b> tests),  |
|                           |  | 28 November 2007 – executing Safe Communication tests on SLN with Time Server – test failed ( <b>21</b> tests),  |
|                           |  | 30 November 2007 – executing Safe Communication tests on SLN with Time Server and checking value Time Stamp ( <b>6</b> tests, passed),   |
|                           |  |  |
| 2007-12-03,<br>2007-12-07 | SLL updates  | 21.12.07 – SLL tests – failed ( <b>48</b> tests),  |
|                           |  | 21.12.07 – Time synchronization tests – failed ( <b>11</b> tests),   |
|                           |  | 21.12.07 – Safe Communication tests on SLN with Time Server and checking value Time Stamp – failed ( <b>21</b> tests),   |
|                           |  | 04.01.08 – SLL tests – failed ( <b>4</b> tests),   |
|                           |  | 07.01.08 – SLL tests – failed ( <b>6</b> tests),   |
|                           |  | 08.01.08 – SLL tests – failed ( <b>3</b> tests),   |
|                           |  | 14.01.08 – Time synchronization tests – failed ( <b>9</b> tests),  |
|                           |  | 22, 23 January 2008 – executing Safe Communication test – test failed ( <b>10</b> tests),  |

|            |  |   |
|------------|--|---|
| 2008-01-30 | SLL commands added/updated, EEPROM safe storage  | 15.02.08 – SLL tests – failed ( <b>17</b> tests), Time synchronization tests ( <b>4</b> tests),   |
|            |  | 18.02.08 - Executing Safe Communication tests for SLN – ID header bit error not recognized ( <b>92</b> tests), SLL tests ( <b>26</b> tests), Time synchronization tests ( <b>20</b> tests), |
|            |  | 19.02.08 – SLL tests ( <b>6</b> tests),   |
|            |  | 20.02.08 – SLL tests ( <b>8</b> tests),   |
|            |  | 25, 26, 28.02.08 – SLL tests ( <b>8</b> tests),   |
|            |  | 19 – 28.02.08 – testing Power Supply tests ( <b>20</b> tests),  |
|            |  | 3 – 7.03.08 - testing Power Supply tests (vis, sequence files, RTH ) ( <b>40</b> tests),  |
|            |  | 2008-03-07  |
|            |  | 11, 17.03.08 – 3.04.08 – testing Safe IO tests ( <b>20</b> tests),  |
|            |  | 15.04.08 – SLL tests ( <b>9</b> tests),   |
|            |  | 16.04.08 – SLL tests ( <b>16</b> tests),  |
|            |  | 17.04.08 – SLL tests ( <b>20</b> tests),  |
|            |  | 21-23.04.08 – SLL tests ( <b>12</b> tests),   |
|            |  | 24.04.08 – SLL tests ( <b>23</b> tests),  |
|            |  | 9–25.04.08 – testing Safe IO tests,   |
|            |  | 25.04.08 – SLL tests ( <b>13</b> tests),  |
|            |  | 28.04.08 – SLL tests ( <b>4</b> tests), Time synchronization tests ( <b>4</b> tests),   |
|            |  | 28–30.04.08 – executing hardware test on SLN: Power Supply tests ( <b>12</b> tests), Safe IO Tests ( <b>8</b> tests),   |
| 2008-04-30 | SLL commands added/updated, Modify and Run State | 05.05.08 – SLL tests ( <b>53</b> tests), Time synchronization tests ( <b>4</b> tests),  |
|            |  | 06.05.08 – Power Supply tests ( <b>6</b> tests), SLL tests ( <b>11</b> tests), Time synchronization tests ( <b>13</b> tests),   |
|            |  | 07.05.08 – Power Supply tests ( <b>7</b> tests), SLL tests ( <b>50</b> tests), Safe IO ( <b>1</b> tests),   |
|            |  | 08.05.08 – Time synchronization tests ( <b>8</b> tests), Safe IO ( <b>15</b> tests),  |
|            |  | 09.05.08 – Safe Communication tests ( <b>46</b> tests) – ID Header bit error not recognized, Power Supply tests ( <b>11</b> tests), Safe IO ( <b>12</b> tests),                             |

**Table 4.3 -15 Series of Release Testing of SOS and SLL with dates performed**

**4.3.2.9 Deliverable D12 SAFETYLON Test Suite (SLTS) Documentation:****D12 Part 1 - General Descriptions**

- Section 1: WP3.3 Chronological Work Report – 11p
- Section 2: SLTS System Architecture – 18 p
- Section 3: SLTS Installation Guide – 9 p
- Section 4: SLTS User’s Guide – 40 p
- Section 5: SLTS Technical Reference – 170 p

**D12 Part 2 - Black Box Tests Reports Summary**

- Section 1: SLTS Black Box Tests Reports Summary – 553 p

**D12 Part 3 - WP 3.3 Extended Works – Test Cases VIs Documentation Reference**

- Section 1: A to GenerateInput Functions – 57 VI’s
- Section 2: GenerateReport to Q Functions – 108 VI’s
- Section 3: S to W Functions – 33 VI’s

**D12 Part 4 - WP 3.3 Extended Works – Executive VIs Documentation Reference**

- Section 1: SLTS Executive Functions – 77 VI’s

**D12 Part 5 - WP 3.3 Extended Works – SAFETYLON Test Suite Black Box Test Reports**

- Section 1: NB...SLN\_SOS\_080130\_AGH\_0011\_013
- Section 2: SLN\_SOS\_080130\_AGH\_0011\_014 ....  
SLN\_SOS\_080430\_AGH\_0011\_013
- Section 3: SLN\_SOS\_080430\_AGH\_0011\_022 ....  
SLN\_SOS\_080430\_AGH\_0011\_023
- Section 4: SLN\_SOS\_080430\_AGH\_0012\_000

**Legend:** p – pages. VI - LabView “virtual instrument” program

## **4.4 Work Package 4: Development of Interoperable Safety Modules**

(D. Loy/Loytec)

### **4.4.1. Objectives**

Work package 4 of the SAFETYLON project ‘Development of interoperable Safety modules’ aims to provide hardware modules for prototype and product development. In addition reference designs for specific application areas for the hardware modules should be provided to the SMEs. This report provides a compact survey of the objectives and results within the third period of the SAFETYLON project.

#### **4.4.1.1. WP 4.1 Neuron Based Module**

The first core module targets low cost network nodes with very low computing power. This module is based on the 8-bit Neuron Chip FT3120 from Echelon Corporation with limited CPU performance and small available memory resources. This module is named Neuron based module in the project plan. The development of this module has been performed by WHO. In addition an I/O board has been designed and implemented that offers 4 safe inputs and 2 safe outputs.

#### **4.4.1.2. WP 4.2 LC3020 Based Module**

The second core module targets more powerful applications that need CPU performance for controller applications and additional memory for logging and more complex computations. This module is based on the 32-bit *ARM7 LC3020* controller chip from LOYTEC with 50 MIPS CPU performance and 16 Mbytes of RAM and 8 Mbytes of FLASH memory. The development of this module has been performed by LOYTEC. In addition a mainboard has been designed and implemented that can either accommodate the Neuron based module or the LC3020 base core module.

#### **4.4.1.3. WP 4.3 Emergency Pushbutton and Logic Element Node**

An emergency pushbutton reference design and a logic element node with actuator output reference design have been developed. The emergency pushbutton was developed by WHO and the logic element node has been developed by LOYTEC. Both RTD developments served as templates and reference designs for the SMEs, both with regard to completeness and quality.

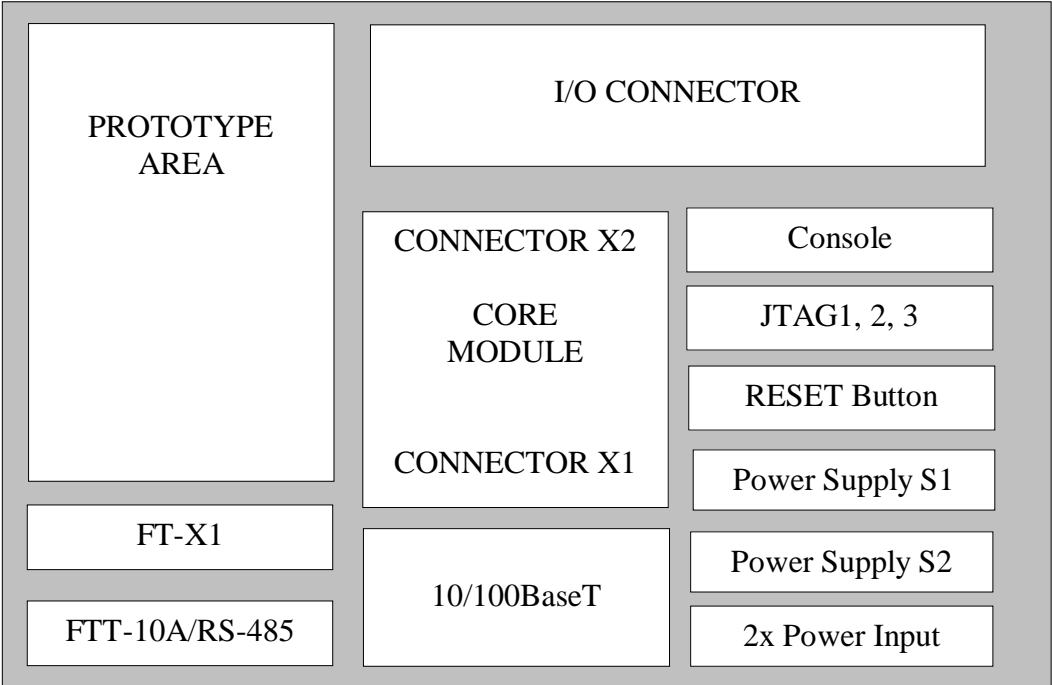
### **4.4.2. Results**

#### **4.4.2.1. Main PCB for Prototyping**

Since the two hardware designs from WP 4.1 and WP4.2 should be interchangeable when installed on a main board it has been decided to develop a common “main board” that can accept either the Neuron based module from WP 4.1 or the LC3020 based module from WP 4.2, and which can be used by the SMEs for prototyping their applications. The interchangeability has the great advantage that if somebody starts developing an application he can start the development with the lower performance Neuron based module and if the application is growing and requires more CPU performance, memory and more

communication power he can easily transfer his design to the more powerful LC3020 based module without changing his “main board”. All components common to the 2 module versions are located on the main board whereas the module specific components are installed on a daughter board that can be snapped onto the main board.

The block diagram for the SAFEMAIN board is shown in **Figure 4.4 - 1** .



**Figure 4.4 - 1: SAFEMAIN PCB for Prototyping**

The main board holds the 2 power supplies for the 2 safety chips and the Neuron FT3120 or LC3020 controller, the Ethernet port, the EIA-709 transceiver interface, a console connector, the connector to plug in the SAFE-I/O board and connectors to connect the JTAG interfaces for software download and software debugging.

**4.4.2.2 WP 4.1 and WP 4.2 Module Design**

The two technology specific modules are shown in Figures 4.4 -2 and 4.4 – 3 below. These daughter boards can be installed on the main PCB for prototyping. It is possible to either install the Neuron FT3120 based core module or the LC3020 based core module on the same main board. The technology specific modules include the CPU, memory, and the 2 safety chips. The safety power supply, connectors, debug logic are located on the main board. The safety I/O are located on a separate board.

The schematics have been designed and the boards have been built and successfully tested. Hardware kits have been distributed to the SMEs. A training session for SMEs has been held in Vienna, Austria.

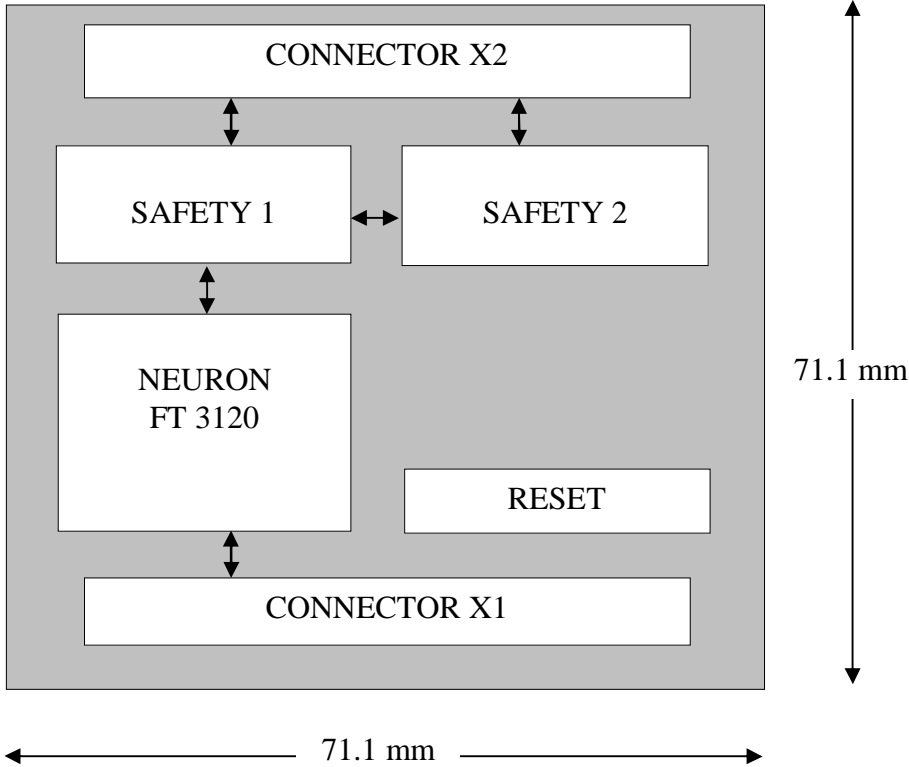


Figure 4.4 - 2: SAFETYLON Neuron based core module

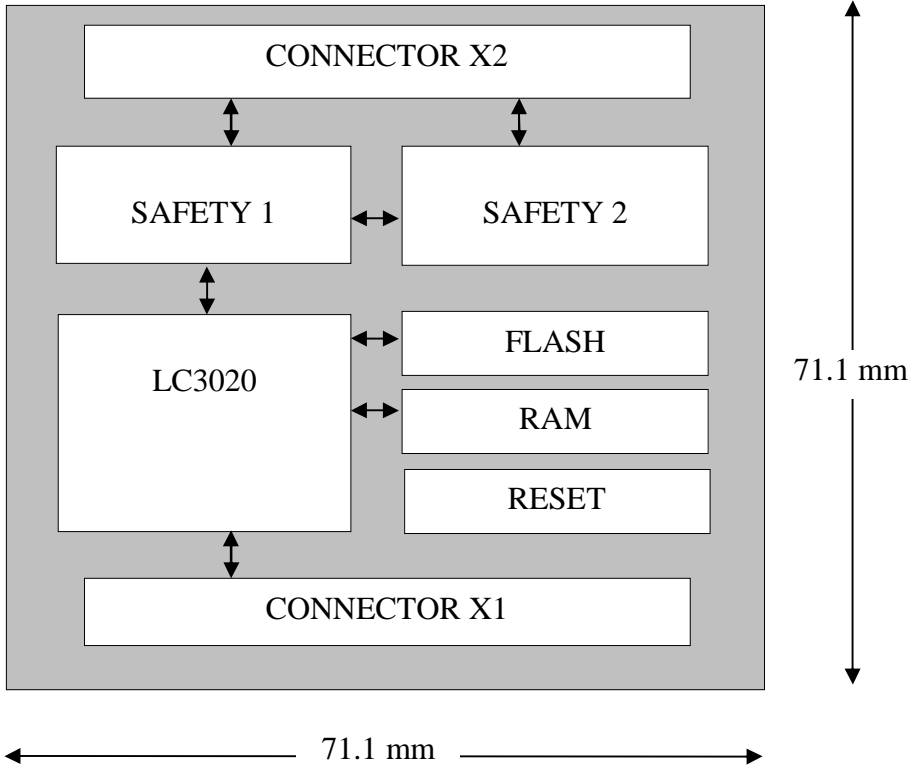
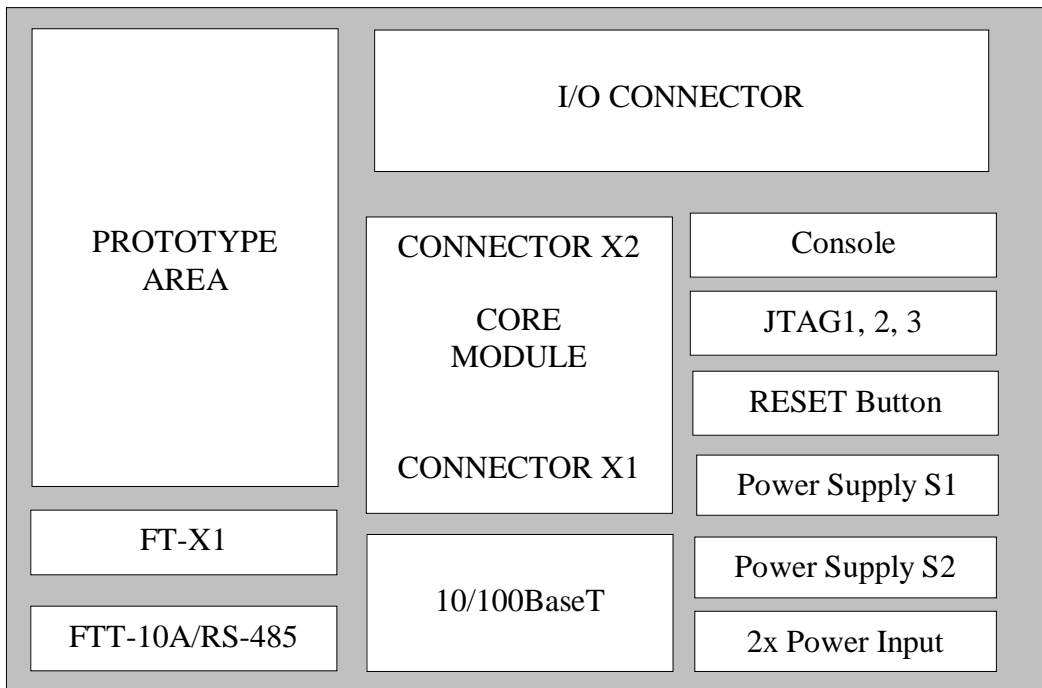


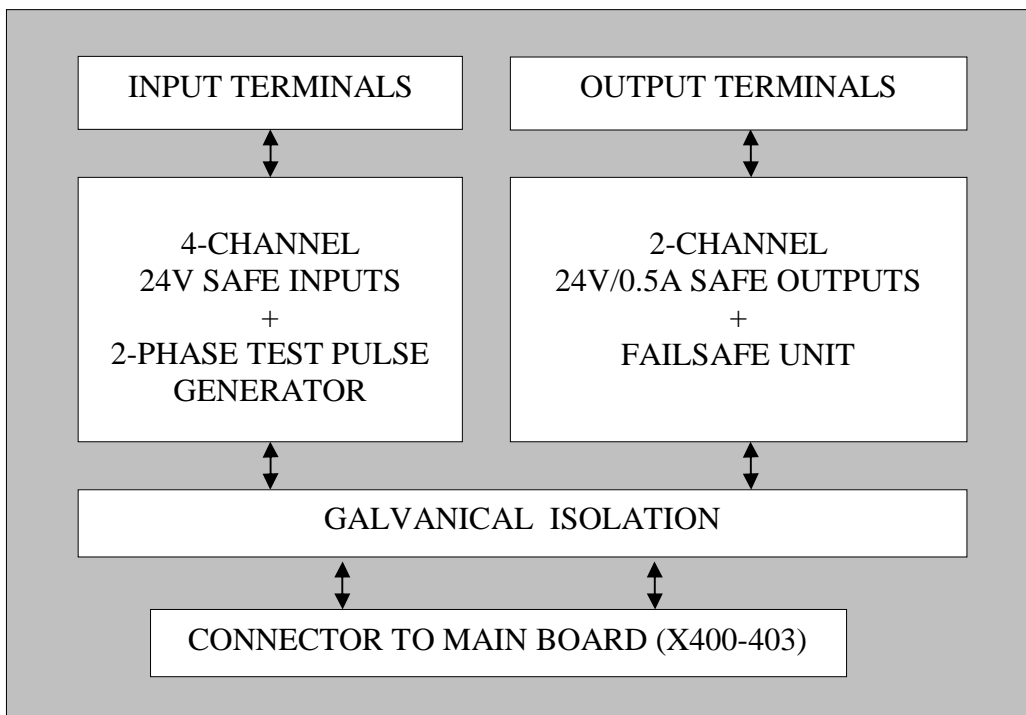
Figure 4.4 - 3: SAFETYLON LC3020 based core module

The SAFEMAIN main board can accept either the Neuron or the LC3020 based core module. The block diagram for the SAFEMAIN main board is shown below.



**Figure 4.4 - 4: SAFETYLON SAFEMAIN main board**

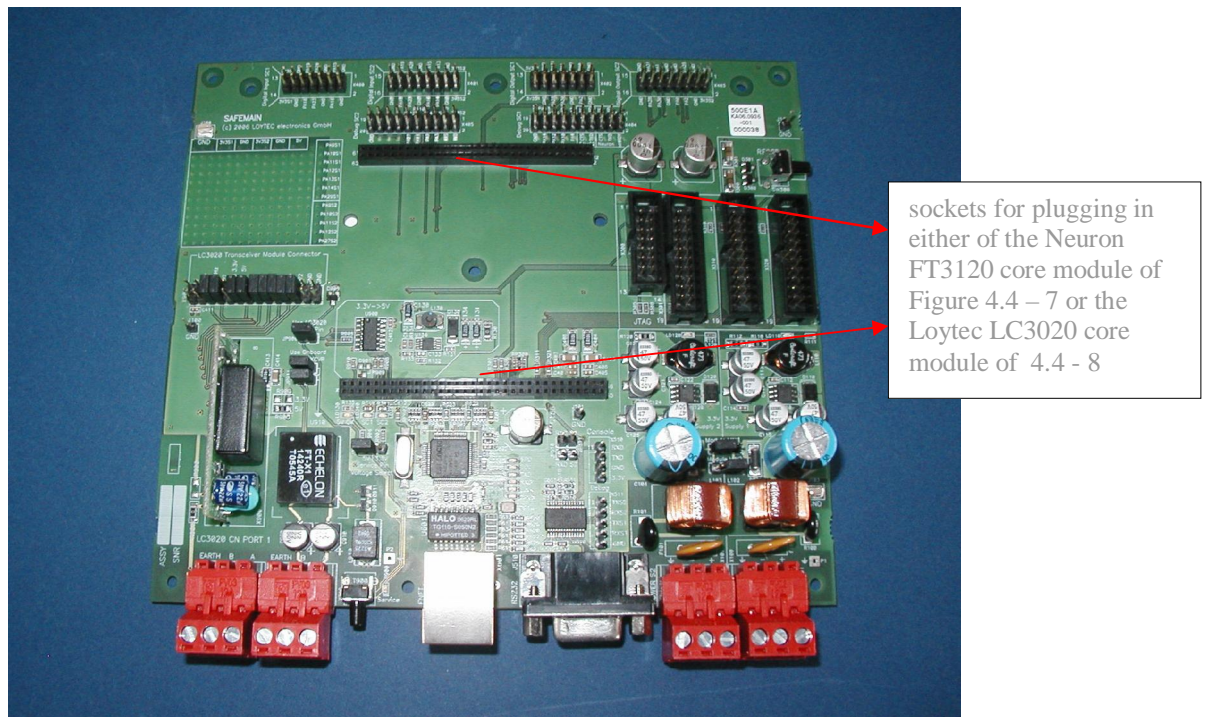
The Safe-I/O board that provides 4 safe inputs and 2 safe outputs is shown in the figure below.



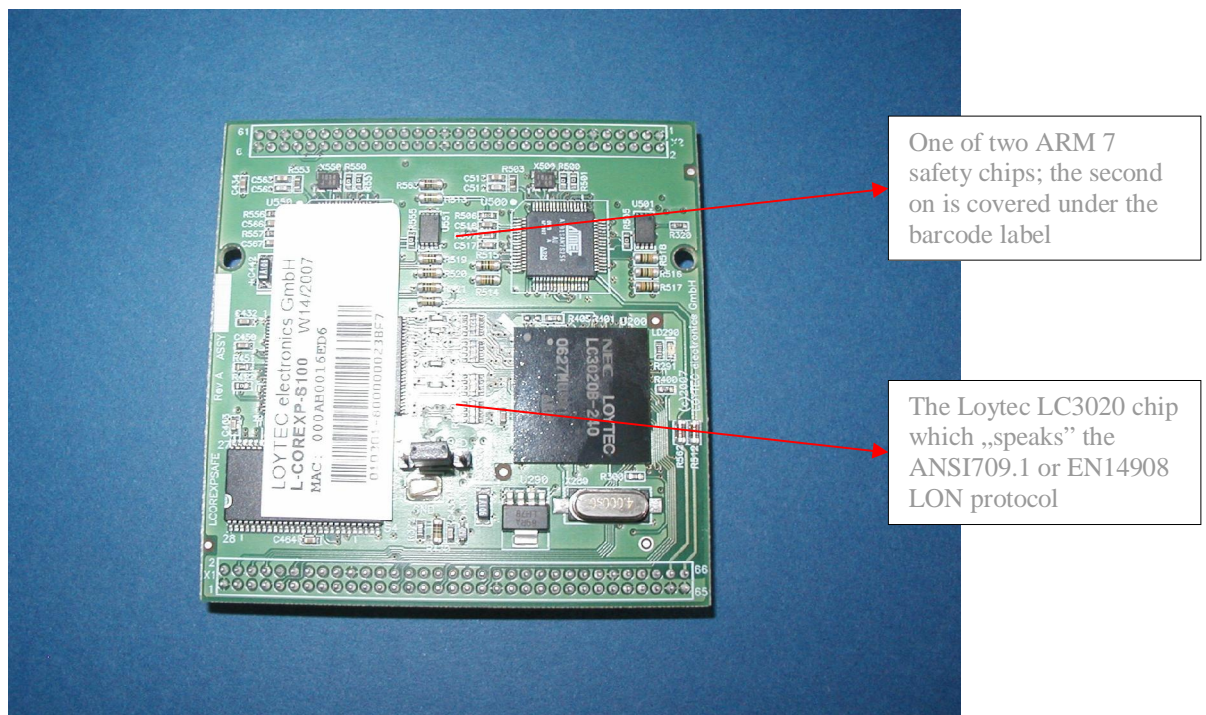
**Figure 4.4 - 5: SAFETYLON SAFE-I/O board**

Both the SAFEMAIN main board and the SAFE-I/O board have been built and successfully tested. Prototypes have been distributed to the SMEs.

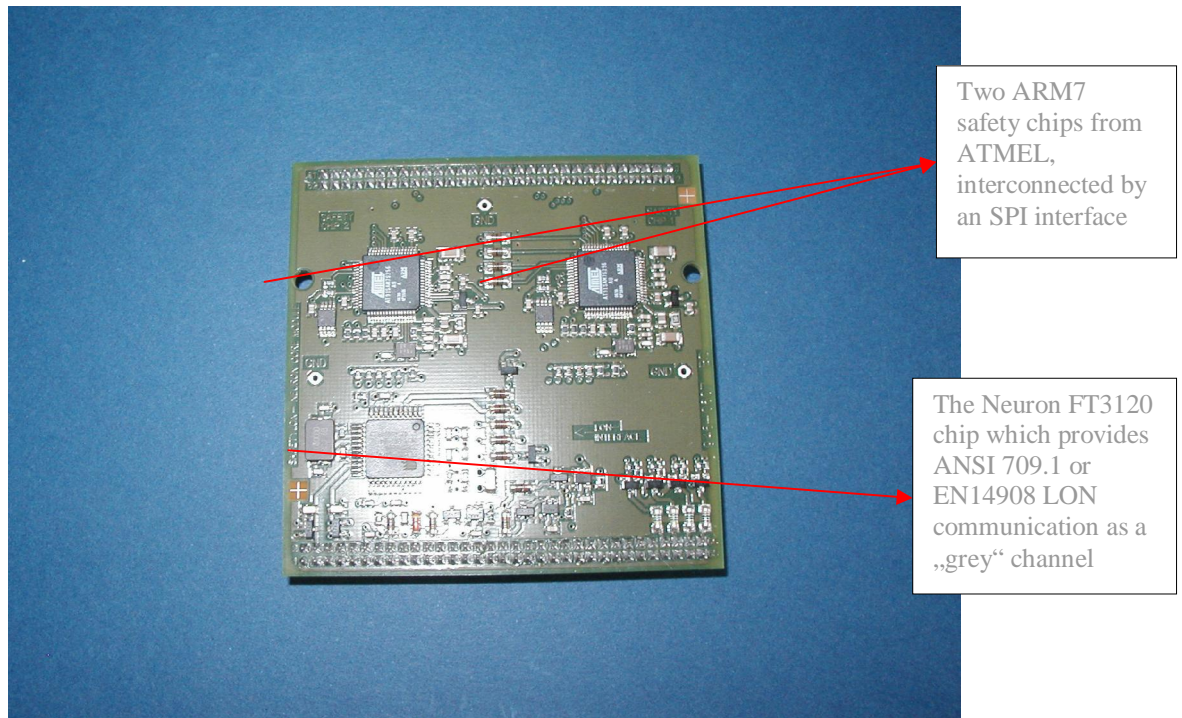
Pictures of the prototype boards can be found below.



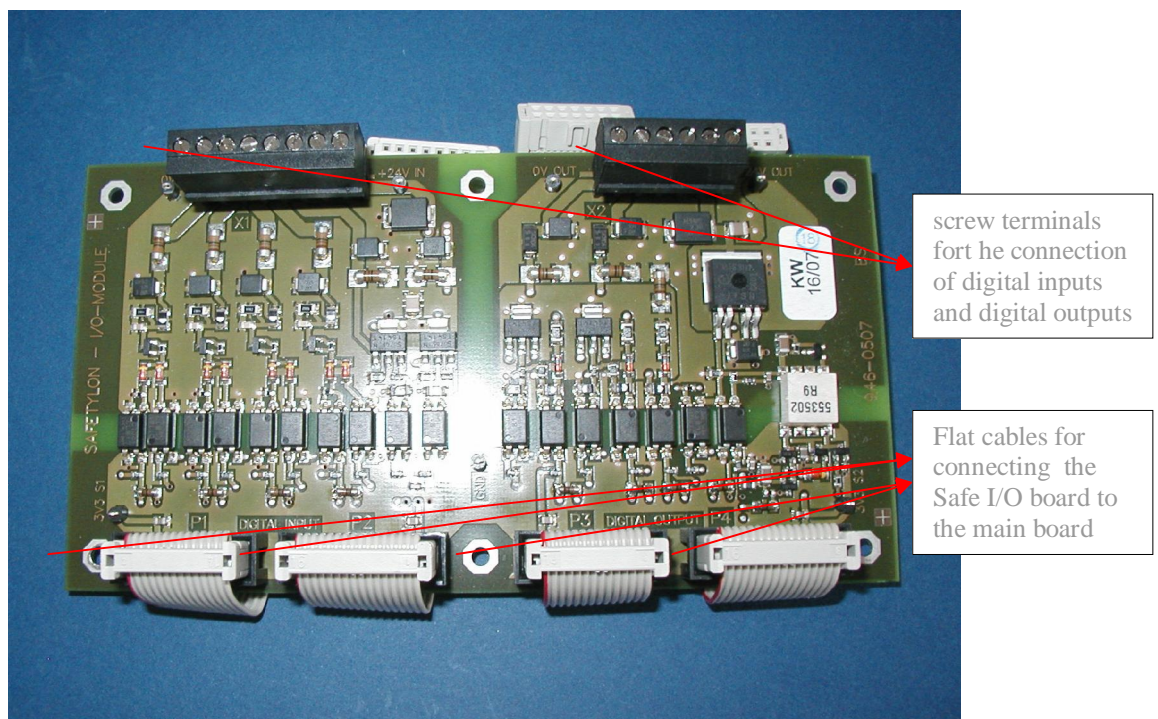
**Picture 4.4 – 6:** SAFEMAIN main board



**Picture 4.4 – 7:** LC3020 based core module



**Picture 4.4 – 8:** Neuron FT3120 based core module



**Picture 4.4 – 9:** SAFE-I/O board.

#### 4.4.2.3 Documentation generated

##### Hardware Specifications and Design [#20000]

- #20001, SAFETYLON Hardware Requirements Specifications V0.7, 2006-04-28
- #20002, Pin assignments for the safety chips V1.2, 2006-10-24

- 
- #20003, System Requirements Specification and System Design Description for WP4 Reference Design V1.2, 2007-04-18
  - #20100, Hardware Schematics, Parts Lists, PCB Layouts and Production Data
    - #20101, I/O-Board
    - #20102, Neuron Core Module
    - #20103, LC3020 Core Module
    - #20104, Main Board
  - #20200, PFD and PFH Calculations for Hardware

### **Software Specifications and Design (embedded) [#30000]**

- #30200, Application 'Emergency Push Button' (ShortStack based)
  - #30201, Software Requirement Specification and Design Description for Emergency Push Button Application V1.1, 2007-10-15
  - #30202, Source Code and Documentation for Application 'Emergency Push Button', Revision 1.0, 2007-10-21
- #30300, Application 'Logic Element Node'
  - #30301, Software Requirement Specification for Logic Element Node V1.0, 2007-12-07
  - #30302, Source Code for Application 'Logic Element Node', Revision 1.0, 2008-04-17

---

## **4.5. Work Package 5: Demonstration Applications (Ch. Brönnimann/IBT)**

Work package 5 of the SAFETYLON project ‘Demonstration Applications’ represents eight specific demonstration applications that are relevant for commercial SAFETYLON products to be developed at a later stage. Some of the initial plans have been changed due to improved knowledge on feasibility and specific requirements of certain applications. Further, it was judged to be of vital interest to develop experience in safety management level devices.

- (1) WP 5.1 Emergency lighting
- (2) WP 5.2 Elevator control
- (3) WP 5.3 Fire Damper Actuator, Safety Door and Escape Path Manager
- (4) WP 5.4 Fire detection and intrusion protection
- (5) WP 5.5 Emergency Exit Button
- (6) WP 5.6 Access control unit
- (7) WP 5.7 Fault indication and switch control panel
- (8) WP 5.8 SAFETYLON network management tool
- (9) WP 5.9 SAFETYLON test bed

### **4.5.0. Objectives and Description of Work Packages WP 5.1 to WP 5.9**

The period III was the busiest period for SME’s as they had to turn the RTD’s results into real applications. A major work had to be invested into the Functional Safety Management (FSM) process and the understanding of the quality procedures involved for Safety Application Development. As the deliverables of the RTD were delayed, a big effort had to be made on the part of the SMEs under significant time pressure, resulting in a further delay that could not be avoided. However, the prolongation of the total project helped.

In total six meetings (physical & teleconferences) and an additional workshop were necessary to coordinate the upcoming issues related to the design of the SME applications. In order to support the process, a standardized way of the software documentation and development structure had been introduced and recommended subsequently followed by most of the SME’s on a voluntary basis. Feedback towards the RTD’s was given in a systematic and organized way in order to improve the performance and functionality of the Safe Operating Scheduler software.

While, as expected, no market ready solutions were to be developed under the umbrella of this R&D project all SME’s could gain a lot of expertise regarding Functional Safety Management (FSM) and safety engineering which will become more and more important during the upcoming years. The system integration process has been identified as the critical step in system deployment, especially for an open systems solution approach like SAFETYLON..

A second, indirect advantage for SME’s was created by establishing an international network between the member companies generating other business relationships aside from this project.

### **4.5.1. WP 5.1 Emergency Lighting (IBT IngBüro Brönnimann, Thun, Switzerland)**

Note: Candelux left the consortium in agreement with the CM and the TPC and the SME IBT is going to develop the emergency lighting prototype after completion of Period II.

- **Objectives**

The objective is to develop an emergency lighting demonstration application using the Neuron based SAFETYLON module. The goal is to achieve a full, easy and nevertheless fail-safe integration of emergency lighting products into safe LON networks.

- **Description of Work**

IBT will implement SAFETYLON on the basis of third party products. In the demonstration model they will demonstrate emergency lighting in conjunction with the following modes: Monitoring and control of the emergency lights can be used in conjunction with alarm systems for signaling malfunctions or e.g. together with escape route management systems (see also chapter 4.5.3) to signal the escape route by switching the emergency lights in a safe way.

Test and monitoring of the function of each lamp is required to detect any malfunction in this installation powered by a self-contained power supply. The functioning of the battery packs is not part of the safe application; the safe application is the function and control of each single lamp.

**Note:**

Due to synergy effects, IBT has accepted this task on request by the PMC at less than half of the cost (compared to Candelux) in order to

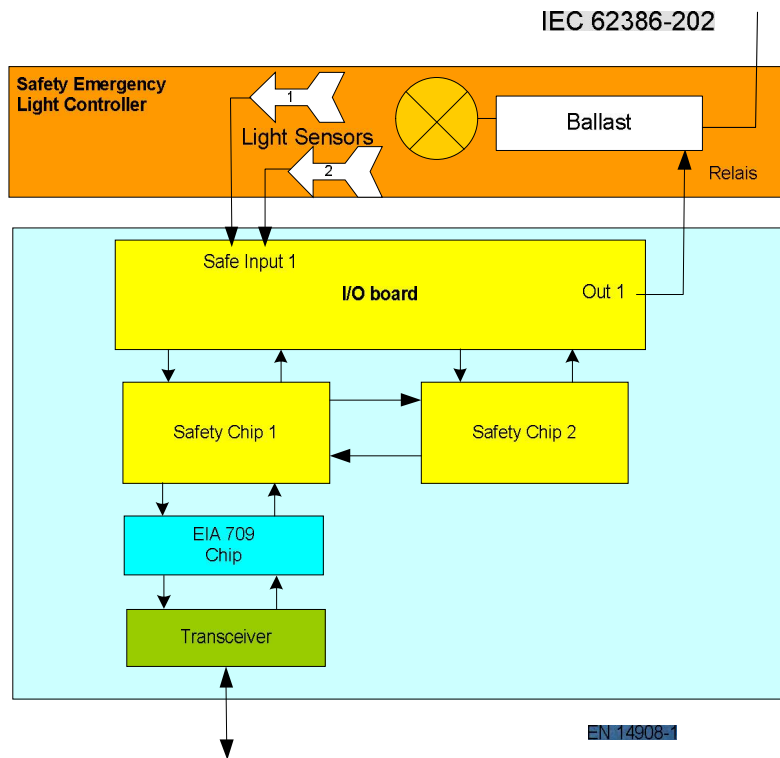
(a) provide a safe emergency lighting prototype node as planned in DoW V 1.0, and

(b) provide additional funding for the PMC to finance the higher than planned costs for TÜV type approval / certification.

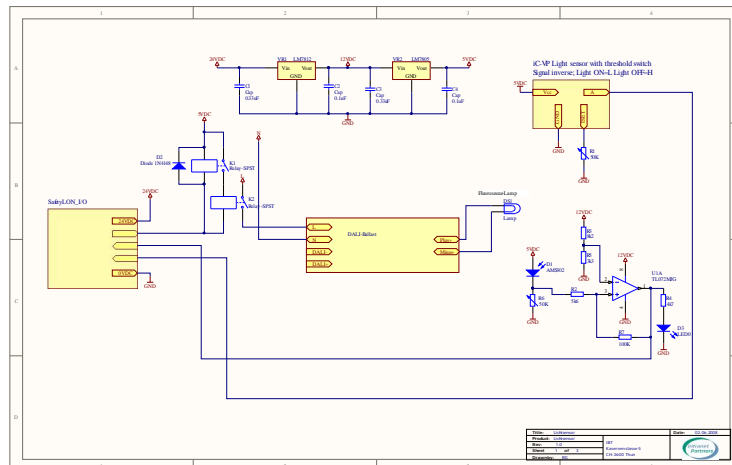
#### **4.5.1.1. Description of hardware extension**

An extension module was developed during period III. The field application node controls a *single safe lamp actuator*. The device supports sending and receiving commands and switch on /off functions of a safe light actuator, controlled by a dual ambient light (lux) sensor.

A remote DALI controller provides test cycles, acting as an emergency supply and dimming through its IEC 62386-202 (DALI) compatible ballasts.



**Figure 4.5-1 SAFETYLON node Safe Lamp Control**



**Figure 4.5-2 The Safe Lamp Control test device ...**

supports only a single safe lighting level threshold adjustable by potentiometers. The above schematic was applied within the test installation.

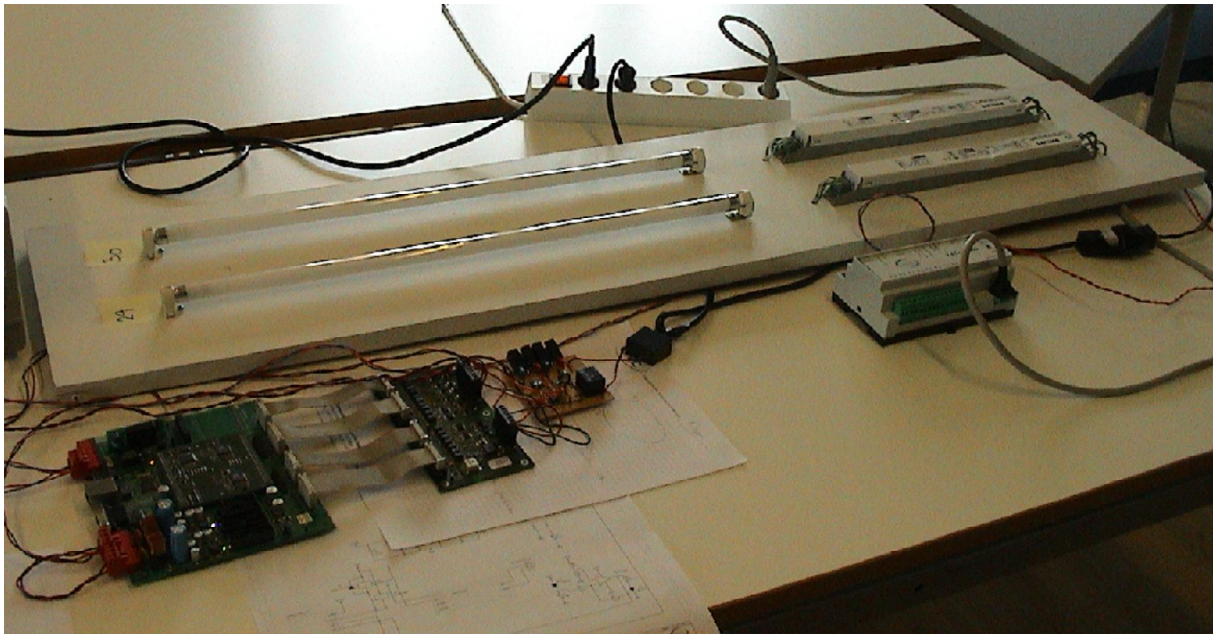
**4.5.1.2 Description of developed software**

This application monitors two two-channel lux level thresholds. It periodically samples the two safe inputs “Channel 1” and “Channel 2” and evaluates the state of comparators to be copied to the nvos\_LampReal. Each safe channel contains a dual binary input circuit. The two

binary inputs of each channel are interdependent. The state of the position detection switches is assumed to be “NOT ENGAGED” only if closed contacts are detected on both binary inputs. If on either binary input an open contact is detected, for safety reasons the state of the position switch is assumed to be “ERROR”. The output `nvos_Error` will then go to ON (100%/1) state.

#### 4.5.1.3 Functional test of developed software

The test equipment is based on two DALI lamp actuators and the ShortStack standard SAFETYLON modules. For test results, check the document *EscapePathManager\_V1\_0\_Release\_Notes.pdf*.



**Picture 4.5 - 3: The Lamp Actuator including DALI controller for testing purpose**

#### 4.5.1.4 Generated Documentation

The documentation is stored on the SAFETYLON internal server in the Demonstrator Applications directory:

```
Document Archive / Documentation / WP5 Demonstration applications / WP5.1 Emergency
Lighting
/ Release
EscapePathManager_V1_0_Release_Notes.pdf
/ Rev 1.0
/ Doc
ICT_Software_Prototype_070917_Description_v1.0_TN.doc
EmergLiDoxy_V1_0.xif (Doxygen Web with source SME_APP_FD_EmergLi_2008_05_10_V1.0_CB.pdf
(Application description, this file)
/ Sources EmergLight_V1_0.zip (directory with full workbench data)
```

## **4.5.2. WP 5.2 Elevator Control (INTRON GmbH & Co. KG, Germany))**

### **Objectives**

The objective of INTRON is the demonstration of a SAFETYLON application for industrial elevators and transport systems. The system to be developed will be a power-line based bidirectional data transfer system using SAFETYLON.

### **Description of Work**

The system architecture of the Elevator Control consists of a minimum of two nodes with bidirectional data exchange. The elevator control node receives a safe command and takes the appropriate action according to these commands. The position feedback selection will be based on redundant sensors. The prototype nodes will be based on FT communication. However, the final product will be converted to Powerline communication.

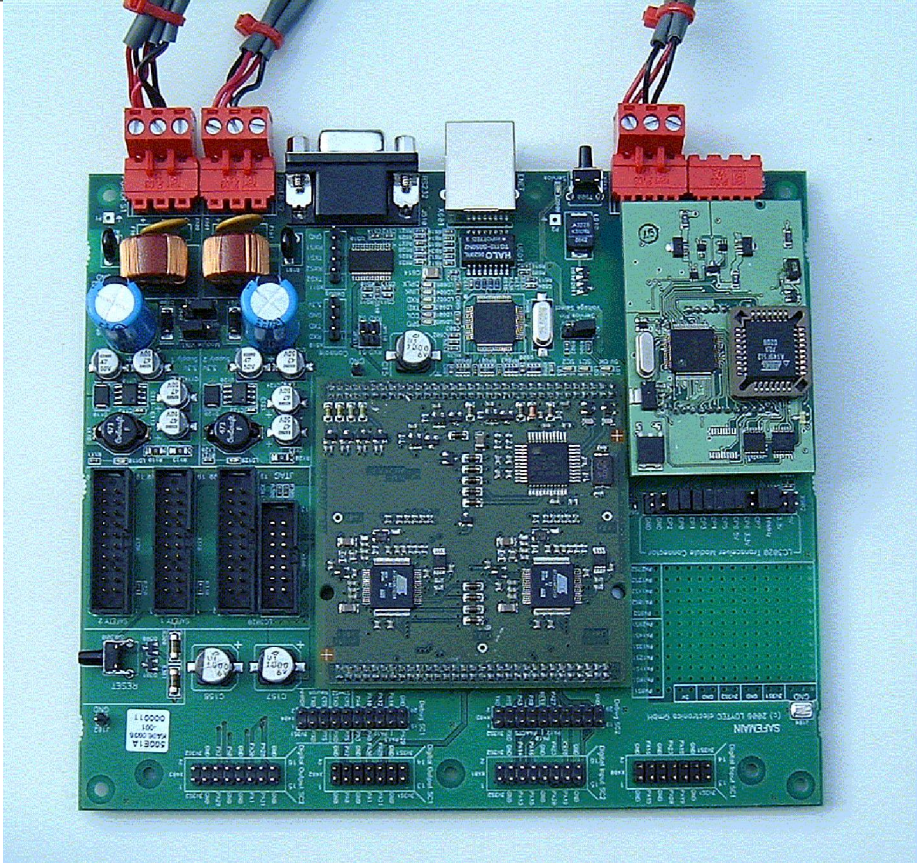
### **Details of PII**

Since the PMC had decided to not cover the Powerline channel within the scope of this project, Intron has spent considerable time to investigate the implications of this decision and has made plans to realize PL based modifications to the core modules (software) and to the design of an I/O board. Intron has participated in two SME workshops in Vienna and is now experimenting with the received SAFETYLON development kit.

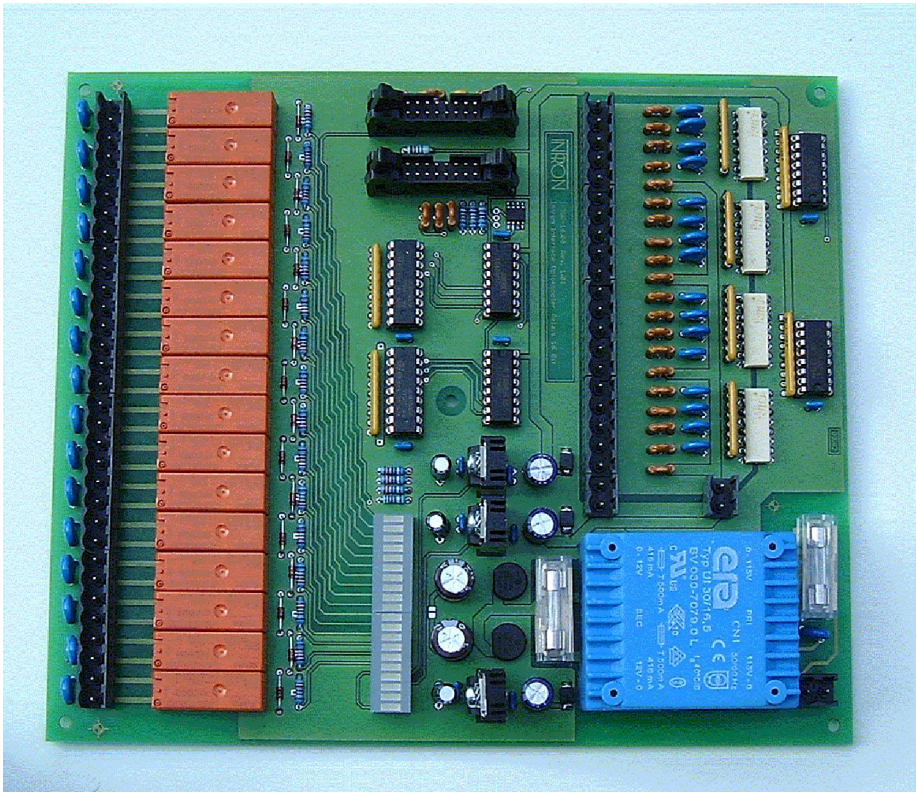
### **Details of Period III**

In Period III the PCB board has been redesigned with Powerline communication and is now available for test in November 2008. Afterwards it will be certified by TÜV. The software is then tested with a demo board, whereby the safety kernel stays unchanged. It was necessary to add additional non-safe I/O's, because an elevator control system normally needs more non-safe information in addition to the safety contact. Intron developed two I/O boards. One with 16 digital I/Os and one with ProfiBus DP interface.

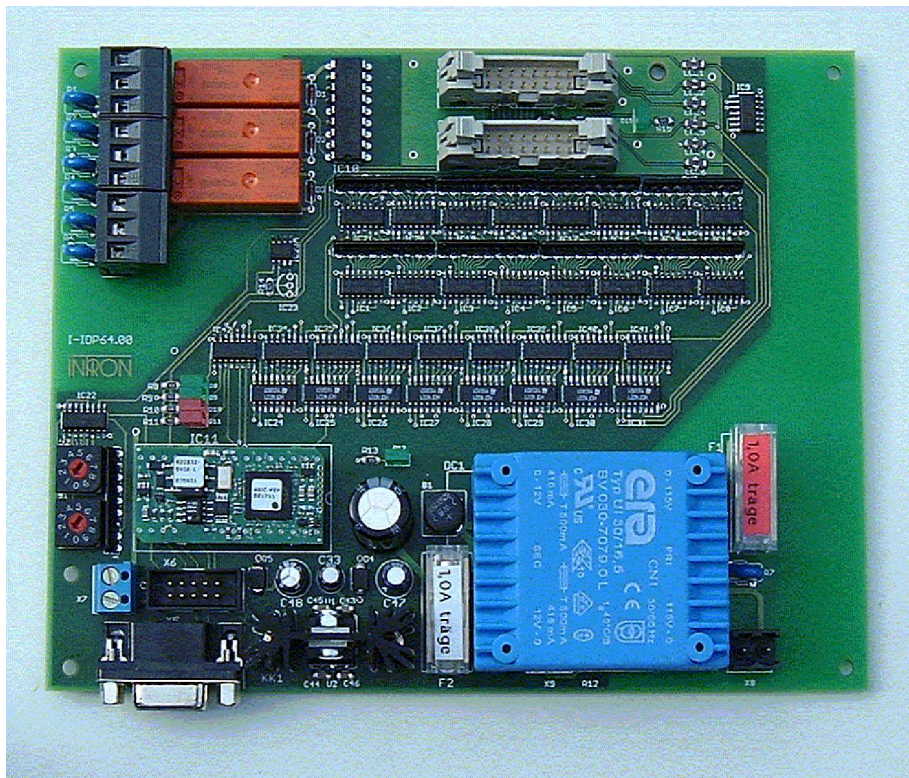
Below you can view pictures of the redesigned prototype and of the two I/O boards.



Picture 4.5 - 4 Board with Powerline module :



Picture 4.5-5 16 Bit Digital I/O-module :



**Figure 4.5-6 Profibus-DP Interface Board**

### **4.5.3. WP 5.3 Escape Route Management (IBT Ing.Büro Brönnimann, Thun, Switzerland)**

Note of Chris Brönnimann of IBT:

The substitution of train applications in WP5.3 as planned in the DoW V 1.0 was caused by the lack of interest of our main Swiss customer in an **open system** solution. Instead, an open system escape path manager / fire damper actuator / door manager system will be developed which even integrates emergency lighting and fire / smoke detectors. Our longtime knowledge of the building automation market supports our vision that our new concept offers a much higher market potential as well as opportunities for joint ventures with market leading companies. This substitution was proposed to and accepted by the PMC.

#### **Objectives**

IBT focused on three types of field devices: an automatic safety door controller (to be integrated by the Swiss door company “Record”) , a fire / smoke damper actuator (to be integrated by the Swiss company “Belimo”) and the Emergency lamp actuator developed in WP 5.1.

#### **Description of Work**

IBT implemented SAFETYLON applications into customer’s solutions fire / smoke damper actuator and automatic door. Within the scope of this work, IBT created demonstration solutions using NEURON PCBs. IBT’s goal was to prove its ability to support SAFETYLON Technology on an application level. The demonstration made available showed the principle functionality of an escape path manager but also the complexity of the system integration process. To address this issue market ready, 5 to 10 man years of additional development have been estimated being out of the scope of SME IBT.

#### **FSM Functional Safety Management**

The Functional Safety Management process requires a 16 Step procedure according the IEC 61508 standard. This process could only partially be integrated (step 1-5) but resulted in a better overall quality management of the IBT development process. This enhanced internal process is a major benefit for the company.

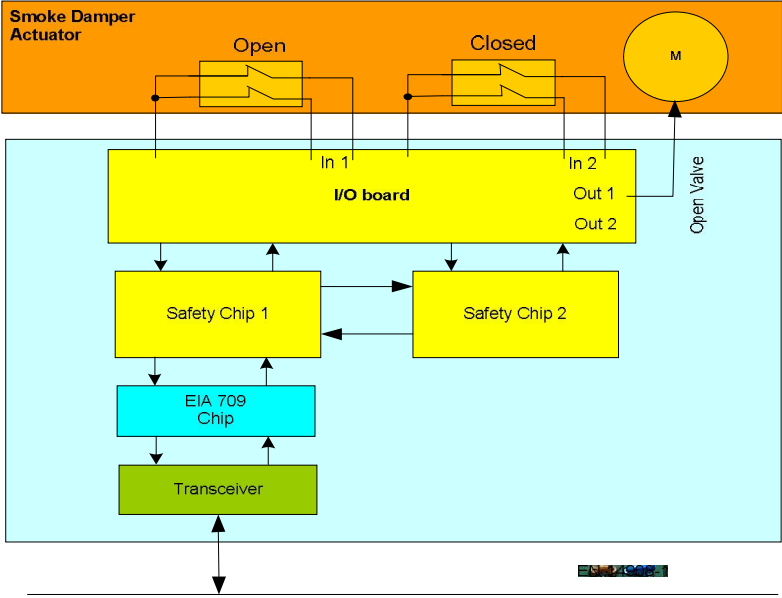
**4.5.3.1. Description of developed hardware**

In work package III, three nodes have been used, two of them with safe hardware extensions to interface to field devices.

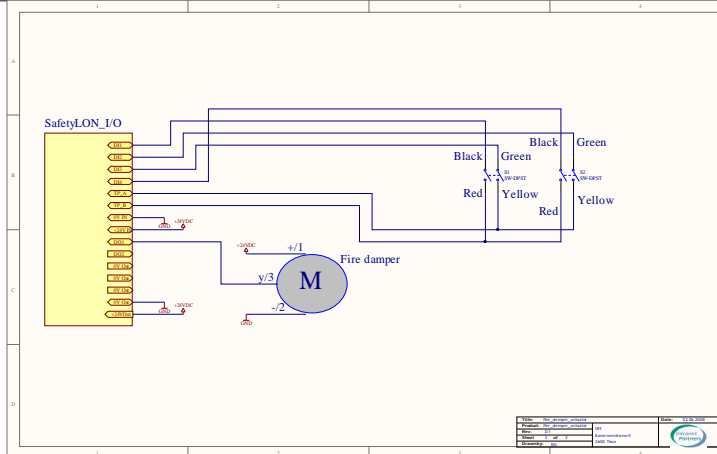
One of the field application nodes controls a *safe fire smoke damper actuator*. The device supports to command and control a safe opened or a save closed position.

In addition, many devices use a spring loaded safe position being activated under heat condition. This mechanical functionality cannot be influenced by electronic controls and its sole purpose is to protect fire from spreading in a zone being already set afire.

Depending on the escape path status of the current segment, the safe position (open or closed to protect fire from spreading towards different segments) is set by Output 1.



**Figure 4.5 - 7 SAFETYLON node and Smoke Damper Actuator**



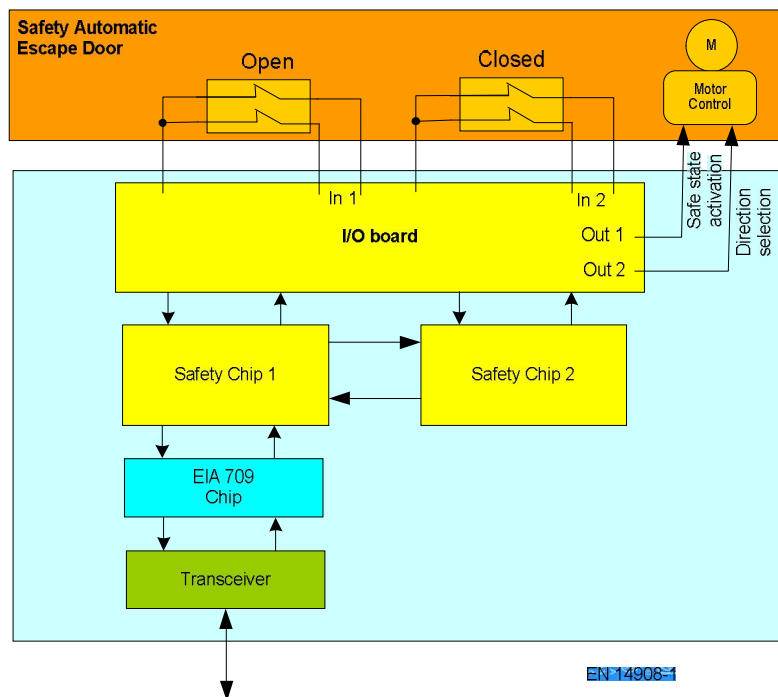
**Figure 4.5 - 8 IO schematics of a safe Fire Damper Actuator**

The available test device only supports two positions, either fully open or fully closed. Drive speed and positions can be configured; however, the absence of safe configuration data does not allow implementing this functionality.

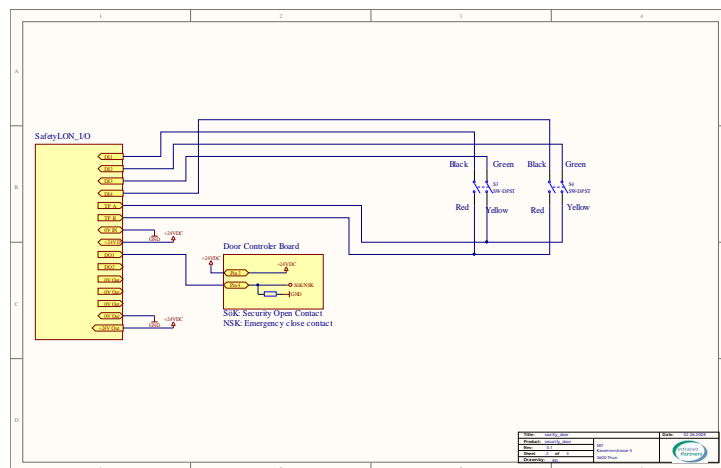
A second field application node controls a *safe automatic door*. The device supports to command and control a safe opened or a save closed position of the automatic door.

For the door control hardware, the safety functionality is working in parallel to the standard hardware overriding the standard LON Interface.

Depending on the escape path status of the current segment, the safe position (open or closed to protect from spreading the fire towards different segments) is set by Output 1.



**Figure 4.5 - 9 SAFETYLON node operating on Automatic Escape door**



**Figure 4.5 – 10 IO schematics of a safe Emergency Door Controller**

The available test device only supports one safe configurable position, either Security Opening or Emergency Closing. The above schematic was applied within the test installation. To test both functionalities, the safe status must be set manually

The safe escape path manager functionality was built on top of a standard Neuron module.

#### 4.5.3.2 Description of developed software

For the demonstrator applications, IBT developed 3 software packages during period III.

(1) The safe automatic door application monitors two two-channel position switches. It periodically samples the two safe inputs “Channel 1” and “Channel 2” and evaluates the state of switches to be copied to the *ivos\_EntryStatus*. Each safe channel contains a dual binary input circuit.

The two binary inputs of each channel are interdependent. The state of the position detection switches is assumed to be “not engaged” only if closed contacts are detected on both binary inputs. If on either binary input an open contact is detected, for safety reasons the state of the position switch is assumed to be “error”. The output *ivos\_Error* will then go to on (100%/1) state.

(2) The damper actuator application monitors two two-channel position switches. It periodically samples the two safe inputs “Channel 1” and “Channel 2” and evaluates the state of switches to be copied to the *ivos\_EntryStatus*. Each safe channel contains a dual binary input circuit.

The two binary inputs of each channel are interdependent. The state of the position detection switches is assumed to be “not engaged” only if closed contacts are detected on both binary inputs. If on either binary input an open contact is detected, for safety reasons the state of the position switch is assumed to be “error”. The output *ivos\_Error* will then go to on (100%/1) state.

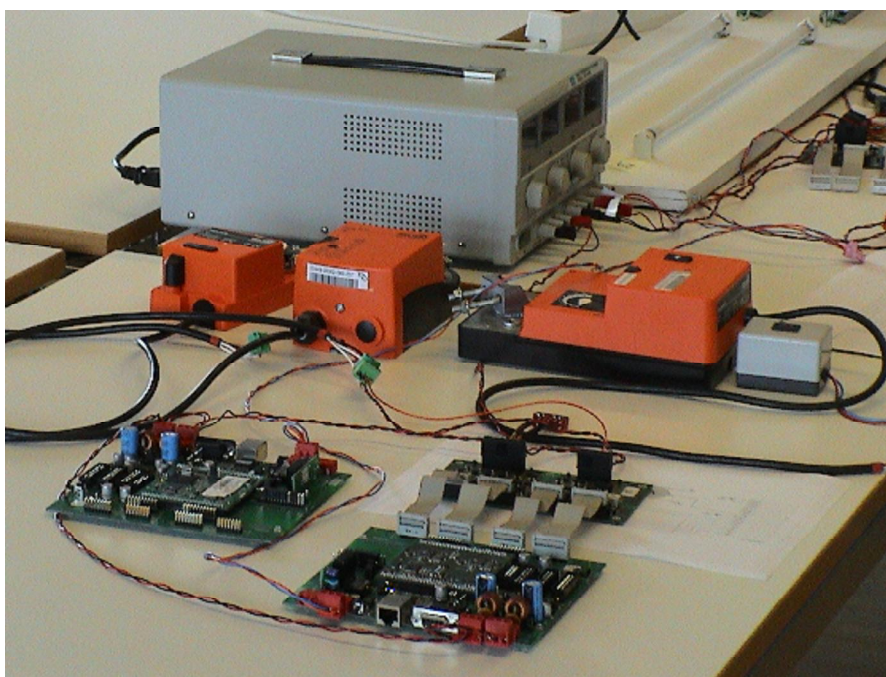
(3) The Escape Path Manager application monitors two two-channel user input switches. It periodically samples the two safe inputs “Channel 1” and “Channel 2” and evaluates the state

of switches. Further, safe network input and output variables are calculating the safe state of the escape path for Damper Actuators, Smoke Detectors, and Automatic Doors and Emergency Lighting.

The two binary inputs of each channel are interdependent. The state of the user input switches is assumed to be “engaged” only if closed contacts are detected on both binary inputs. If on either binary input an open contact is detected, for safety reasons the state of the position switch is assumed to be “error”. The output *nvos\_Error* will then go to on (100%/1) state.



**Picture 4.5 - 11: Full test system using original equipment**



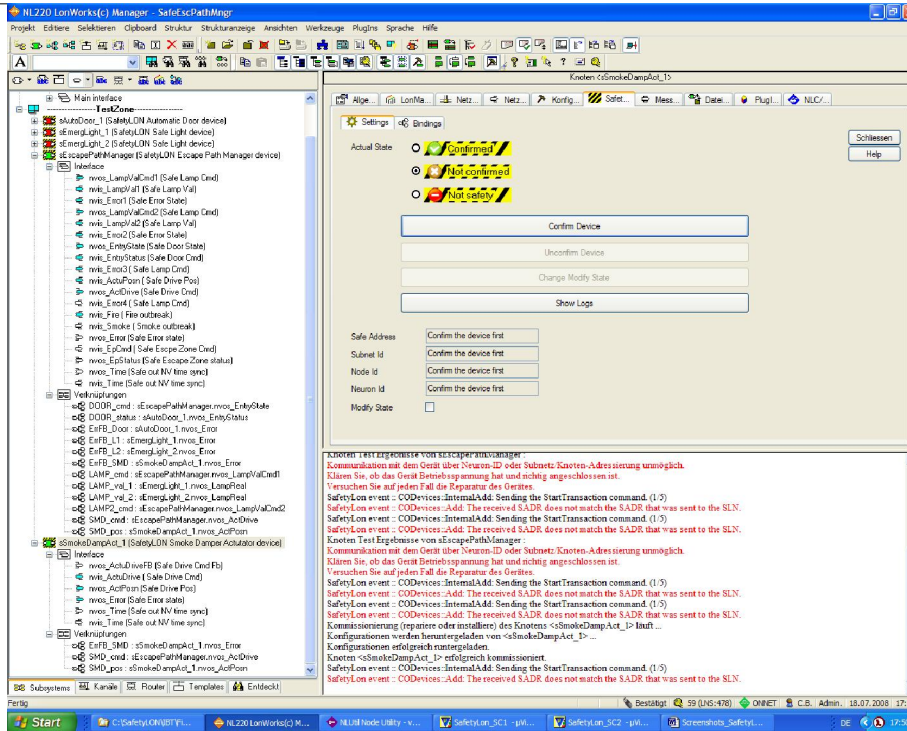
**Picture 4.5 - 12: Smoke Damper Actuators for testing purpose**

**4.5.3.3 Functional test of developed software**

The escape path manager application has been tested with the devices from Record, Belimo and the emergency light application driven from WP 5.1. The picture below shows the complete test system used to test the first drafted version of this demonstrator application using real end devices controlled by the SAFETYLON prototype boards:



**Picture 4.5 - 13: Details with automatic door drive and SAFETYLON Interface**



Picture 4.5 - 14 Safety configuration dialogue in test database

For a detailed report on testing check the file *EscapePathManager\_V1\_0\_Release\_Notes.pdf* in the documentaion section.

### 4.5.3.4 Generated Documentation

The following documentations was generated:

| Document                       | File  |
|--------------------------------|---|
| General description            | SAFETYLON_SME_EscapePathManager_08_1_31_CB.pdf (D17/19)   |
| Release Notes                  | EscapePathManager_V1_0_Release_Notes.pdf (this) (D17/19)<br>ICT_Software_Prototype_071031_Bugs_and_Facts_v1.0_TN.doc  |
| Source Code Documentation      | SME_APP_IBT_FD_AutomDoor_2008_05_10_V1.0_CB.pdf (D19)<br>SME_APP_IBT_FD_manager_devices_2008_06_30_V1.0_CB.pdf (D19)<br>SME_APP_IBT_FD_SmokeDampAct_2008_05_10_V1.0_CB.pdf (D19)<br>SME_APP_IBT_FD_EmergLi_2008_05_10_V1.0_CB.pdf (D19)<br>ICT_Software_Prototype_070917_Description_v1.0_TN.doc (D17/19) |
| Workbench with Source Code     | AutomDoor_V_1_0.zip (D19)<br>SmokeDampAct_V_1_0.zip (D19)<br>EscPathMan_V_1_0.zip (D19)<br>EmergencyLight_V_1_0.zip (D17)   |
| Software Prototype Description | AutomDoorDoxy_V1.0.zip (D19)<br>SmokeDampActDoxy_V_1_0.zip (D19)<br>EscPathManDoxy_V_1_0.zip (D19)<br>EmergencyLight_Doxy_V_1_0.zip (D17)   |
| NL-220 Safety Database         | SafeEscPathMgr_2008_LastDB_Backup.(nl)zip (D17/19)<br>SafeEscPathMgr_Directory.zip (D17/19)   |
| NL-Util Database               | SafeEscPathMgr.nls (D17/19)   |
| Format Files                   | SAFETYLON_iop_profiles.zip (D17/19)<br>SAFETYLON.zip (D17/19)   |

Table 4.5 - 15 Documentation for Escape Path Manager prototype

#### **4.5.4 WP 5.4 Fire detection and intrusion protection (ZDANIA Sp.z.o.o., Poland)**

##### **4.5.4.1. Objectives**

ZDANIA will develop demonstration models for safety applications in the fields of building automation, with special focus on fire & intrusion detection and alarming systems. ZDANIA focuses on three devices dedicated to fire and/or intrusion detection systems: smoke detector, fire alarm manual point, fire alarm enunciator.

##### **4.5.4.2. Description of Work**

ZDANIA implements SAFETYLON modules and SAFETYLON requirements into respective applications, concerning fire and intrusion detection alarm systems. ZDANIA will develop devices for these systems (smoke detector, fire alarm manual point, fire alarm enunciator), which fulfill SAFETYLON requirements on one hand and specific system regulations and requirements on other hand. A working model of an integrated fire alarm system (consisting of smoke detector, fire alarm manual point and fire alarm enunciator) with application of SAFETYLON WP2 - WP4 results will be built, tested and demonstrated.

##### **4.5.4.3. Details**

During period II the main activities of ZDANIA were focused on education in the field of application of IEC 61508 standard and on learning about elaborated results of WP2-WP4. ZDANIA staff participated in three SME workshops increasing its knowledge about safety in control systems and developed SAFETYLON hardware and software.

Also as part of the responsibility of ZDANIA concerning WP5.4, appropriate local standards in the field of fire and intrusion alarm systems were studied and the consequences to WP5.4 were investigated and included in our plans (mainly to the IEC61508 standard).

Also as part of the responsibility of ZDANIA concerning WP5.4, appropriate local standards in the field of fire and intrusion alarm systems were studied and the consequences to WP5.4 were investigated and included in our plans (mainly to the IEC61508 standard).

During period III within the WP5.4. ZDANIA developed a prototype applications (hardware & software) of ZDANIA specific SAFETYLON devices: Pull Station Fire Initiator, Smoke Fire Initiator and were executed and registered as Audible Fire Indicator.

##### ***4.5.4.3.1. Developed prototype hardware***

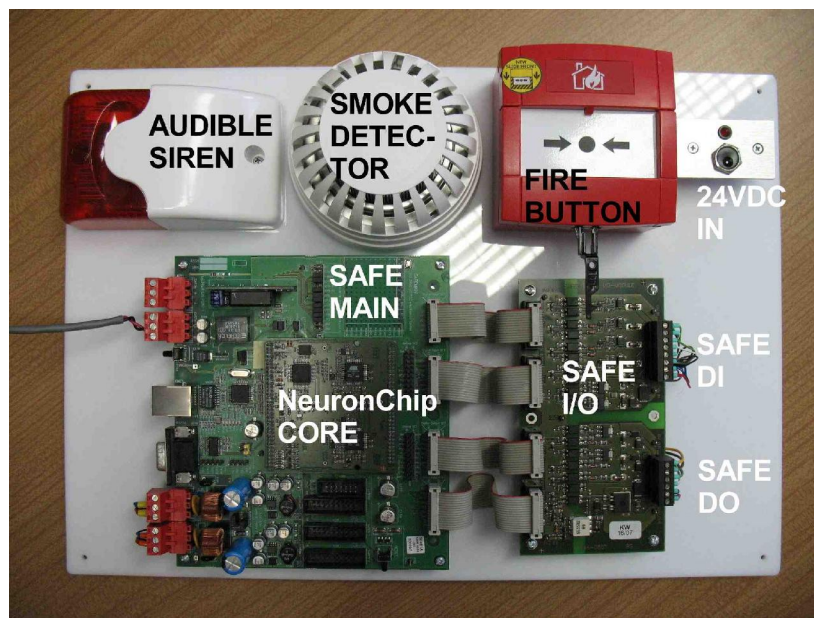
Prototype ZDANIA specific SAFETYLON hardware is shown in the Fig. 4.5 -16.

Prototype hardware includes the SAFETYLON development main board (SAFEMAIN) with the SAFETYLON NeuronChip Core Module and SAFETYLON I/O board with Fire Initiator

switch, Smoke Detector and Audible Siren. All devices are mounted on a single board and connected to each other.

The SAFETYLON MainBoard consists of a dual power supply, network interfaces (FTT-10A/RS485, 10/100BaseT and FX-X1), JTAG1,2,3 connectors, I/O connectors and the Prototype Area.

The SAFETYLON Neuron CoreModule includes two safety chips (ARM AT91SAM7S256) and a chip (NeuronChip Smart FT3120) to access the LON, safety related inputs and outputs as well as a fail-safe unit. Safety Chip No 1 is connected to the Neuron Chip that enables communication over the LON network (EN 14908).



**Picture 4.5 -16: Prototype of ZDANIA specific SAFETYLON applications hardware**

SAFETYLON I/O board includes 4 safe input channels with 2-phase test pulse generator and 2 safe output channels with failsafe unit. All channels are galvanically separated from SAFETYLON mainboard connectors.

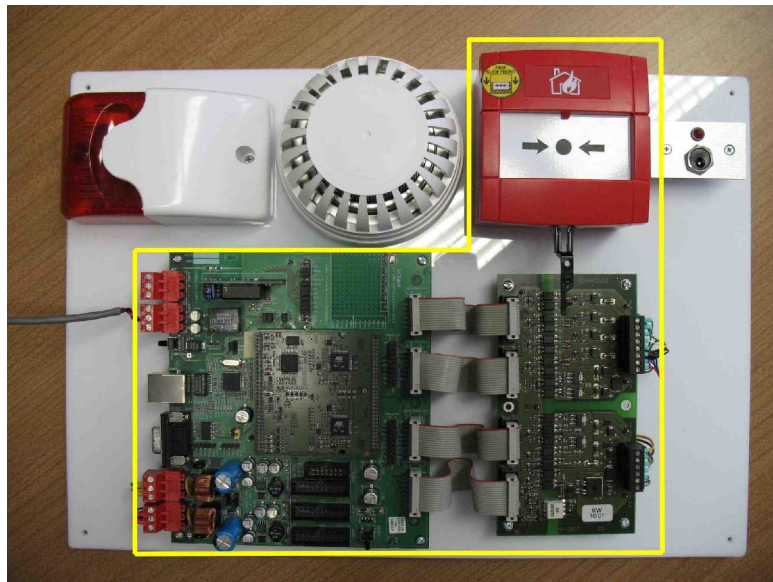
The picture (Fig. 3.2.1) shows the hardware setup: SAFETYLON main board with Neuron Core Module and a SAFETYLON I/O board with attached fire button, smoke detector and audible siren.

#### ***4.5.4.3.2 Pull Station Fire Initiator Application***

The SAFETYLON Pull Station Fire Initiator is the SAFETYLON device that generates SAFETYLON alarm message about fire through the LONWORKS network after its push button is activated. There are also several diagnostic and malfunction messages that are also generated in case of lack communication and/or malfunction.

Prototype SAFETYLON Pull Station Fire Initiator hardware is shown in Fig. 4.5 -17  
Realized by the device software algorithm:.

- System initials all variables and sets them to default values.
- System receives input network variable and depending on its value either goes to “test mode” or not.
- System checks Pull Station Fire Initiator’s inputs.
- If system detects the state of both contacts of the Pull Station Fire Initiator as open it initiates alarm.
- If system detects the state of both contacts of the Pull Station Fire Initiator as closed then checks the state of the tamper switch.
- If system detects the state of the tamper switch as closed then system checks initiator’s inputs again.



**Picture 4.5 - 17: Prototype SAFETYLON Pull Station Fire Initiator hardware**

- If state of tamper switch is open then system sends information about state of initiator.
- If system detects the state of only one contact of the Pull Station Fire Initiator as closed then system starts counting the discrepancy time and checks initiator’s inputs. While discrepancy time is being counted application stays in safe state. The application may only switch back to the normal state when it detects closed contacts on both digital inputs.
- When the discrepancy time counting is finished and switch is still open then system initiates alarm.

#### ***4.5.4.3.3 Smoke Fire Initiator Application***

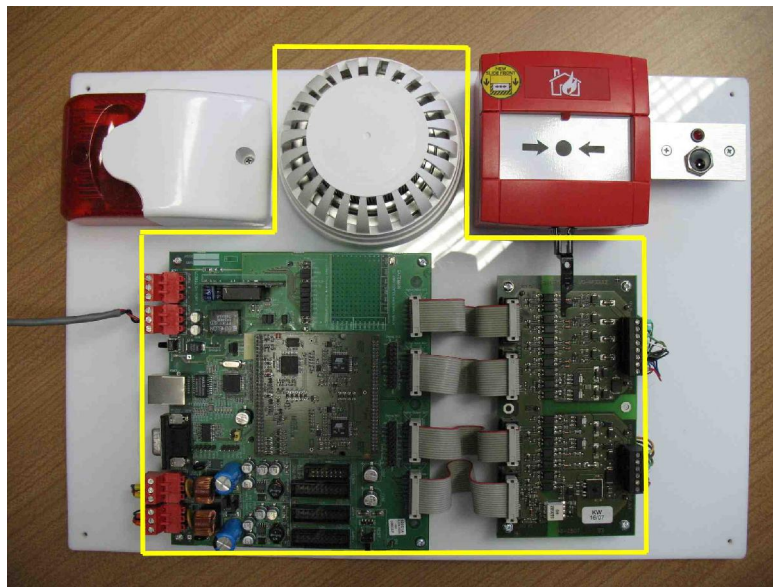
SAFETYLON Smoke Fire Initiator is the SAFETYLON device that generates the SAFETYLON alarm message about fire through the LONWORKS network after its detector detects smoke. There are also several diagnostic and malfunction messages that are also generated in case of lack communication and/or malfunction.

Prototype SAFETYLON Smoke Fire Initiator hardware is shown in Fig. 4.5. – 18.

---

Realized by the device software algorithm:

- System initials all variables and sets them to default values.
- System receives input network variable and depending on it's value either goes to "test mode" or not.
- System checks Smoke Fire Initiator's inputs.
- If system detects the state of both contacts of the Smoke Fire Initiator as open it initiates alarm.
- If system detects the state of both contacts of the Smoke Fire Initiator as closed then checks the state of the tamper switch.
- If system detects the state of the tamper switch as closed then system checks initiator's inputs again.



**Picture 4.5-18: Prototype SAFETYLON Smoke Fire Initiator hardware**

- If state of tamper switch is open then system sends information about state of initiator.
- If system detects the state of only one contact of the Smoke Fire Initiator as closed then system starts counting the discrepancy time and checks initiator's inputs. While discrepancy time is being counted application stays in safe state. The application may only switch back to the normal state when it detects closed contacts on both digital inputs.
- When the discrepancy time counting is completed and the switch is still open then system initiates alarm.

#### ***4.5.4.3.4 Application Audible Fire Indicator***

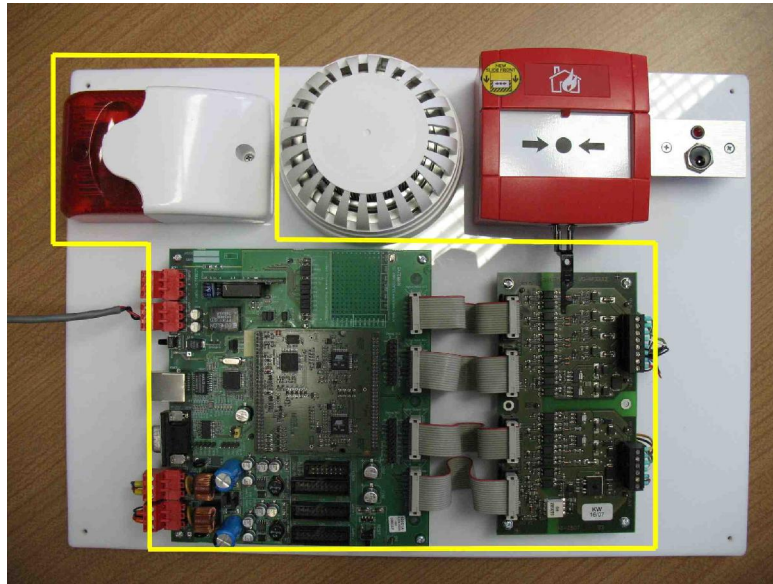
SAFETYLON Audible Fire Indicator is the device that activate fire alarm siren after it receives fire alarm SAFETYLON message from fire initiator device through the LONWORKS network. Alarm is also generated if there is no SAFETYLON message (heartbeat) for the specific period of time. There are also several diagnostic and malfunction messages that are also generated in case of lack communication and/or malfunction.

---

Prototypic SAFETYLON Smoke Fire Initiator hardware is shown in Fig 4.5 -19

Realized by the prototype device software algorithm:

- The System initiating all variables and settings them in default positions.
- The System checks safe input network variable.
- If the system detects the state of safe network input variable as alarm then audible siren is activated.
- If the system detects the state of safe network input variable as no alarm then it leaves audible siren off and checks the state of the tamper switch.



**Picture 4.5 - 19 Prototype SAFETYLON Audible Fire Indicator hardware**

- If the system detects the state of the tamper switch as closed then system checks initiator's inputs again.
- If the state of tamper switch is open then system sends information about state of initiator.
- If the system doesn't receive safe network input variable for 400 milliseconds or more it activates audible siren.

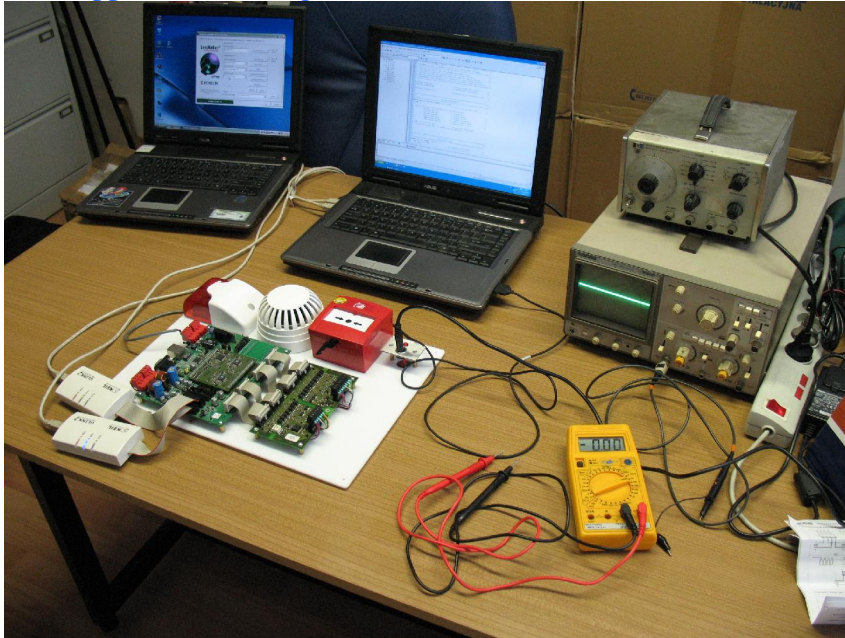
#### ***4.5.4.3.5 Application Tests***

Functional testing was performed. The behaviour of the ARM processors (Safety Chips 1&2), digital safe I/O's and the network variables and the behaviour of the whole node were observed. There was one device tested at any one time.

The SAFETYLON ARM chips were started by use of the Keil start up environment. SAFETYLON program applications were compiled and downloaded through Keil J-tag interfaces. The Echelon Short Stack was uploaded once to the NeuronChip working as an LONWORKS network interface (FTT-10).

The node was first commissioned in the traditional way with LonMaker and afterwards the SAFETYLON Layer Library (SLL) and the SAFETYLON Tool were used.

The Application testing environment is shown below:



**Picture 4.5 - 20: ZDANIA Application testing environment**

#### **4.5.4.3.6 Product Perspective**

There are no fire alarm digital systems using the LONWORKS digital transmission network developed under the rules of SIL classification (IEC 61508). Developed by ZDANIA three devices that are elements of the Fire Alarm System demonstrate that it is possible and purposeful to develop Fire Alarm Systems based on the SAFETYLON Technology that can fulfill a high level of security requirements for such systems.

#### **4.5.4.3.7 Generated documentation**

| <b>Document</b>                | <b>Description</b>  | <b>File</b>  |
|--------------------------------|---|--|
| Release notes                  | Description of applications development   | SAFETYLON_ZDANIA_ReleaseNotes_.pdf<br>ICT_Software_prototype_071031_Bugs_and_Facts_v1.0_TN.doc |
| Applications documentation     | Software Requirement Specification and Design Description for Pull Station Fire Initiator           | SME_APP_ZDANIA_PullStationFireInitiator.pdf  |
|                                | Software Requirement Specification and Design Description for Smoke Fire Initiator                  | SME_APP_ZDANIA_SmokeFireInitiator.pdf  |
|                                | Software Requirement Specification and Design Description for Audible Fire Indicator                | SME_APP_ZDANIA_AudibleFireIndicator.pdf  |
| Software Prototype Description | System Files Prototype description  | ICT_Software_Prototype_070917_Destruction_v1.0_TN.doc  |
| Source Code Documentation      | This files contains sources files documentation generated with use of Doxygen program.              | SAFETYLON-PSFI_Doxy_V1_0.chm<br>SAFETYLON-SFI_Doxy_V1_0.chm<br>SAFETYLON-AFI_Doxy_V1_0.chm     |
| Workbench with Source Code     | This files contains complete catalogues with all data needed for proper compilation of source code. | SAFETYLON-PSFI.rar<br>SAFETYLON-SFI.rar<br>SAFETYLON-AFI.rar                                   |

**Table 4.5 -21: ZDANIA Application testing environment**

All documentation files are stored on the internal SAFETYLON server in the specifications directory.

#### **4.5.5. WP 5.5 Emergency Exit Button (Nodex AB, Sweden)**

##### **Note of Anders Blom of NODEX:**

After participating in the project for several months we learned that there is no way to test a dual occupancy detector for safety. We therefore decided to develop, build and market a small, self-contained safe system solution (push button – door lock) which can also be integrated into larger SAFETYLON systems. The solution can be sold stand-alone solving the safety problems of emergency exit doors which should be locked to prevent intrusion but must be unlockable due to fire regulations. This substitution was proposed to and accepted by the PMC.

##### **Objectives**

The initial plan was to design a safe occupancy detector but later the decision was taken to focus on locks. The idea is to solve the problem of unauthorized access through escape doors which is common when lock levers are hidden in the lock, maybe behind a plastic cover. Also it poses a big threshold if you have to “break the glass” of an emergency exit button. Also there will be no lock lever to make life easier for intruders in the night.

##### **Description of Work**

The development of the dual detector with SAFETYLON technology will occur in several steps:

- specify the general requirements
- integrate the SAFETYLON Neuron-based control module
- implement a prototype of the device and performance of lab tests
- build a simple system
- write all documentation.
- perform the final CE-tests

##### **Details PII**

Period II has been focused on studies of the IEC61508 standard and which implications it will have regarding our Lock and Exit Button. We have attended several meetings to learn in more detail about the safety standard and also about the latest steps performed by the RTD's. We have studied and have got familiar with the Keil Development System.

##### **Details for PIII**

Period III has been focused on the design of hardware and software which is not depending on the SOS. Since the SOS has not been fully implemented in time Nodex has switched focus from a real running preproduction HW/SW to complete the other areas for a complete product (except marketing). A new mechanical housing was designed to support safe/non-safe installation in a combined installation. This allows non-safe systems like HVAC/Lighting/Security to be combined in the same housing but still be able to hold all regional regulation approvals which is current today.

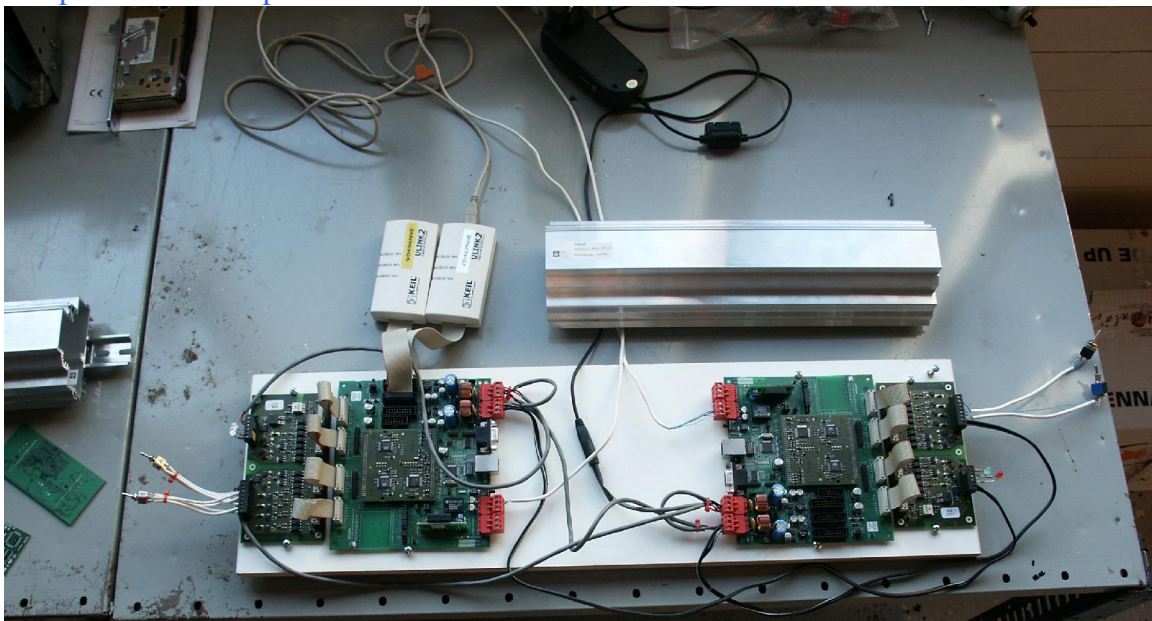
To design a "perfect" product you need to think outside the box and look into different areas where software and electronics are not the only issue. When projecting a safe lock/button you need to cover installations, configuration, future maintenance and of course the users behaviour. For the installation you need to have a good simple mechanical product which makes it possible to integrate different functions in one single node. This means that HVAC/Lighting/Security should/can be housed in the same mechanical housing. Nodex has

developed a solution for this within the scope of SAFETYLON. This means that Nodex already has a winner solution regarding a new product which will be used in a broader range. There is also a company ready to switch over and use the Nodex technology for all their future products.

More in dept information can be retrieved from the document “Lock\_and\_Exitbutton\_Device.doc” from the Nodex part of Projectplace.

Functional testing of software has not been performed due to the fact that the engineer in charge left Nodex in April 2008 and at this time there was no stable environment and test bed for him to qualify against.

In the future we will proceed with the project as soon as we have a working SOS. This will be done with a final customer (manufacturer of safety products) due to the very high cost to complete a finished product.



**Picture 4.5 – 22 Lock/Button prototype application with its future mechanical housing**

#### **4.5.6. WP 5.6 Access control (Apice s.r.l, Italy)**

##### **Objectives**

APICE will implement a safe control node for access control along the lines of its existing field proven product line. The advantages in hazardous situations will be:

- to guarantee open exit in case of fire or other catastrophes
- to block access to non- authorized people
- in case of an emergency, to make available a list of people inside the building or within a protected area, to make the check at meeting point.
- to prevent the opening of special fire doors to people who are not firemen.

##### **Description of Work**

The development of the SAFETYLON Access control demonstrator follows several steps:

- write the requirements specification
- design in of the safety control module of WP4

- 
- build a prototype and perform lab tests
  - integrate the prototype node in a small safe access control system
  - limited documentation
  - ct presentation

## Details Period II

The period II was used for education of new Project Engineer related to the SAFETYLON Project and documentation. After, the SAFETYLON seminar was hold in Vienna, we have focused our attention on:

1. Keil Development System
2. Keil Hardware Programmer (ULINK-2)
3. Test on prototype Hardware (I/O Board, Main Board and Core Module)
4. Test on Safe Operating System
5. Definition of Safe Control Node schematics

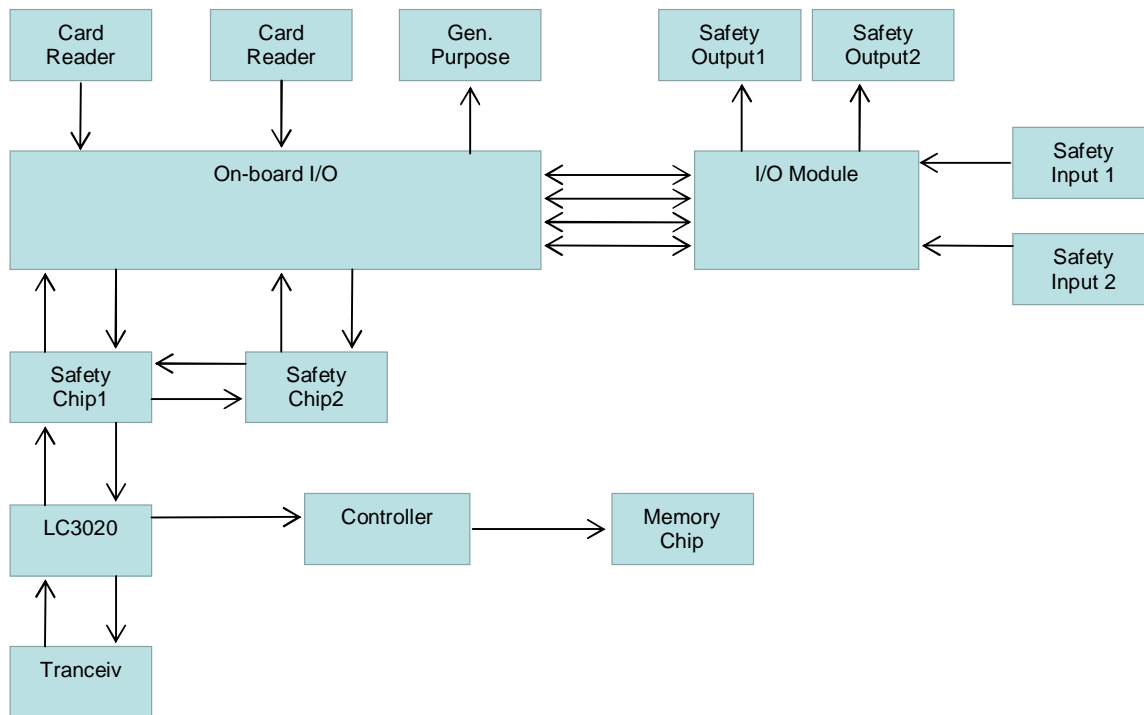
At the moment, we are waiting for the first Safe Control Node prototype. When we will have the prototype we will start with the tests.

## Details of Period III

### 4.5.6.1. The Control Access Node (CAN)

In Period III APICE has focused on the revision of the hardware as well as the design and development of the application software for access control (primarily on microcontroller level, no extensive use of SOS interface). We have tested the software with a RS232 communication and we have implemented the code including the interface of the module to the card reader. Furthermore, we have implemented the communication with an LC3020 microcontroller (SPI communication). We have tested the reader communication with a reader at 125kHz technology and a reader i.Class at 13.56 MHz.

The Apice Control Access Node (CAN) is designed to control one or two protected gates in the Access Control System (see the schematic block diagram in Figure 4.5 – 22 below).



**Figure 4.5 - 23: Access Control schematic block diagram**

The CAN can manage two different card readers: magnetic or proximity, that can be used to implement an access procedure based on user's identification. Two different applications allow to manage from the reader ISO clock+data or Wiegand data output.

The CAN includes 3 (three) On/Off Inputs:

- to sense the door status (open or closed) (Safety Input)
- to acquire commands from a pushbutton to unlock the gate. (Safety Input)
- one input is exclusive to tamper protection. (NO Safety Input)

It also includes also 2 (two) relay outputs that can be used to drive:

- electric locks (Safety Output)
- local alarm device (Safety Output)

Besides, it includes 4 (four) outputs to drive LEDs and/or buzzers embedded in the card readers, which are automatically driven by the node, to signal a granted or not granted access and the door/gate status.

The CAN communicates to the LONWORKS network through the Loytec transceiver.

The CAN has got an on-board memory to store a local list up to 100 enabled card codes. This list allows to build a simple access control without using any other devices like database controllers. The local list can be also used in case of failure of the database manager.

## **4.5.6.2 Description of developed hardware**

### ***4.5.6.2.1 IN1/IN2 Safety Inputs***

IN1 and IN2 safety inputs are suitable to interface clear contact switches. Each input can be used to interface:

- Door or gate state switch (normally closed, when the door is closed).
- Pushbutton to open the door or the gate manually.
- Others clear contact switches for any general purpose.

### ***4.5.6.2.2 Tamper Input***

The TAMPER input is suitable to interface a normally closed clear contact switch. Tamper controls:

- the box cover closing, using the particular spring switch.
- the reader 1 wiring.
- the reader 2 wiring.
- the external tamper input.

When one of these conditions fails, a tamper alarm is generated.

### ***4.5.6.2.3 Relay Safety Outputs***

The CAN includes two safety relay outputs to unlock an electronic door.

### ***4.5.6.2.4 Reader Interface (ISO TTL Data+Clock)***

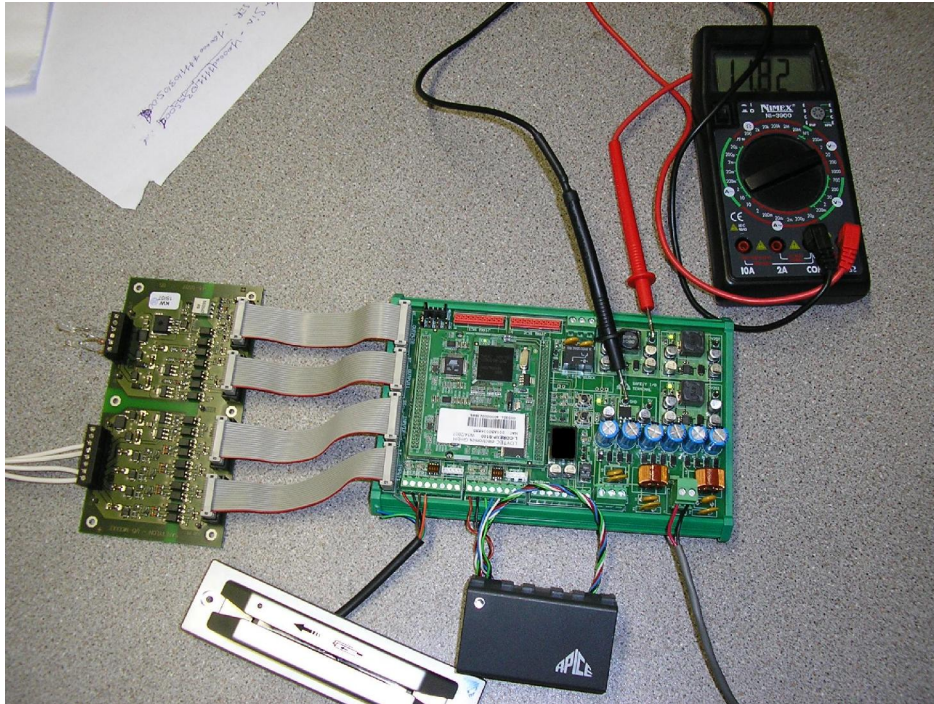
This interface is the most used with magnetic card reader. It consists of two signal lines, the clock and the data. During the clock falling edge, the data is valid. To be managed by CAN, the clock signal must become active at least 3ms before starting valid data. This is not a problem for standard magnetic card reader, because magnetic card encoding complies with this requirement. Be careful, when interfacing a device with ISO data+clock output emulation.

### ***4.5.6.2.5 Wiegand Interface***

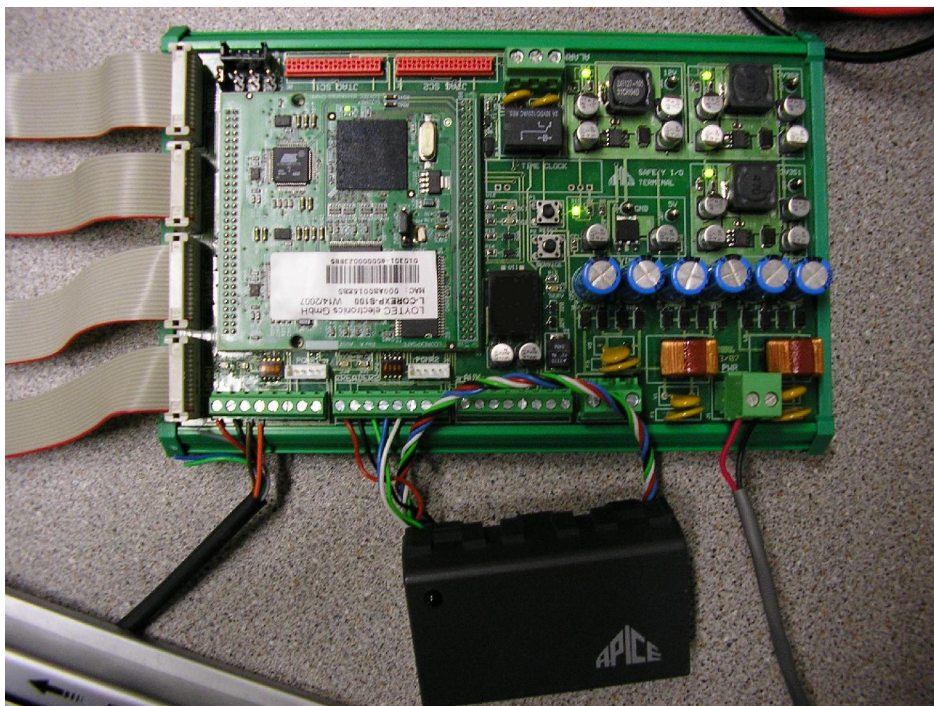
This interface consists of two signal, the logic level 0 and the logic level 1. Usually both lines are on logic level 1. When one line goes to level "0" and returns to level "1" the related logic level is transmitted. Only one line at time can transmit a data pulse. In order to interface a device with the CAN, the distance between the data pulses must be 4ms or higher.

#### ***4.5.6.2.6 Service Pin and Service LED***

The CAN is provided with service pin pushbutton and service LED. The pushbutton is used, to send the unique Neuron ID to an installation or diagnostic tool the unique node Neuron-Id. The service LED is useful to discovery the node state.



**Picture 4.5 – 24 Control Access Node with two reader types: magnetic and proximity**



**Picture 4.5 – 25 Control Access Node with proximity reader**

### **4.5.6.3 Description of developed software**

For the demonstrator applications, Apice developed a software package during period III:

We have developed a software for the access control (only for microcontroller, without SOS). We have tested the software with a RS232 communication and we have implemented the code including the interface of the module to the card reader. Furthermore we have implemented the communication with an LC3020 microcontroller (SPI communication). We have tested the reader communication with a reader at 125KHz technology and an i.Class reader at 13.56 MHz. Now we are working on developing the SAFETYLON application as well as to test the entire device.

### **4.5.7. WP 5.7 Fault Indication and Switch Control Panels (Unitro Fleischmann, Germany)**

#### **Objectives**

As a manufacturer of fault indication, remote control, and monitoring systems using LON technology UNITRO plans to convert part of their existing product line of industrial I/O modules to the new SAFETYLON standard in order to have access to new niche markets in industrial FDC applications.

#### **Description of Work**

A demonstration application is planned in monitoring of smoke damper positions. The use of SAFETYLON will allow the deployment of error detections monitoring systems in safety relevant industries. Here, SAFETYLON would allow for a secure transmission of alarm events to centralised monitoring and control panel. Furthermore, the control of the smoke damping module could be performed in a safety mode once the new technology platform will be available for SMEs.

As a second demonstration application UNITRO plans to develop switch monitoring systems for nuclear power plants. UNITRO already installed simulators of switch monitoring systems based on LON in several nuclear power plants in Germany and abroad. The SAFETYLON technology designed to achieve SIL4 will offer the possibility to integrate safe LON technology not only in simulation mode but also in real world control applications in safety critical power plants and related applications.

#### **Details**

The following activities were performed during period II:

- working with the IEC61508 standard in order to be prepared for the development of the safe module, reviewing the internal handbook of the company (ISO 9000) to see, which parts of the production had to be changed in order to meet the safety-requirements.
- working with the KEIL development kit for the ARM7 Controllers in order to test the functionality of this controller and to see, which applications we can implement in our SAFETYLON- modules to meet the safety requirements.
- participating in the SAFETYLON workshops for SMEs in Vienna to work with a prototype module and the SAFETYLON chip the first time

- Checking the electronic parts used in the prototype (bill of materials) for the possibility to implement them in our own module; and also checking the availability of these parts because of the rapidly changing world of electronics!

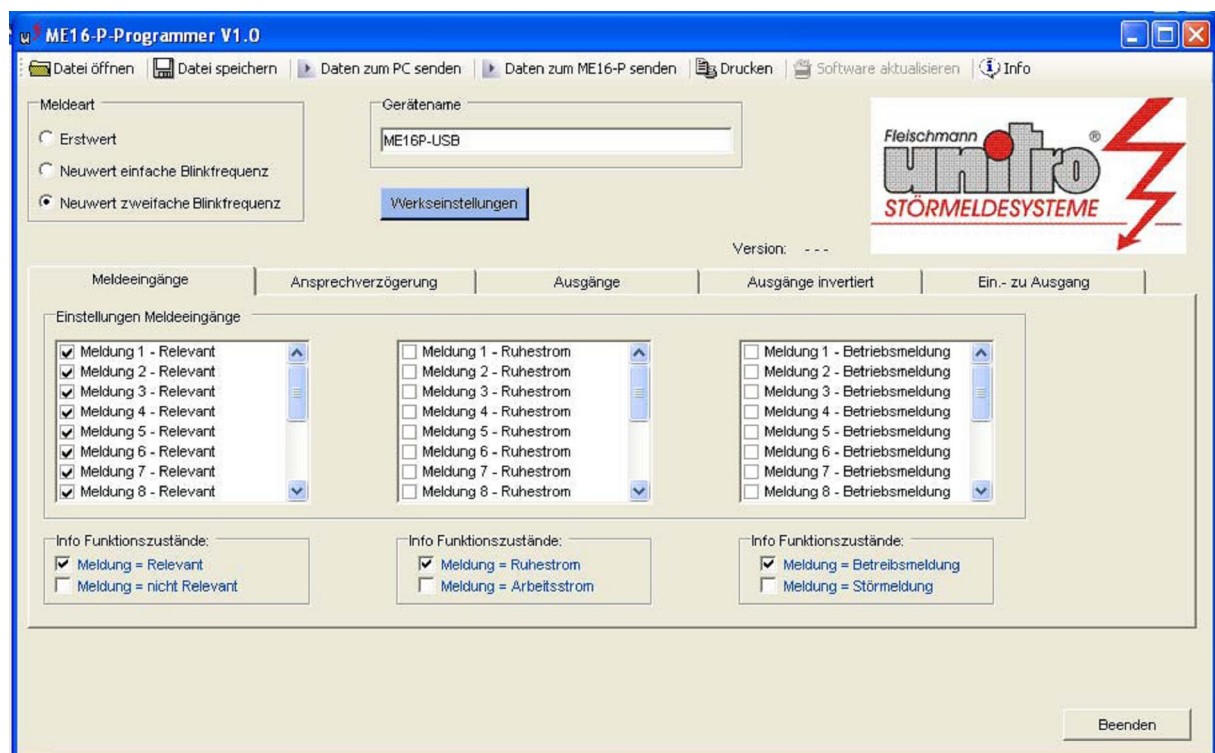
### Details of Period PIII

In Period III we have been working on the design of hardware and software for the fault indication system including the interface to the SAFETYLON “network-card”. The challenge was to have a system working in both situations, safe and non-safe. So it was necessary to have a design, which is flexible in use. This was the reason to design a modular system with different interfaces. When the implementation of the SOS is completed in the sense that it is commercially available, we can finish the SAFETYLON card with little additional effort to make the system safe. This duality of safe and non-safe designs on practically the same hardware is one of the strong points of the SAFETYLON concept.

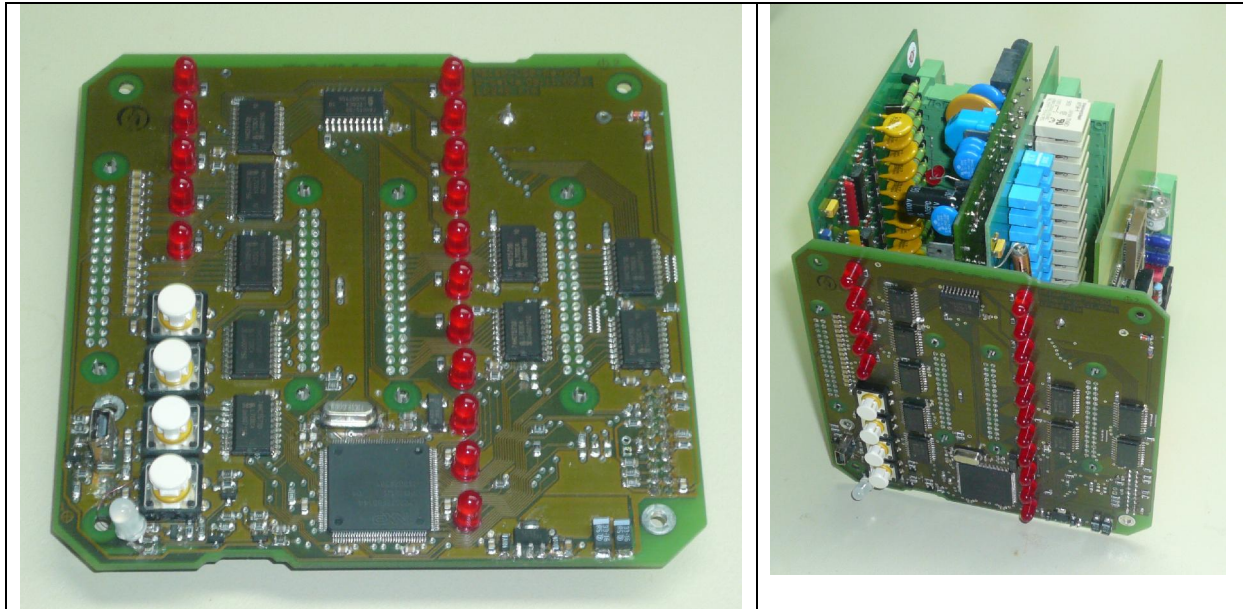
As the system is programmable for the customer, it was necessary to write an easy to use software and a connection for the programmer-software with an up-to-date interface. For this reason, we implemented an USB-Interface.

We also had meetings with our customers to discuss what else could be implemented in soft- and hardware to have a flexible and convertible system. One very important issue, which came out of the discussion with our customers was the capability of a software update in a running system, because in the future, we expect updated software specifications, which we have not implemented in the system at the moment.

So now we have a very flexible module for safe and non-safe applications.



**Picture 4.5 - 26 Screen-print of fault indication software application**



**Picture 4.5 - 27 CPU (left) and with interface cards of fault indication system (right). The current non-safe CPU needs to be replaced by a safe CPU card**

#### **4.5.8. WP 5.8 SAFETYLON Network Management Tool (NEWRON System, France)**

##### **Objectives**

The objective of this development is to integrate into the software integration tools of NEWRON the basic functionality for the safety tools developed by RTD performers. The idea is to develop a graphical and non-technical demonstration application including the entire capabilities of the system. The software developed by RTD performers will be combined with NEWRON's off the shelf network management tool to create a prototype.

##### **Description of Work**

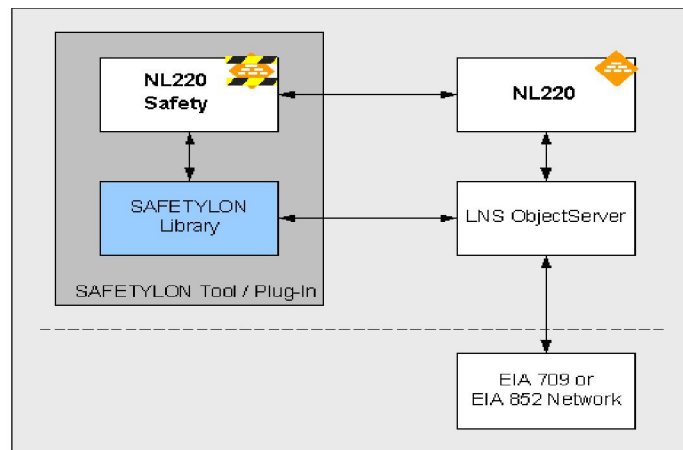
The tool software developed in WP 3 led by FH DO has to be evaluated and integrated into a graphical and intuitive software product derived from the company's existing range of software tools. Therefore, a good understanding of the complete system is required so that the best GUI and HMI functions can be implemented. Additionally, a complete understanding of the lower software layers (developed by the RTD performers in WP 2) to interface with this kernel is of prime importance. NEWRON will be directly interfacing with the RTD performers to understand the software kernel basis but also with the complete team of core SMEs to design a high level and intuitive software tool to manage, maintain and visualize safety products in a safety network.

The demonstration software will be limited to software prototyping only. This means there will be little documentation, no help files, no installation manual, and no multilingual support and only Windows XP will be supported.

##### **Details Period II**

Newron System participated in the SME meeting in Vienna on May 3 and 4, 2007.

Advancement of the Management DLL was not sufficient to be able to start development of the management tool. We are in close contact with FH Dortmund and are standing by for the first DLL release.



**Figure 4.5 – 28 Interaction of the NL220 Safety Plug-In with the Standard Tool NL220**

### Details and results Period III:

#### (1) Requirements of the software

Requirements of the software were:

- **Fully compliant with NL220.** This means that NL220 Safety must include all functionalities of NL220 normal in order to use the functionality of NL220 to manage the LonTalk side of a Safety Lon Network.
- **Generic**  
NL220 Safety must be able to install any Safety Devices not being concerned by the application embedded in the device or by the Safety network variables supported or not.
- **Confirming a device** NL220 must be able to confirm a device. The confirmation must follow the exact specifications of Safety protocol with visual confirmation.
- **Confirming a safe binding** NL220 must be able to build a safe binding between two bound network variables. This includes the confirmation of the producer, the confirmation of the consumer and the assignment of the producer to the consumer. The entire binding procedure must follow the exact specifications of the Safety protocol with visual confirmation.
- **Entering /Leaving Modify State** NL220 must be able to display and change the modify state of a safety device.
- **Safety Log** A special log file must be generated by NL220 for any safety action
- **Unconfirming a safe binding** NL220 must be able to unconfirm a safety binding device. Unconfirmation must follow the exact specifications of the SAFETYLON protocol with visual confirmation.
- **Unconfirming a device** NL220 must be able to unconfirm a device. Unconfirmation must follow the exact specifications of SAFETYLON protocol with visual confirmation.
- **Printing list of safety device** NL220 must be able to print the list of safety devices of a project.

- **User's guide**A user guide must be delivered about how to use NL220 safety with safety devices.

(2) **Development of NL220 Safety**The entry point of the development of NL220 Safety was the Plug-In and the Safety DLL.

An intensive and fruitful technical cooperation was maintained between Newron System and FH Dortmund (Michael Holz , Martin Mentzel)

A first step was a meeting in Toulouse with Eric Ferro of Newron System, Michael Holz and Martin Mentzel to achieve two objectives:

- Train Newron System in the Safety DLL
- Train Newron System in Safety Plug-Ins

Following this in depth introduction the development of NL220 was performed in Visual C++ 5.0 creating an ATL client to the Safety DLL.

The full development of NL220 was embedded in the standard NL220 project making NL220 Safety a new NL220 product including the NL220 standard product plus the NL220 Safety enhancement.

(3) **Complexity of the project** The first challenge was to master the Safety DLL and its COM public interface. The second challenge was to develop NL220 Safety as a part of NL220 Standard without disrupting the actual workflow of standard NL220. Finally the most important challenge was to follow EXACTLY the EN 61508 safety procedures during the development simply because we are dealing with Safety.

#### (4) **Description of developed software**

The developed software is based on the existing NL220.

NL220 safety can be described as the composition of two parts :

- Standard LonTalk configuration, including commissioning and binding.This is supported by the standard functions of NL220. This is out of the scope of this project.
- Safety ConfigurationThis includes
  - Device safety confirmation
  - Change device Modify state
  - Device safety unconfirmation
  - Device safety logs
  - Some printing
  - Network variable producer/consumer safety confirmation
  - Network variable producer/consumer safety de-confirmation
  - Network variable producer heartbeat setting
  - Network variable producer assignment to network variable consumer
  - Network variable producer unassignment from network variable consumer

#### (5) **NL220 safety is protected by special hardware key that includes :**

- NL220 features
- Credits
- NL220 safety feature

Without an appropriate hardware key **NL220** safety cannot be used.

#### (6) **Commissioning a safety device :**

- Fully supported

- 
- The steps are :
    - Commission the device in the LonTalk network (standard commission)
    - Safety commission
    - Full support of visual confirmation for safety security

**(7) Changing Modify state**

- Fully supported
- A safety device can be put or leave in the Modify state at any time
- Full support of visual confirmation for safety security

**(8) Uncommissioning a safety device :**

- Fully supported
- The steps are :
  - Safety uncommission
  - Uncommission the device in the LonTalk network (standard uncommission)
  - Full support of visual confirmation for safety security

**(9) Printing**

- List of safety devices with SADR
- Details of safety devices with SADR

**(10) Network variable producer/consumer safety confirmation**

- Fully supported
- The steps are :
  - Make the standard LonTalk binding with NL220
  - Confirm the network variable in the Safety network Full support of visual confirmation for safety security

**(11) Network variable producer/consumer safety deconfirmation**

Fully supported

- The steps are :
  - Unconfirm the network variable in the Safety network
  - Remove the standard LonTalk binding with NL220
  - Full support of visual confirmation for safety security

**(12) Network variable producer heartbeat setting**

Fully supported

- Set the heartbeat
- Full support of visual confirmation for safety security

**(13) Network variable producer assignment to network variable consumer**

Fully supported

- Select the producer and assign it to the consumer
- Input the expected time
- Full support of visual confirmation for safety security

**(14) Network variable producer unassignment from network variable consumer**

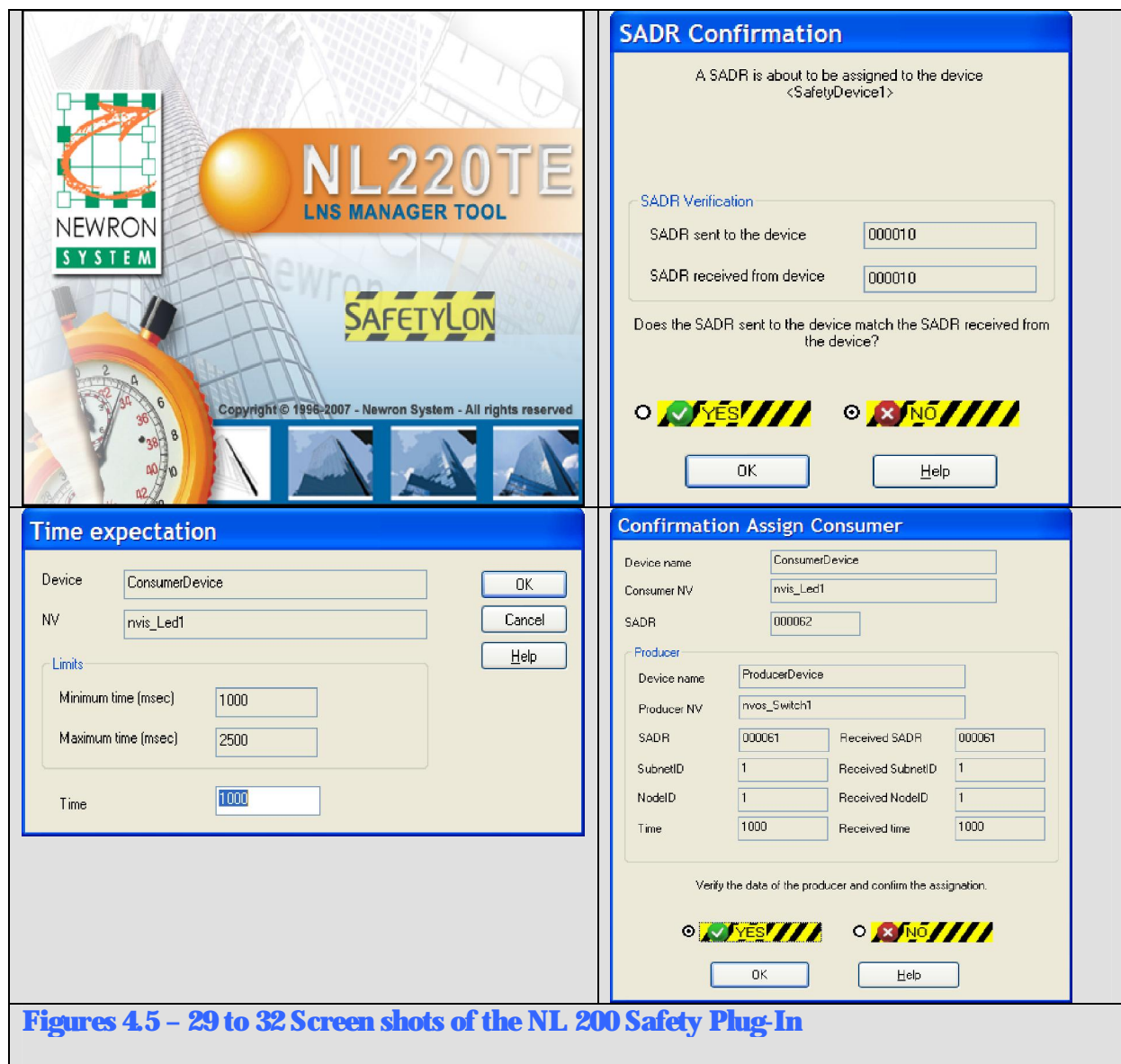
- Fully supported
- Select the producer and un-assign it from the consumer
- Full support of visual confirmation for safety security

**(15) Device safety logs**

- Fully supported
- An individual log file is saved by NL220 safety for any Safety operation
- The individual log file can be displayed at any time in NL220 safety

**(16) Full compliance with the SLL Plug-In**

- NL220 safety is fully based on the SLL API developed in WP3
- NL220 safety is fully compliant to SLL Plug-In.
- This means :
  - any changed in the Plug-In are taken in account in NL220 safety
  - any change done in NL220 safety are taken in account in the Plug-In

**Figures 4.5 – 29 to 32 Screen shots of the NL 200 Safety Plug-In****(17) Functional test of developed software**

NL220 safety has been tested with two safety prototype devices.

---

Test has been performed for:

- Device safety confirmation
- Change device Modify state
- Device safety unconfirmation
- Device safety logs
- Printing
- Network variable producer/consumer safety confirmation
- Network variable producer/consumer safety deconfirmation
- Network variable producer heartbeat setting
- Network variable producer assignment to network variable consumer
- Network variable producer unassignment from network variable consumer
- Full installation on empty Windows OS

### (18) **Plans for enhancement of developed software**

Enhancement that could be done in collaboration with other Safety companies is:

- Safety Parameters
- Safety Status
- Safety Password Checking and Setting
- Full network commissioning

### (19) **Generated Documentation**

Documentations are:

- **Commissioning and Binding safety devices with NL220.doc**
- A full white paper describing how to use NL220 Safety to commission and to bind SAFETYLON devices.
- **NL220 Safety Tests Results.doc**
- Test results of NL220 safety
- **NL220\_safety.chm**  
The context help file of NL220 safety (included in the full installation tool)
- **NL220\_safety\_4\_5\_0\_5.exe**  
Full installation of NL220 safety.
- Includes the installation of :
  - NL220 safety and its dependencies
  - LNS server and its dependencies
  - SLL library and its dependencies

### (20) **Other**

Documentations are:

What was not done:

- Safety Parameters
- Not implemented in SLL library
- Password Checking and Setting
- Not implemented in SLL library
- Advanced Safety Status
- Not implemented in SLL library
- Complete network testing
- Tests done only with two devices

---

**(21) Sources deliverables**

It was not possible to deliver the whole source project of NL220 Safety because NL220 safety development was done as a part of NL220 standard.

Software explicitly developed for NL220 safety was made available in source code in Deliverable D24.

This includes:

- AppDeviceSafety.cpp, AppDeviceSafety.h,
- DialogHeartbeat.cpp, DialogHeartbeat.h
- SafetRejectHeartbeatDlg.cpp, SafetRejectHeartbeatDlg.h
- SafetyAssignConsumerDlg.cpp, SafetyAssignConsumerDlg.h
- SafetyConfirmAssignConsumerDlg.cpp, SafetyConfirmAssignConsumerDlg.h
- SafetyConfirmHeartbeat.cpp, SafetyConfirmHeartbeat.h
- SafetyModifyModeDlg.cpp, SafetyModifyModeDlg.h
- SafetyObjects.cpp, SafetyObjects.h
- SafetySadrConfirmDlg.cpp, SafetySadrConfirmDlg.h
- SafetyUnassignConsumerDlg.cpp, SafetyUnassignConsumerDlg.h
- SafetyUnconfirmDlg.cpp, SafetyUnconfirmDlg.h
- SafetyVerifNeuronIDDlg.cpp, SafetyVerifNeuronIDDlg.h
- SllEventSink.cpp, SllEventSink.h
- Some resources files

#### **4.5.9. WP 5.9 SAFETYLON Testbed**

##### **Objective**

The test bed in this work package is very important for the verification and validation process during the development of safe devices and systems and during product development of SMEs. It will cover additional tests that are normally not performed by TÜV within the device type approval process. The work package is part of the development of a set of tools to be used by accredited test laboratories in work package 3.3. Its primary objective is to allow enhanced testing of the device after completion of the TÜV device type approval for obtaining product certification by an authorized certification body.

##### **Description of Work**

These tests are only related to functional and network communication testing respectively. The secondary objective of work package 5.9 is to support the self-testing tools developed in work package 3.3 for SME partners and OEM developers to verify and validate their own development process and to prepare their products for testing as described.

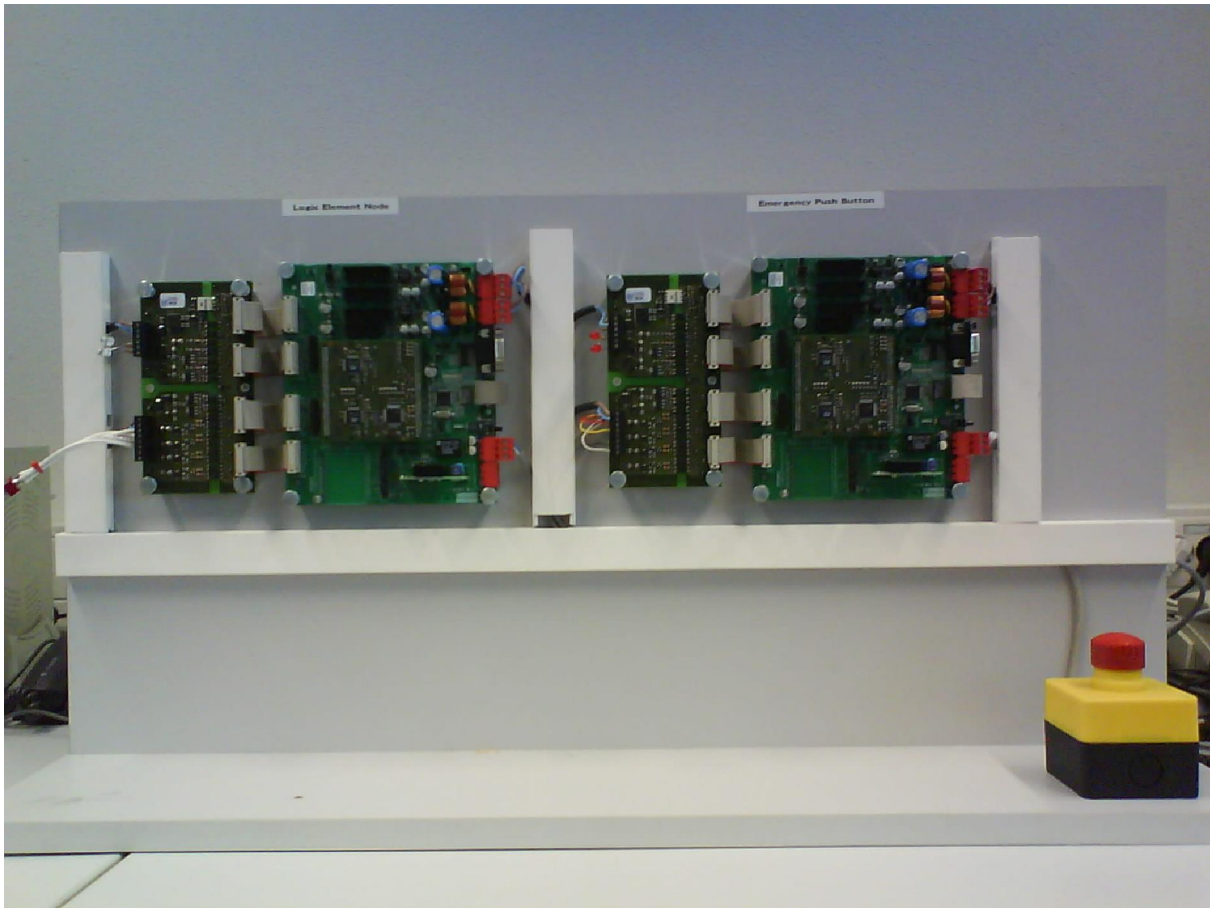
##### **Details of Period II**

In period II work package 3.3 has been commenced by AGH-UST and has made good progress. After specifying the test system, mainly by AGH, FH Dortmund has started to setup a local test environment of its own. Both universities are supporting each other to build up the same environment in Krakow and Dortmund in order to verify and make sure that the resulting test bed systems are identical and all tests can be flexibly transferred from one location to another. It is especially important in cases of unexplainable behaviour or results that tests can be replicated in the other location by different people.

##### **Details of Period III**

In period III work package 3.3. has been finalized by AGH-UST, also with the support of FH Dortmund which has set up a local test environment of its own. Like in period PII both universities have been cooperating and supporting each other to establish the same environments in Krakow and in Dortmund in order to verify and make sure that the resulting test bed systems are in fact identical and all tests can be flexibly transferred from one location to another. This is especially important in cases of unexplainable behaviour or results where tests must be replicated in the other location, respectively, by different people.

On the basis of the generic SAFETYLON test system, FH Dortmund has built up an application specific test bed. The test bed design description has been completed, the test bed itself has been set up and individual and dedicated tests have been performed. The application specific basis for the test bed has been provided by work packages 4.3 and 4.4 mainly because of the applications that have been described and finalized early enough to allow the setting up of the test bed within the scope of this project.



**Picture 4.5 – 32 SAFETYLON Test Bed for testing a safe sensor – actuator communication**

#### **4.5.10. Summary and Results**

In an iterative process RTD performers adapted their own specifications towards the needs of the SME's and vice versa. In this way the requirements and development plans became both more realistic and feasible with regard to design and implementation of marketable products. In addition, the system level requirements were challenged and are still being revised, if possible.

## **4.6. Work Package 6: Exploitation and Dissemination (IAGs)**

### **4.6.1. Exploitation**

The most important objective of the entire SAFETYLON project is to exploit and market the results of the RTD developments through the core SMEs and through other European companies

#### **4.6.1.1. TÜV Concept Approval (Part of WP1 and WP3) (Peter Wratil, Martin Mentzel)**

Several sessions have taken place between representatives of RTD performers Innotec (for WP1) and FH Dortmund (for WP3) and TÜV safety experts at TÜV Rheinland Industrie Service GmbH in Cologne. The concept approval started on April 3, 2006 on the basis of a fixed price quotation (9.500 € plus VAT) dated February 22, 2006. A set of requirements and design documents have been submitted including a SAFETYLON life cycle document and associated probability calculations regarding failure diagnosis and failure recognition. One important aspect of the concept approval pertains to a proposed new and innovative installation and commissioning procedure for SAFETYLON networks which poses an analytical and computational challenge for TÜV. Once granted the TÜV concept approval will be an important corner stone for the IAG licensing concept.

The TÜV concept approval has been received on September 15, 2006 which constitutes a major Milestone in our project (see Appendix A3)

#### **4.6.1.2. TÜV Assessment (Part of WP1)**

In order to give potential licensees of the SAFETYLON technology the security that the delivered RTD development results will reduce their own development process and make it affordable several meetings were scheduled in form of joint RTD and SME events. Moreover and under the leadership of INNOTEC it has been guaranteed that the development results are ready to be used for SME's and licensee's own product development to get a final type approval for these products. This certification process started on March 27, 2008 on the basis of a fixed price quotation (33,500 € plus VAT) dated February 7, 2008. All development documents, safety-related calculation documents and the core module prototypes have been submitted to TÜV Rheinland. In an accompanying process with support by INNOTEC TÜV Rheinland provided the report of the certification process for a generic SAFETYLON node on April 24, 2008. With this report TÜV Rheinland certifies that the development results are a good foundation for any type approvals of SAFETYLON products which actually is the desired result and final milestone of the SAFETYLON project.

#### **4.6.1.3. Patent (Part of WP 6.1)**

Although proposed and requested in the DoW there have been many controversial discussions in the various panel meetings about the value and the effectiveness of a patent to protect the IPR created by the Participating RTDs. Some contractors have had experiences with patents

---

in the past and were reporting on the rather questionable ratio of costs and effort versus the commercial benefit. In particular, when a patent is challenged by a large company it often becomes a matter of financial means whether to fight such a challenge in a patent court or not.

All three IAGs, however, took a pragmatic attitude that the primary objective of a filed – and eventually granted – patent must be the most important deliverable of a License Agreement in order to better protect the direct and indirect investments of a Licensee. For the RTDs and the SMEs it is now the accepted view that a patent would work as a kind of “umbrella” which not only protects the current developments of the SAFETYLON project but will also encompass further developments and improvements. Thirdly, it also provides an opportunity to precisely analyse and document what sets SAFETYLON apart from other safety solutions.

Fortunately, the most pertinent patents in the safety field have been provided by RTD performer Innotec such that a time consuming and costly patent search could be avoided. Although many aspects and features of safety architectures have already been invented and patented, e.g. for such well known industrial field busses like Profibus, CAN, Interbus and Ethernet/IDA, the LON system is a decidedly different network system which provides many new challenges for safety and therefore headroom for innovative patentable ideas. Among a number of claims (see Deliverable D3) the following claims appear to set SAFETYLON apart from the “crowd”:

- (1) safe multicast addressing: this addressing mode allows the simultaneous safe addressing and hence safe simultaneous communication of one “producer” node with more than one, i.e. many “consumer” nodes
- (2) the replication of at least one, all or additional services of the non-safe communication protocol in a SAFETYLON safety layer (SL)
- (3) the concept of a safe scenario involving the action of hundreds of safe or non-safe devices, which is executed over a certain period of time (concept of a “controlled shutdown”)
- (4) an innovative installation and commissioning method which involves non-safe, i.e. standard, proven-in-use, commercial tools
- (5) all architectural and implementation aspects that assure interoperability and conformance to an open SAFETYLON standard

A final patent has been filed with the European Patent Office on April 23, 2007 by the Munich patent office Samson und Partners. [The final patent has been placed in the Deliverables folder in CIRCA.](#)

#### **4.6.1.4 IAG panel meetings and decisions taken (PK as IAG panel leader)**

The IAG panel is the smallest panel, however, endowed with the biggest responsibility for the commercial success of SAFETYLON. It consists of two presidents of the user organisations LONMARK Sweden and Polish LON User Group (PLUG) and one board member of LONMARK Germany. The meetings are called and moderated by the Consortium Manager of LONMARK Germany. So far, the IAG panel has met three times and has worked hard to agree on the most important issues of exploitation and dissemination. However, some of the details of joint ownership and IPR licensing still need further work and clarification before the corresponding agreements can be drafted and signed. The target date presently scheduled is October 30, 2006.

---

The three IAGs have reached preliminary agreement on the following landmarks of a Joint Ownership Agreement (see more details in Deliverable D4):

- (1) the territorial responsibility as described in the DoW V2.0 (see Figure 4.6 - 1)
- (2) the sellable and deliverable content of the IPR generated by the RTD performers
- (3) three types of licenses for OEMs and Application Developers
- (4) a License pricing model
- (5) a revenue sharing model between the three IAGs for mutual support
- (6) a pay-back plan of the IAG co-financing to their respective organisations

All IAGs have informed the boards of their organisation and have received recognition and confirmation of these exploitation plans. [A signed version of the Joint Ownership Agreement will be placed in CIRCA as part of Period III reporting.](#)

#### **4.6.1.5. Exploitable IPR (MM as TPC)**

Exploitable IPR is generated in Work Packages 1 to 5 and can be defined as patentable or sellable documented knowledge. As specified in the EC Contract and the Consortium Agreement such IPR is transferred by the RTD performers to and then owned by the Industrial Association Groupings. It is therefore extremely important that the knowledge is documented to the highest standards, both from a technical (for developers and for technical personnel) and from a non-technical perspective (for marketing and sales engineers as well as for decision makers).

Since TÜV Rheinland is the first “customer” for SAFETYLON who requests both technically correct and complete, yet readable documentation, it performs the role of an external reviewer and quality assurance agent. Moreover, our patent lawyer is reviewing the documentation from a different angle making sure that the technical description and wording is comprehensible by a technically educated and open minded person, but not necessarily a communications or control networking specialist.

The main important IPR documents are:

- (1) The TÜV approved SAFETYLON concept documents (including certificate, scheduled for 09/06))
- (2) The final patent document filed at the European Patent Office in Munich (scheduled for 10/06)
- (3) Innovative installation and commissioning method document (part of TÜV approved concept; 09/06)
- (4) Safety Operating System (SOS) including Safety Layer (SL) documentation
- (5) [Example Application Specifications \(Emergency Push Button; Logic Element\). Note: all SME application specifications are, according to the Consortium Agreement, the IPR of the respective SME](#)
- (6) [enhanced and complete user documentation of the SOS including Safety Layer for product approval by TÜV, provided additional funding can be secured. Note: this item has been on](#)

the “wish list” of the PMC. However, at the end of the project there were no resources and funding available to begin or even complete this item

- (7) Training Kits and Material, Website, etc.
- (8) Comprehensive Documentation (see also Annex II of OEM Beta License Agreement, see Agreement 4.1 -1))

**4.6.1.6 Exploitable Products (MM as TPC)**

It is the intention of the Consortium to provide, during the course of the project, the grounds for an optimal start of SAFETYLON into the market. Therefore it is planned to build a number of products which will serve as reference designs for new OEM licensees as well as starting kits for new SME licensees. The following products are currently under design and will become the core products for future SAFETYLON hardware and application software developments:

- (1) SAFETYLON Core Modules
- (2) Installation and commissioning software
- (3) Testing software
- (4) Reference Application Kit, Neuron-FT3120 based
- (5) Reference Application Kit, LC 3020 based
- (6) Concept approval by TÜV Rheinland
- (7) SAFETYLON License Agreements for solution OEMs and Application Developers (SMEs) (see Beta License Agreement below)
- (8) TÜV certified Safety Operating System (SOS) including Safety Layer (SL), Source and Binary
- (9) SAFETYLON Interoperability Guidelines
- (10) see also Annex II of OEM License Agreement

Products (1) to (7) are part of the current project, products (8) and (9) are subject to consecutive funding.

**NON-EXCLUSIVE BETA LICENSE AGREEMENT**

**between**

**LONMARK Deutschland e.V.**  
**- hereinafter Licensor -**  
**represented by its chairman of the board .....**

**and**

.....  
**- hereinafter Licensee -**  
**represented by its ..... (e.g. managing director; chairman of the board; .....**)

**The following is agreed upon:**

**PREAMBLE**

**I** The European Community EC funded a collective research project called SAFETYLON. The objectives of SAFETYLON included, inter alia, research and development activities with respect to provide platform-technology for interoperable safety related data transfer in automation control environments, implementations of safety standard IEC 61508, fail-safe communication in local operating networks and establishing local operating network LON technology in safety related applications beyond building automation.

It has been agreed upon that results emerging from SAFETYLON shall be disseminated and exploited, particularly by means of licensing knowledge, know-how and intellectual property including hardware and software related results (e.g. hardware design, chip design and layout, software source code).

The official project term of SAFETYLON terminated on 22 May 2008.

However, the object of SAFETYLON to provide, at its project term's end, a basis for actual practical implementation of project's results particularly in form of commercial products and services was not completed to full extent. Although most of the project's results are sufficient for such a basis, in some research and development areas of SAFETYLON further activities will be necessary that such a basis will be available there also. This particularly applies to the areas of embedded software and testing environment.

Therefore, said exploitation and dissemination is presently limited to the status-quo prevailing at the project term's end.

**II** Licensor was an actively participating member of SAFETYLON, particularly a so-called Industrial Association Group IAG. As IAG, Licensor owns Intellectual Property Rights concerning research and development work performed in the framework of SAFETYLON and was in the framework of SAFETYLON responsible for exploitation and dissemination of results emerging from SAFETYLON. To this end, a European patent application has been filed:

|  |                 |
|--|-----------------|
| Official Application number of the European Patent Office: | 07 008 251.6    |
| Filing date:   | 23 April 2007   |
| Priority date:   | 21 April 2006   |
| Published on:  |                 |
| Publication number:  | EP 1 850 554 A2 |

Copy of the publication of this European patent application is enclosed as Annex I.

Licensor is sole applicant of this European patent application.

Licensor has explicitly expressed the ongoing obligation to actively support exploitation and dissemination of results. This includes licensing of said European patent application and provision of documents, documentation, software source code and any other information relating to hardware and software resulting from SAFETYLON - the latter, in view of the not fully completed research and development areas of SAFETYLON, however presently limited to the status-quo prevailing at the project term's end.

Licensor has also explicitly expressed the wish to at least initiate, preferably carry out, follow-up research and developments activities particularly with respect to not fully completed research and development areas of SAFETYLON - particularly in order to achieve a basis for interoperability. Such activities may be initiated or carried out in cooperation with other former members of SAFETYLON. Results of such activities may be provided to Licensee for use in research and development activities of Licensee.

**III** Licensee is positively aware of the fact that the results of SAFETYLON include not fully completed research and development areas and that therefore no basis for actual practical implementation of SAFETYLON project's results particularly in form of commercial products and services is presently available. In the light of this situation, Licensee knows that further research and developments activities particularly with respect to not fully completed research and development areas of SAFETYLON will be necessary and that such activities have to be performed by Licensee, especially for aspects specific for products, applications, services and the like of Licensee. For such activities, support may be requested from Licensor, for example in form of contacts to and/or cooperation with other former members of SAFETYLON.

Results of research and development activities of Licensee as well as possible intellectual property and/or intellectual property rights resulting therefrom belong to Licensee without any obligation to inform or even provide Licensor of such assets; this particularly applies to aspects specific for products, applications, services and the like of Licensee. However, Licensee may provide research and development activities' results to Licensor, particularly in the case of aspects related to interoperability.

**IV** For dissemination and exploitation of present SAFETYLON results the following licensing principles should be used:

- Licenses shall be non-exclusive, a royalty-free and fully paid (one time license fee).
- The one time license fee shall be - in view of the not fully completed research and development areas of SAFETYLON - rather low compared with a one time license for implementation ready research and development results.
- Licenses shall not include the right to grant sub-licenses.

In the framework of this agreement, Licensor will provide to Licensee all documents, documentation, software source code and any other information relating to hardware and software resulting from SAFETYLON as far as presently available.

By this agreement, Licensee shall have the right to develop, produce and market products using knowledge, know-how and intellectual property as well as intellectual property rights resulting from SAFETYLON and services related to such products.

**V** For the sake of completeness it is noted that any other former IAG of SAFETYLON alone may enter a license agreement

in line with the premises, condition and regulations set forth in the present agreement with any other third party. The other former IAGs are LON User Sweden and Polska Gurpa Uzytkownikow Technologii LONWORKS.

Also it is noted that any party having participated in the SAFETYLON project is according to contractual agreements within the framework of SAFETYLON, automatically entitled to use all results of SAFETYLON including documents, documentation, software source code and any other information relating to hardware and software and is automatically granted a non-exclusive license on knowledge, know-how and intellectual property as well as intellectual property rights resulting from SAFETYLON.

VI Licensor intends, if applicable, to offer an upgrade license agreement for the present agreement or an further license agreement in addition to or in place of the present agreement if a basis for actual practical implementation of results of SAFETYLON particularly in form of commercial products and services will be achieved.

Based on these premises, the parties agree as follows:

## § 1 Definitions

The terms used in the agreement shall have the following meanings:

(1) "Licensed Rights" means

- (1.1) - European patent application 07 008 251.6,  
 - all European divisional patent applications claiming the priority of European patent application 07 008 251.6,  
 - all national parts of a European patent based on European patent application 07 008 251.6,  
 - all national patent and utility model applications based on European patent application 07 008 251.6, and  
 - all national patents and utility models based on European patent application 07 008 251.6.

(1.2) The trademark "SAFETYLON" filed with the Office for Harmonization in the Internal Market (OHIM) and having the official trademark number 006 939 979.

(2) "Licensed Know-How" means non-patented information resulting from the SAFETYLON project, which is:  
 i) secret, i.e. information not generally known or easily accessible,  
 ii) substantial, i.e. information significant and useful for the development, production and marketing of Licensed Subject-Matter, and  
 iii) identified, i.e. described in a sufficiently comprehensive manner so as to make it possible to verify that it fulfils the criteria of secrecy and substantiality.

(3) "Deliverables" are finally defined in ANNEX II.

(4) "Licensed Subject-Matter" means any hardware product, software product and service, which falls under a claim of any of the Licensed Rights and/or implements one or more Deliverables.

(5) "Connected Undertakings" means

- (a) undertakings in which Licensee, directly or indirectly,  
 (i) has the power to exercise more than half the voting rights, or  
 (ii) has the power to appoint more than half the members of the supervisory board, board of management or bodies legally representing the undertaking, or  
 (iii) has the right to manage the undertaking's affairs;
- (b) undertakings which directly or indirectly have, over Licensee, the rights or powers listed in (a);
- (c) undertakings in which an undertaking referred to in (b) has, directly or indirectly, the rights or powers listed in (a)
- (d) undertakings in which Licensee together with one or more of the undertakings referred to in (a), (b) or (c), or in which two or more of the latter undertakings, jointly have the rights or powers listed in (a);
- (e) undertakings in which the rights or the powers listed in (a) are jointly held by  
 (i) Licensee or Licensee's respective connected undertakings referred to in (a) to (d), or  
 (ii) Licensee or Licensee's respective connected undertakings referred to in (a) to (d) and one or more third parties.

## § 2 Non-exclusive License

- (1) Licensor grants a non-exclusive license for development, production and marketing of Licensed Subject-Matter.
- (2) Licensor has the right to grant further non-exclusive licenses to third parties.
- (3) Licensor maintains the right of development, production and marketing of Licensed Subject-Matter in the License Territory as defined in § 3.

## § 3 License Territory

The license is granted worldwide.

## § 4 Field of License

The license covers the entire area of any possible application of Licensed Subject-Matter including technical developments and improvements thereof.

## § 5 Assignment of the License Agreement

- (1) This License Agreement and the rights and obligations hereunder shall not be assignable by Licensor whether by merger, divestiture, acquisition, operation of law or otherwise without prior written consent by Licensee. Such a consent shall not be unreasonably withheld.
- (2) This License Agreement and the rights and obligations hereunder shall not be assignable by Licensee whether by merger, divestiture, acquisition, operation of law or otherwise without prior written consent by Licensor; this particularly applies to Connected Undertakings. Consent by Licensor for assignment shall not be unreasonably withheld.

## § 6 Sublicenses

Licensee is not allowed to grant sub-licenses. This also applies to Connected Undertakings

## § 7 Licensing of Know-How and Deliverables

- (1) Licensor shall make available to Licensee Know-How and Deliverables for utilization by Licensee.
- (2) Licensor will transmit respective documents, documentations and, where applicable, hardware and software within one month after payment of the license fee agreed upon in § 9.
- (3) Licensee is obliged to keep any Licensed Know-How and Deliverables as well as any further information in written or oral form confidential.
- (4) Licensee shall have employees and suppliers to keep, as far as they will be granted access, Licensed Know-How and Deliverables and any information provided by Licensor confidential.
- (5) Licensee shall have the right to have Licensed Subject-Matter produced by third parties in form of subcontractors. To this end, Licensee shall have the right to provide information, which is necessary for producing Licensed Subject-Matter, to subcontractor including Licensed Know-How and Deliverables. Licensee is obligated to have all subcontractors receiving such information to keep this information sign confidential.
- (6) After expiration or termination of the present license agreement, all materials as well as copies and reproductions thereof provided hereunder by the Licensor to Licensee shall be returned to Licensor within three (3) months after expiration or termination, respectively, including information provided subcontractors for producing Licensed Subject-Matter.
- (7) After expiration or termination of the present license agreement, Licensee shall continue keeping any information obtained from Licensor confidential; this includes subjecting employees and suppliers of Licensee to this confidentiality obligation. This obligation continues for as long as Licensed Know-How and Deliverables and any further information provided by Licensor have not become accessible to the public. In the case of subcontractors for producing Licensed Subject-Matter, Licensee is obligated to subject the subcontractors to this confidentiality obligation also.

## § 8 Liability

- (1) Licensor guarantees neither patentability nor validity of the Licensed Rights nor commercial exploitability of Licensed Subject-Matter and shall not be liable accordingly.
- (2) Licensor does not guarantee that development, production or marketing of Licensed Subject-Matter will be free from infringement of any patent or intellectual property right of a third party and shall not be liable accordingly.
- (3) Licensor shall have no obligation to provide any support or technical assistance under this license agreement.

## § 9 License Fees

- (1) Licensee pays a one-time license fee of € 10,000.00 (ten thousand Euro).
- (2) Licensee shall pay the total sum of License Fees according to § 9 (1) within one (1) month after signing this License Agreement.
- (3) Any payments of Licensee hereunder shall be non-refundable under any circumstances including termination of this License Agreement for any reason.

## § 10 Product Liability

Licensee indemnifies Licensor with respect to any claims of third parties based on product liability. Licensee also holds Licensor harmless for any claims of third parties based on statements by Licensee with respect to Licensed Subject-Matter. Licensee further holds Licensor harmless for any claims of third parties based on infringement of any patent and other intellectual property right by Licensee.

## § 11 Infringement and Litigation

- (1) Licensor and Licensee will inform each other of any infringement of Licensed Rights in the territory agreed hereunder.

Licensor is not obligated to proceed against infringers of Licensed Rights, but Licensor shall support Licensee in the enforcement of Licensed Rights and particularly shall provide Licensee, upon request, with the necessary procedural powers.

- (3) Licensor is not obligated to defend Licensed Rights against validity challenges by third parties, but Licensor shall support Licensee in the defense of Licensed Rights and particularly shall provide Licensee, upon request, with the necessary procedural powers.

## § 12 Lapse and Invalidity of Licensed Rights

Expiration, lapse and invalidation of one or more of Licensed Rights leaves this License Agreement unchanged and does not result in any refunding of License fees from Licensor to Licensee.

## § 13 Term

- (1) This license agreement comes into existence upon signing by Licensee and Licensor and shall have a duration of seven and a half (7.5) years beginning with the signing date.
- (2) This license agreement shall end before the term according to § 13 (1) at the date at which both the last of the Licensed Rights is not effective anymore and all Licensed Know-How has become accessible to the public except in the event Licensed Know-How becomes publicly known due to action by Licensee.

## § 14 Termination

In the case of a breach or significant violations of this license agreement Licensee and Licensor shall have the right to terminate this License Agreement of cause. This right shall be exercised within one (1) month from notice of the breach or violation, respectively.

## § 15 Applicable Law and Legal Venue

This License Agreement shall be governed and construed under the laws of the German Federal Republic.

All disputes or claims concerning this License Agreement shall be subject to the jurisdiction of the District Court Düsseldorf.

## § 16 Severability

Should any provision of this License Agreement be invalid or unenforceable or should this License Agreement include an omission, the remaining provisions shall be valid. In the place of an invalid provision, a valid provision is presumed to be agreed upon by Licensor and Licensee, which come economically closest to the one actually agreed upon; the same should apply in the case of an omission.

## § 17 Formal Provisions

- (1) This License Agreement has been drafted in English.
- (2) The present text contains the entire license agreement between Licensor and Licensee; any changes of this License Agreement shall be made in writing.

.....  
Place, Date .....

.....  
... (Licensor) represented by ...

.....  
Place, Date .....

.....  
... (Licensee) represented by ...

### Enclosures:

- Annex I (EP 1 850 554 A2)
- Annex II (definition of deliverables)

## Agreement 4.6 – 1 The Non-Exclusive Beta License Agreement

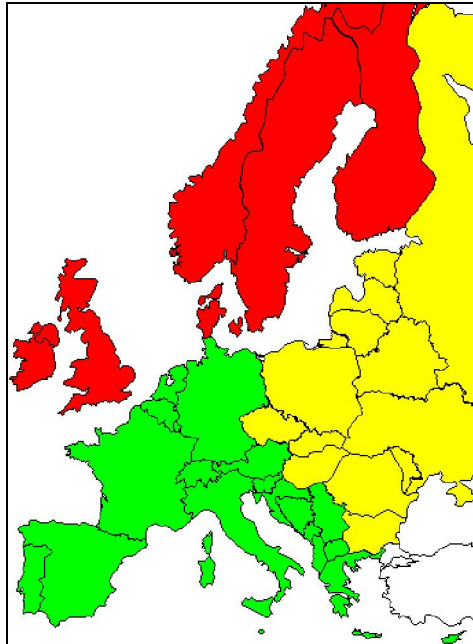
## 4.6.2. Dissemination (PK, AB, JH/MM contributions for their respective territories)

### 4.6.2.1. Objective

By EC contract and Consortium Agreement the dissemination of the SAFETYLON IPR is the task of the three Industrial Association Groupings LONMARK Germany (LMD), LONMARK Sweden (LMS) and Polish LON User Group (PLUG). An appropriate definition of dissemination would be the following: to take all measures and engage in all activities to market and sell the results of the research and development work of the RTDs in order to make SAFETYLON an open European standard for safe communication and networking. In addition, it comprises all activities to market and sell the products including licenses of 3.6.1.5 to the broadest possible customer base.

### 4.6.2.2. Territories

In order to cover the European territory in an optimal way with the limited resources available the three IAGs have decided to follow the proposal of the DoW to assign marketing and sales responsibilities in accordance with the three colored regions. Each IAG has already built a plan which starts in the respective home countries (Germany, Poland, and Sweden/Norway).



**Figure 46 - 1: Responsibilities for dissemination and training for the three participating IAGs: **NORDIC** (LUS), **CENTRAL** (LMD), **EAST** (PLUG),**

The details of this agreement will be documented in a Joint Ownership Agreement to be signed by the three IAGs not later than October 2006. Some of the important clauses of the Joint Ownership Agreement are:

- The assignment of responsibilities for each region
- The conveyance of identical content in various languages
- Identical License Agreements in English language including European arbitration
- Collaboration on important SAFETYLON prospects and customers
- The distribution of license revenue between the three IAGs
- Involvement of other local User Organisations in the dissemination process
- A body replacing the IAG panel after completion of the project
- Clauses that define the responsibility for ongoing development
- Clauses that define the support obligations of the IAGs for customers in their region.
- Duration until 31.12.2010 with automatic annual prolongation if not terminated by any IAG.

The Agreement [was](#) drafted with the help of a lawyer experienced in European law and will be paid by the three IAGs in proportion to their eligible costs excluding WP8.

[Because of its importance for the continued cooperation of the IAGs the full text of the JOA is shown below:](#)

#### 4.6.2.3 Dissemination Material

As one of the first activities a SAFETYLON logo has been created which has been widely accepted by all the consortium members. It features black stripes on a yellow background which is an international symbol for danger or alarm. The SAFETYLON font is simple and leaves the viewer with a strong impression. The logo was first shown to the public on the panel in Picture 4.6 - 2: Panel on display during the Light & Building in Frankfurt in April 2006 which also displays the logos of the other main important partners in the project, the EU, TÜV, and LONMARK Germany. It was well received.



**Picture 4.6 - 2: Panel on display during the Light & Building in Frankfurt in April 2006 and on Hanover Fair 2007 in April 2007**

---

In its last IAG panel meeting it was decided that a Europe-wide text and picture mark shall be obtained for this logo jointly financed by the three IAGs.

Further collateral that was produced for the Light&Building 2006 tradeshow in Frankfurt and for Hanover Fair 2006 was a flyer in German and English language. This flyer will be translated into Swedish, Polish, Italian and French in due time for similar events. Also, a set of PowerPoint presentations have been put together in German and English which will also be translated into four other European languages.

In a brochure "How to find partners for research, development and innovation", in the chapter "Frame Programs – experience in realization" a success story of our Polish partners in the SAFETYLON project was published and 620 pieces were distributed.

Information about the project is currently being placed in the Polish database [www.innowacje.malopolska.pl](http://www.innowacje.malopolska.pl).

#### **4.6.2.4 Presentations on Public Events (PK, AB, JH/MM contributions for their respective territories)**

Particular care has been taken to avoid the conveyance of any IPR associated with the patent registration. Therefore the dissemination activities in the early phases of the project were restricted to general messages and to the promotion of the Collective Research project. However, after the final filing of a preliminary European patent on April 23, 2007 we are now beginning to be fully open about the SAFETYLON hardware and software architecture and the installation and commissioning procedure. [The first truly open announcement was done on the IEEE INDIN 2007 Conference in Vienna \(the annual conference of the IEEE society\). In three papers and a 4 hour tutorial at least 100 visitors learned about SAFETYLON for the first time.](#)

Aside from many such instances on internal events of the Lon User Groups the following presentations and tradeshow had an official character:

- to General Assembly of LONMARK Germany in 09/2006 (60 attendees)
- to General Assembly of LONMARK Sweden in 03/2007 (65 attendees)
- to General Assembly of Polish Lon Users in 06/2006 (28 attendees)
- to a national audience at the Hi-Tech House tradeshow in Moscow in 11/2006 (1 hr Tutorial; 50 attendees)
- exhibition booth on Hannover Fair 2007 (April 2006, 5 days, about 30 presentations)
- on the ELFACK tradeshow in Gotenburg (5 days in May 2007): endusers, integrators, consultants
- Building Automation Seminar in Stockholm (May, 2007; presentation Anders Blom, about 60 attendees)
- seminar at BUD-GRYF in Szczecin (March 31, 2007, presentation of Pawel Kwasnowski and Jerzy Michalski to approx. 30 attendees)
- further activities of AGH-UST:
  - Presentation of current state of the SAFETYLON Project at AGH-UST internal seminar
  - Preparation information materials for potential hosts of future seminars and trainings
  - Talks with potential hosts of future seminars and trainings.

- 
- 3 papers prepared, and accepted for IEEE INDIN 2007 conference (July 2007)
  - 6 presentations prepared and submitted as handouts for Tutorial on IEEE INDIN 2007 conference (July 2007)

The feedback from tradeshow visitors has been extremely positive and encouraging. Most of them have requested and received a copy of the presentations. Some of them were seriously interested and will be offered a License Agreement in due time.

#### **4.6.2.5. Planned events for Period III (Outlook) (PK, AB, JH/MM contributions for their respective territories)**

- A 4 hour SAFETYLON Tutorial was given at the IEEE INDIN Conference 2007 by the CM, three RTD representatives and the SME panel leader. Among many students there were also representatives from Siemens Germany , Siemens Switzerland and the German VDMA (Verband Deutscher Maschinen- und Anlagenbauer)
- 3 papers on SAFETYLON were given by Prof. Peter Fischer / Martin Mentzel, Dr. Peter Palensky and Dr. Grzegorz Hayduk. The printed version will be available for download from the SAFETYLON Website
- The following series of seminars is currently being planned and prepared:
  - LMD: Zürich, Bern, Vienna, Stuttgart, Düsseldorf, Hamburg
  - LMS: Stockholm, Helsinki, Oslo, Copenhagen
  - PLUG: Krakow and Warsaw
- Tradeshows on which we plan to attend or present:
  - LonWorld 2007 in Amsterdam (11/2007)
  - Light & Building 2008 in Frankfurt (April 2008), biggest international tradeshow in Building Automation. On this event we plan a “big” announcement
  - NORDBYGG Building Automation Fair in Stockholm
  - Building Industry and Building Automation Fair TARBUŁ - Wrocław 7-9.03.2008 (also exhibition participation planned)
  - Automaticon Fair - Warszawa 1-4.04.2008 (also exhibition participation planned)
  - Wrocław Technical University – Center of Technology Transfer - first half of November 2007
  - Warsaw Technical University - second half of April 2008
  - Warsaw – Industrial Institute for Automation and Measurement (PIAP) - second half of October 2007
  - AGH-UST Krakow – second half of October 2007
- Publications:
  - Special Topic in the LONMARK Magazin (09/2007)
  - Special Topic in LONMARK Magazine European Edition (11/2007, issue for LonWorld)
  - Replications / reprints of the SAFETYLON “feature and benefit” articles in various formats in a number of European trade magazines
  - Interviews with the trade press
- SAFETYLON website: at this point the format of the Website is already demonstrable internally. It is planned to start the website officially on October 1, 2007. by then we should have prepared sufficient content.

---

**4.6.2.6 Next Steps (PK, AB, JH/MM contributions for their respective territories)**

The most important next step will be

(1) the drafting, discussion and ratification of the Joint Ownership Agreement and the Licensing Agreement on the next IAG panel meetings in the fall, 2007. After these meetings we will also begin with a detailed resource, cost, marketing and execution planning for the three territories.

With regard to dissemination the following activities have been planned and are currently in preparation:

(2) launch a professional Website

(3) identify or buy qualified address material of potential prospects (e.g. LMD has contracted TEMA to buy such material, we expect several hundred addresses)

(4) prepare and execute a series of some 15 seminars in Europe between 10/2007 and 5/2008 in cooperation with the respective LON User organisation

(5) identify and carry out 2 to 3 seminars or inhouse workshops at prospects. Each IAG will identify its best prospects.

(6) identify one pilot OEM per region as pilot or alpha customer whom we will give a sizeable discount (e.g 50% or more) to get started and who will be benevolent during the development, beginning in month 33 (e.g. Honeywell, Hybryd, TAC). Each IAG will identify his best prospects.

(7) 2-3 publications in trade journals per region. The first publication will come from LMD in the LONMARK magazine in German and English

(8) SAFETYLON press conference on Light & Building (all three IAGs will participate) where TEMA invites European journalists. This could, e.g. be done in conjunction with the LMD press conference, or separately.

(9) a 2-3 hour Tutorial (like the one held at IEEE INDIN 2007) as part of every 2 day training workshop. This will be a contribution of LMD to the training program.

(10) personal contacts / visits at one or two major trade associations per region (e.g. VDMA, VdS, TÜV Nord). Each IAG will identify his best prospects.

(11) write a comprehensive technical White Paper on SAFETYLON (in English) which is introductory and mandatory reading for any engineer who is going to work with SAFETYLON. This white paper will be prepared by LMD (e.g. Martin Mentzel, Peter Wratil, Jürgen Hertel) and published in one of the following issues of LONMARK Magazine (first half of 2008). It can also be downloaded from the SAFETYLON website. All three IAGs will take care of translations for their respective territories.

[Execution on the "Next steps" PII plan in Period PIII: \(the numbers in \(\) refer to the points in the PII report in the same section\)](#)

---

(1) The Joint Ownership Agreement has been finalized and ratified by all three IAG boards (see Figure 4.6 – 3). Also a Beta SafetyLon License Agreement has been completed (see Agreement 4.1 - 1)

(2) The Website [www.SAFETYLON.de](http://www.SAFETYLON.de) has been filled with content, and is now in the process of being launched. Due to the fact that there is still an unpaid invoice we only there is currently an internal access only. This will be changed to public accessibility after the final payment to aimcom. In the meantime, as an assigned responsibility of the Joint Ownership Agreement the Joint Ownership Exec Committee (JOEC) has taken the responsibility to enhance the content and maintain the quality and actuality of the site. The page on the EU project SAFETYLON is shown in picture 4.6 -3.

(3) TEMA has in fact purchased more than 1.000 qualified addresses which were used for two mailings to invite engineers and decision makers to our series of seminars and training workshops. In addition 2 advertisements were placed in the LONMARK Magazine, European Edition, in November 2007 and January 2008.

(4) In total about 20+ seminars and workshops were held in Europe. The locations can be seen in the full page ad (see Figure 4.6- 4 which was placed twice in the LONMARK Magazine

(5) in such inhouse seminars / tutorials were given to the following companies:

- MST (a Honeywell company): safe monitoring of toxic gases (G)
- TROX : safe control of fire fighting and smoke extraction dampers (G)
- Dräger: monitoring of toxic gases (G)
- Belimo: safe control of fire spreading and smoke extraction dampers (CH)
- Hybrid: safe control of fire alarm and fire fighting systems (PL)
- TAC (Group Schneider): safe Building Management (S)

In addition, a number of individual training sessions were scheduled during the Light & Building 2008 tradeshow.

(6) All companies listed under (4) are still on the “warm” to “hot” list and are being followed up by

- Innotec, who and SafeSquare (startup founded by the owners of Innotec and WHO in order to promote SAFETYLON and offer consulting and development services (G)
- IBT and Loytec (CH and A)
- Zdania (PL), who also continues to cooperate with AGH-UST and PLUG, of course.
- Naronic (S)

Many discussions revealed that the most difficult and time consuming element in coming to a technical solution and a decision by the technical and commercial management is the assessment of the total costs of a safe development and the lack of trained personnel for IEC 61508 compliant Functional Safety Management. A second element is the currently still unclear situation about the future dominance of the European standards like IEC 61508 and IEC 61511 over local standards, and the time frame during which the transition will occur.

(7) LONMARK Germany placed one article in German and the same article in English split in two parts in the German language LONMARK Magazin and the LONMARK Magazine Europe, respectively. These articles served as templates for articles that were later published in local

---

LON publications in Poland and Sweden. The articles are part of Deliverable D4 and D16 respectively.

(8) A press conference was held during Light & Building on April 8, 2008 (see Pictures 4.6-10 and 4.6 – 11). As a result approx. 15 articles were published in the trade press).

(9) a 2 hour tutorial (like the one held at IEEE INDIN 2007 conference in Vienna, May 2007) as part of every 1 day training workshop. This English language contribution– as well as several others modules - was the LMD contribution to the training program which was subsequently translated into Polish and Swedish.

(10) personal visits were scheduled with TÜV Rheinland (Joerg Krämer, Erich Janoschek) also due to the fact that this institution has been commissioned with the assessment / certification of our work. Further, personal contacts were established with TÜV Nord (Gerhard Rieger) and to ZVEI (Wilfried Brandt). Similar contacts have been established in Poland and Sweden.

(11) a technical White Paper in the broadest and fully comprehensive sense has not been completed until today, mainly due to lack of funding. It will be published in the first quarter of 2009 with joint authorship of Martin Mentzel, Peter Wratil and Jürgen Hertel. However, one PhD thesis (Thomas Novak) and two Diploma works (B.Sevcik, P. Preininger), as well as scientific papers published by the ICT development team testify of the thorough R&D performer by ICT, Vienna (see complete list in section 4.2.3)

Following is a series of pictures illustrating some of the Deliverables and events that have taken place in Period PIII as part of WP 6.



## JOINT OWNERSHIP AGREEMENT Final version dated 11.08.2008

Between:

LONMARK Sweden  
När Prästgården 201  
62348 Stånga  
Sweden  
(LMS)

Polska Grupa Uzytkownikow Technologii LONWORKS  
ul. J. Lea 116, lok. 67  
30-133 Krakow  
Poland  
(PLUG)

LONMARK® Deutschland e.V.  
Theaterstraße 74  
52062 Aachen  
Germany  
(LMD)

each referred to as "Party" in the following.

### PREABMLE

Each of the parties has actively participated in a project called SAFETYLON, a project under the 6th framework program of the European Community, as IAG (Industrial Association Group) partner. According to the consortium agreement for the SAFETYLON project, the IAG partners jointly own intellectual property of the SAFETYLON project and are responsible for exploitation and dissemination of such intellectual property.

The parties in their function as IAG partners have filed the European patent application . 07008251.6-1244. Each of the parties is named as applicant of said European patent application. The present joint ownership agreement shall be the basis for prosecution of said European patent application and possible intellectual property applications based thereon and maintenance and exploitation of intellectual property rights, particularly patents, granted on said European patent application and, if applicable, on intellectual property applications based thereon.

### § 1 Definitions

"Agreement" shall mean this Join Ownership Agreement.

"Intellectual Property Application" shall mean the European patent application 07008251.6-1244 and any intellectual property application based on said European patent application, such as divisional European patent application(s), national patent application(s) and national utility model application(s).

"Intellectual Property Right" shall mean any intellectual property right granted on the European patent application 07008251.6-1244 and on any intellectual property application based on said European patent application, such as national patent(s) of a European granted on said European patent application and, if applicable, divisional European patent application(s), national patent application(s) and national utility model application(s) based on said European patent application. In addition, all licenseable results of the SAFETYLON project are part of the intellectual property right.

### § 2 Joint Ownership

Each of the Parties shall have an equal interest in the Intellectual Property Application and the Intellectual Property Right.

### § 3 Representation

The Parties shall be represented with respect to a third party in the case of issues related to prosecution of the Intellectual Property Application and validation and maintenance (including litigation) of the Intellectual Property Rights, such a patent offices, patent attorneys, lawyers, annuity services, by the Representing Party LONMARK® Deutschland e.V.

For cases of exploitation, particularly licensing of the Intellectual Property Right, the Parties herewith agree that each party may act without further consent or approval by the remaining Parties with respect to a third party, such as possible licensees.

**§ 4 Assignment**

A Party is not allowed to assign its interests in the Intellectual Property Application and/or Intellectual Property Right to a third party before written approval by the remaining parties.

In the case a Party assigns its interests in the Intellectual Property Application and/or Intellectual Property Right to a third party without written approval by the remaining parties, said party has to pay a contractual penalty of 1 Mio Euro to each of the remaining parties.

**§ 5 Insolvency or Liquidation**

In the case of insolvency or liquidation of a Party, the remaining Parties shall have the right to terminate this agreement without consent of the insolvent Party or its legal successor.

**§ 6 Prosecution of Intellectual Property Application**

Prosecution of the Intellectual Property Application shall be accomplished by the Representing Party named in § 3.

**§ 7 Divisional Applications**

Any divisional application based on the European patent application 07008251.6-1244, such as divisional European patent application(s), national patent application(s) and national utility model application(s), shall be filed by the Parties upon unanimous decision.

In the case no unanimous decision is made on a divisional application, the remaining Party or Parties may file that divisional application in its name or their names and on its or their costs, respectively. The Party or Parties not interested in the divisional application shall provide the necessary procedural powers to the filing Party or Parties.

**§ 8 National Validation**

The parties shall agree unanimously on the states in which the Intellectual Property Right is to be validated. Costs for validation are shared by the Parties equally.

In the case no unanimous decision is made with respect to validation in a state, the remaining Party or Parties may effect validation in that state in its name or their names and on its or their costs, respectively. The Party or Parties not interested in the validation shall provide the necessary procedural powers to other Party or Parties.

**§ 9 Maintenance of the Intellectual Property Right**

The Parties shall maintain the Intellectual Property Right in each state for the respective maximum duration of protection. Maintenance costs shall be shared by the Parties equally.

In the case no license agreement on the Intellectual Property Right is still in force, the parties may abandon the Intellectual Property Right.

In exceptional cases, the Intellectual Property Right may be abandoned in a state or states upon by unanimous decision by the Parties. Such a decision shall particularly take into consideration pending license agreements.

**§ 10 Infringement and Litigation**

The Parties shall inform each other on any infringement of the Intellectual Property Right. In case of infringement, the Parties will decide whether or not infringement litigation is to be pursued particularly in view of possible effects on pending license agreements. Costs of an infringement litigation will be born by the pursuing Party or Parties. Received damage payments will be entitled to the pursuing Party or Parties.

The Parties may provide one or more licensees with the necessary procedural powers to pursue an infringement litigation. Here, costs of an infringement litigation will be born by the pursuing licensee(s). Received damage payments will be entitled to the pursuing licensee(s).

**§ 11 Licensing of Intellectual Property Right and Know-How**

The Parties will exploit the Intellectual Property Application and the Intellectual Property Right as well as associated know-how by licensing.

The Parties agree that each Party may grant a license under the Intellectual Property Right without prior consultation of the other parties. The licensing Party will be provided the necessary procedural power by the other Parties.

The Parties agree to establish a Joint Ownership Executive Committee (JOEC) consisting of one member from each Party to execute this Agreement.

Members of JOEC are responsible of communicating all matters of IPR and license business. For example, the JOEC shall be responsible for maintaining the SAFETYLON website, assuring comparable services like ongoing development, marketing, sales, support and training to licensees in the three territories NORDIC, EAST and CENTRAL, as defined in the SAFETYLON "Description of Work" document.

The Parties agree that other members of the SAFETYLON project will be granted a full license free of charge.

**§ 12 Distribution of Revenues from Exploitation**

Revenues from exploitation of the Intellectual Property Application and the Intellectual Property Right shall be distributed among the Parties, details to be worked by the Joint Ownership Executive Committee (JOEC).

Distribution of revenues from any other form of exploitation shall be agreed upon by the Parties separately in writing.

**§ 13 Term**

The Agreement comes into existence upon signing by all parties. The Agreement and all its obligations ends with the latest of a refusal of the last of the Intellectual Property Application and an expiration of last to the Intellectual Property Right.

In the case no license agreement on the Intellectual Property Right is still in force, the parties may terminate the Agreement upon mutual consensus.

**§ 14 Termination**

In case of significant violations of the Agreement, each Party may have the right for termination for cause, which has to be exercised within four weeks. Significant violations include assignment of the interests of a Party in the Intellectual Property Application and/or the Intellectual Property Right to a third party without agreement among all Parties, noncompliance with regulations concerning costs and revenues, and bankruptcy or insolvency of a Party.

Termination of the Agreement may subsequently require changes in the assignment of the Intellectual Property Application and/or the Intellectual Property Right. The Party, which has caused the termination by violation of the Agreement, shall support the other Parties in such assignment changes; failing to do so, a contractual penalty has to be paid.

**§ 15 Applicable Law and Place of Venue**

The Agreement shall be construed according to the laws of the Federal Republic of Germany.

The Parties agree that for all controversies or claims the District Court Munich I (Landgericht München) shall have jurisdiction.

**§ 16 Salvatorian Clause**

Should any provision of this Agreement be invalid or unenforceable or should the Agreement include an omission, the remaining provisions shall be valid.

In the place of an invalid provision, a valid provision is presumed to be agreed upon by the Parties, which comes economically closest to the one actually agreed upon. The same shall apply in the case of an omission.

**§ 17 Form Provision**

This Agreement contains the entire provisions and agreements between the Parties. Any changes of the Agreement have to be made in writing.

Date:

Date:

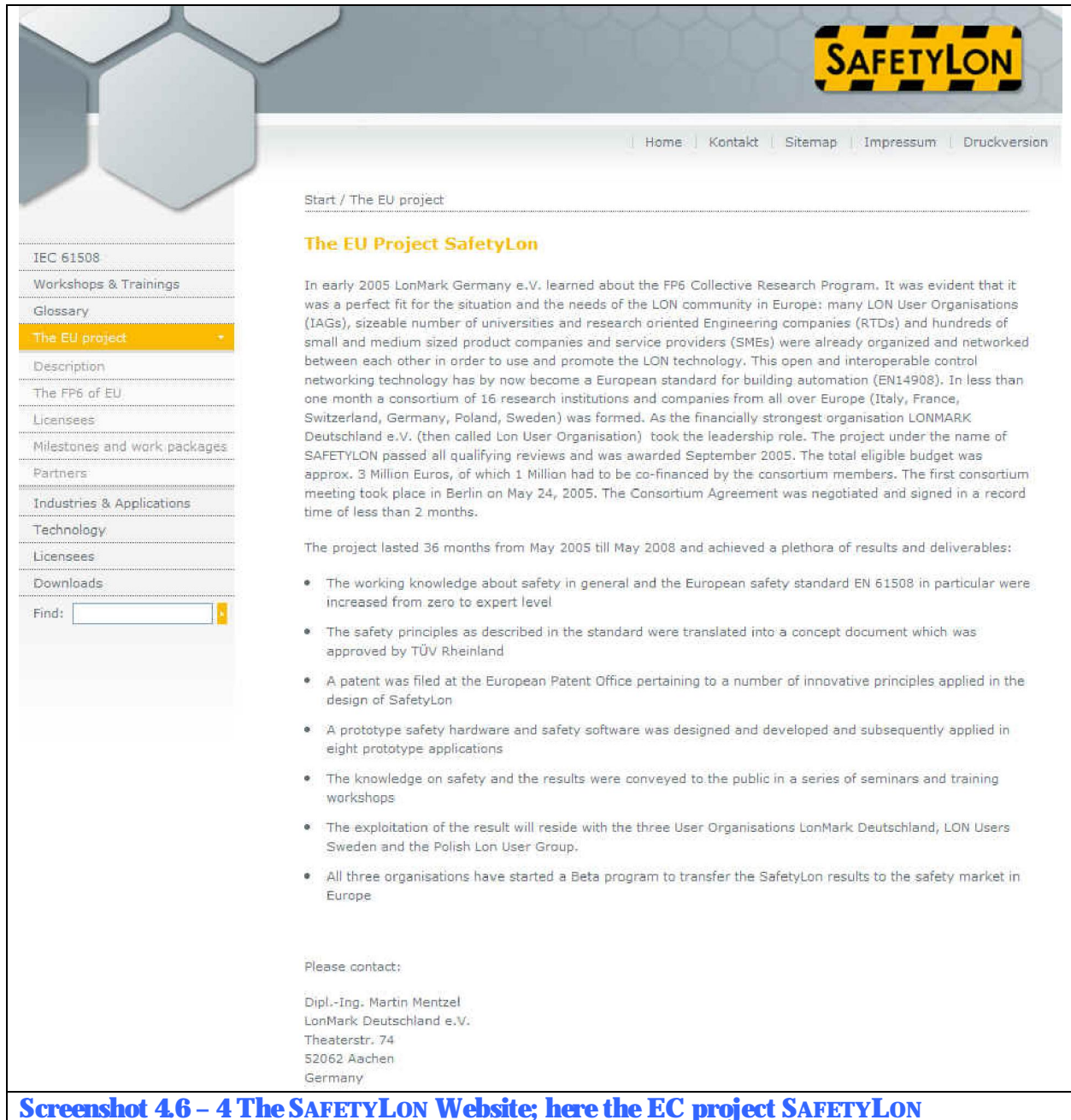
Date:

.....  
(Anders Blom)  
LONMARK Sweden

.....  
(Pawel Kwasnowski)  
Polska Grupa Uzytkownikow  
Technologii LONWORKS

.....  
(Martin Mentzel)  
LONMARK®  
Deutschland e.V.

**Agreement 4.6 – 3 The Joint Ownership Agreement between LMD, LUS and PLUG**



SAFETYLON

Home | Kontakt | Sitemap | Impressum | Druckversion

Start / The EU project

**The EU Project SafetyLon**

In early 2005 LonMark Germany e.V. learned about the FP6 Collective Research Program. It was evident that it was a perfect fit for the situation and the needs of the LON community in Europe: many LON User Organisations (IAGs), sizeable number of universities and research oriented Engineering companies (RTDs) and hundreds of small and medium sized product companies and service providers (SMEs) were already organized and networked between each other in order to use and promote the LON technology. This open and interoperable control networking technology has by now become a European standard for building automation (EN14908). In less than one month a consortium of 16 research institutions and companies from all over Europe (Italy, France, Switzerland, Germany, Poland, Sweden) was formed. As the financially strongest organisation LONMARK Deutschland e.V. (then called Lon User Organisation) took the leadership role. The project under the name of SAFETYLON passed all qualifying reviews and was awarded September 2005. The total eligible budget was approx. 3 Million Euros, of which 1 Million had to be co-financed by the consortium members. The first consortium meeting took place in Berlin on May 24, 2005. The Consortium Agreement was negotiated and signed in a record time of less than 2 months.

The project lasted 36 months from May 2005 till May 2008 and achieved a plethora of results and deliverables:

- The working knowledge about safety in general and the European safety standard EN 61508 in particular were increased from zero to expert level
- The safety principles as described in the standard were translated into a concept document which was approved by TÜV Rheinland
- A patent was filed at the European Patent Office pertaining to a number of innovative principles applied in the design of SafetyLon
- A prototype safety hardware and safety software was designed and developed and subsequently applied in eight prototype applications
- The knowledge on safety and the results were conveyed to the public in a series of seminars and training workshops
- The exploitation of the result will reside with the three User Organisations LonMark Deutschland, LON Users Sweden and the Polish Lon User Group.
- All three organisations have started a Beta program to transfer the SafetyLon results to the safety market in Europe

Please contact:

Dipl.-Ing. Martin Mentzel  
LonMark Deutschland e.V.  
Theaterstr. 74  
52062 Aachen  
Germany

**IEC 61508**  
Workshops & Trainings  
Glossary  
**The EU project**  
Description  
The FP6 of EU  
Licensees  
Milestones and work packages  
Partners  
Industries & Applications  
Technology  
Licensees  
Downloads  
Find:

**Screenshot 46 – 4 The SAFETYLON Website; here the EC project SAFETYLON**

**SAFETYLON**

Look for an Informative SAFETYLON Seminar near You, Coming in the First Half of 2008 to:

- Salzburg, Austria
- Vienna, Austria
- Copenhagen, Denmark
- Helsinki, Finland
- Dusseldorf, Germany
- Hannover, Germany
- Nuremberg, Germany
- Stuttgart, Germany
- Vilnius, Lithuania
- Oslo, Norway
- Krakow, Poland
- Warszawa, Poland
- Wroclaw, Poland
- Stockholm, Sweden
- Bern, Switzerland
- Zurich, Switzerland
- Lviv, Ukraine
- Kiev, Ukraine
- and more.

Bern, Switzerland  
31 October 2007, Stade de Suisse

Zurich, Switzerland  
23 October 2007, Zurich Airport

Visit [www.lonmark.de](http://www.lonmark.de) to see the full schedule.

**Figure 46 – 5 Advertisement in the LONMARK Magazine, International Edition, to promote the series of seminars and training workshops in Europe**




### The 61508 Standard

- Safety requirements of technical systems for the protection of people, the environment and material goods
- Design and Development Guidelines for Hardware and Software
- Functional Safety Management (QA)
- Life Cycle Management
- Risk Graph
- Safety Integrity Levels (SIL)







### SAFETYLON Applications

- Fire Protection and Alarming
- Escape Path Management
- Elevators / Escalators
- Security / Escape doors
- Smoke and Heat Extraction
- Life Saving Systems
- Gas Detection and Alarming
- Traffic / Train Signalling
- Patient Monitoring
- Power Plants
- etc.








### The SAFETYLON Protocol

- Embedded in standard EIA 709 / EN 14908 / LON protocol
- Redundant data transmission
- Similar subframes
- Safe addressing
- Diversitive CRCs
- Replicated protocol services
- Time synchronisation
- Safe Network Variables
- LONMARK data types
- Reaches SIL3
- Residual error probability <math>< 10^{-14}</math>/ hr






Complete and easy to use embedded Development Suite

Hardware and Software Architecture

Entire Test Suite for Hardware and Software

LNS compatible Plug-In and Tool Environment

#### SafetyLON Development Chain



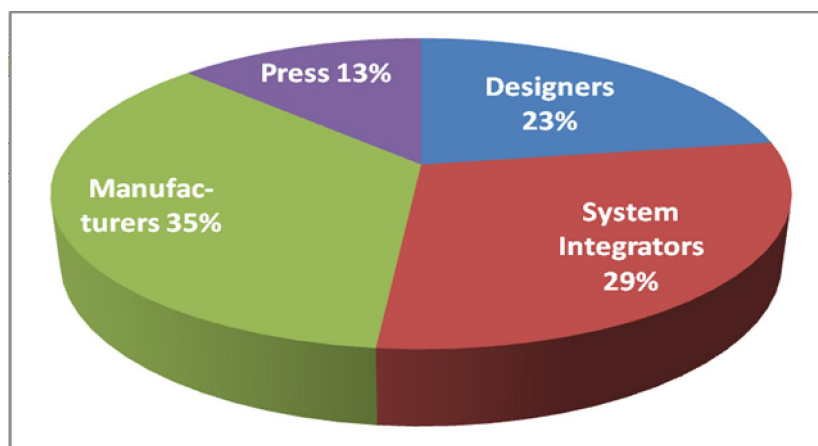
**Pictures 4.6 – 6 to 10 Five Panels on the SAFETYLON booth at Light & Building in Frankfurt**



**Picture 4.6 – 12 Picture of the SAFETYLON booth at Frankfurt Light & Building with large SAFETYLON panels everywhere embedded in the LON community booth of LONMARK Germany (right)**

During the Light & Building 2008 tradeshow in Frankfurt, Germany, from April 6 to April 11, SAFETYLON was presented on the LONMARK Germany community booth. During 6 busy days approx. 50 interested visitors were informed individually and in detail by Martin Mentzel about the technology, the results of the developments and the licensing scheme. On April 7 Martin Mentzel and Jürgen Hertel presented SAFETYLON in a press conference which was attended by approx. 15 journalists of trade magazines. Also, during the tradeshow training tutorials were presented to visitors who showed a deeper interest in SAFETYLON. This was scheduled about twice a day and involved approx. 50% of all visitors.

The visitors can be grouped into designers, system integrators, manufacturers and press. The following chart shows the statistical distribution of these visitor groups:



**Figure 4.6 – 13 Chart of Light & Building visitor groups interested in SAFETYLON**

Developers and system integrators typically expect ready-to-use products available off the shelf which reaffirms our approach of a product oriented technology development like SAFETYLON. At the current state of SAFETYLON the manufacturers are clearly the most interesting target group because as product developers they will be potential OEM licensees. Within this group there are well known and established companies. Some of them are listed here:

| <b>Company</b>                                | <b>Safety Business</b>             |
|---|------------------------------------|
| COOPER Safety                                 | Emergency Lighting Systems         |
| GEA Happel Klimatechnik GmbH                  | Air Control Systems                |
| Panasonic Industrial Europe GmbH              | LEDs for safe applications         |
| Kieback & Peter GmbH & Co. KG                 | Building Automation                |
| Distech Controls                              | Building Automation                |
| Siteco Beleuchtungstechnik GmbH               | Street and Tunnel Lighting Systems |
| Industria Technische Verlichting B.V. (Indal) | Street and Tunnel Lighting Systems |
| TROX  | Air Control Systems                |
| WAGO  | Building and Industrial Automation |

**Figure 4.6 -14 Potential OEM licensees tutored on SAFETYLON during Light & Building**

Manufacturers were mainly interested in details of implementation and in an estimate of time and effort for a full SatyLon product development. Both subject areas could be explained sufficiently and persuasive in most cases. Most of these manufacturers have already been contacted after the tradeshow and will be closely followed up after the project. The other groups, developers, system integrators and the press will be informed on a regular basis.



**Picture 46 - 13 Martin Mentzel and Jürgen Hertel answering questions of journalists during a SAFETYLON Press Conference organized by LONMARK GERMANY in context with Light & Building Frankfurt**

## SafetyLon – LON wird sicher

Das von der LonMark Deutschland initiierte europaweite Forschungsprojekt SafetyLon hatte das Ziel, die LON-Technologie so weiterzuentwickeln, dass die Voraussetzungen für sicherheitsgerichtete Anwendungen (gemäß IEC 61508) in der Prozess- und Gebäudeautomation erfüllt werden.



Das Projekt ist inzwischen so weit gediehen, dass Produkte und Anwendungen entwickelt werden können.

Mit SafetyLon können nicht-sichere und sichere Teilsysteme miteinander kommunizieren und ereignisgesteuert zusammenarbeiten. Auf der Light+Building 2008 stellte die LonMark Deutschland SafetyLon der Öffentlichkeit vor.

### Vier Sicherheitsstufen

Gefährliche Ausfälle oder Fehlfunktionen von industriellen Anlagen und Maschinen, aber auch ein Brand in einem Wohn- oder Bürogebäude, bergen Risiken für Menschen, für die Umwelt oder für Sachwerte. Mit technischen Regelungen und Maßnahmen wird versucht, solche Risiken zu minimieren. Wird die Risikoreduzierung mit programmierbaren elektronischen Systemen durchgeführt, müssen alle verwendeten Komponenten die Anforderungen der globalen Norm IEC 61508 erfüllen. Dieser Standard gilt als anerkannter Stand der Technik. Aus Haftungsgründen muss er von allen Herstellern beachtet werden, die mit ihren Systemen sicherheitstechnische Funktionen unterstützen.

Je nach Risiko werden vier Sicherheitsstufen unterschieden: Von SIL1 (geringes Risiko) bis SIL4 (hohes Risiko). Je höher die Sicherheitsstufe (Safety Integrity

Level SIL), desto höher sind die Anforderungen an Maßnahmen zur Risikoreduzierung.

### SafetyLon-Projekt

Im Rahmen des 6. Europäischen Rahmenprogramms für Collective Research (CR6) hat die LonMark Deutschland zusammen mit 16 europäischen Partnern seit 2005 ein F&E-Projekt mit der Bezeichnung SafetyLon durchgeführt. Zielsetzung dieses Projektes war eine LON-Lösung, die die Voraussetzungen für sicherheitsgerichtete Anwendungen (gemäß IEC 61508) in der Prozess- und Gebäudeautomation erfüllt. So sollten die Voraussetzung geschaffen werden, in der Prozess- und in der Gebäudeautomation sichere und nicht sichere Anwendungen miteinander kombinieren zu können. Mit SafetyLon können nicht-sichere und sichere Teilsysteme miteinander kommunizieren und ereignisgesteuert zusammenarbeiten. Wird z. B. irgendwo im

Gebäude ein beginnender Brand entdeckt, können alle Teilsysteme sofort reagieren: Von der Alarmanlage, Fluchtwegauszeichnung, Aufzugssteuerung, Entrauchung bis hin zur Ver- und Entriegelung von Türen. Entsprechende Anwendungen gibt es in der Industrieautomation: SafetyLon stellt die sichere Erfassung, Verarbeitung und Anzeige von Störmeldungen in Kraftwerken, Raffinerien oder anderen Prozessen sicher. Mit SafetyLon können auch Anlagen errichtet werden, die die Prozess- und Gebäudeautomation integrieren, z. B. in Industriehallen. SafetyLon ermöglicht die Integration sicherheitstechnischer Applikationen in nahezu jeden Automationsprozess.

Mit SafetyLon wird LON nicht nur technisch weiterentwickelt. Die Erweiterung der Anwendungsmöglichkeiten bedeutet auch eine Erweiterung des Marktes für LON. Weitere Informationen unter [www.lonmark.de](http://www.lonmark.de). ◀

**Picture 46 -14 This article in one of approx. 15 articles on SAFETYLON which were published in the German trade press following the Press Conference.**

### **4.6.3. Exploitation and Dissemination after the Project (PK, AB, JH/MM contributions for their respective territories)**

#### **4.6.3.1. PLUG (PK)**

The Polish partners responsible for research, dissemination and exploitation activities have established two infrastructure components for permanent existence after the end of the project. They are:

- SafetyLon Training Laboratory established at AGH-UST and equipped by common efforts and costs borne by University and PLUG within WP 7 of the project (ca. 50 m<sup>2</sup>).
- Equipment of SafetyLon Training Laboratory is widely described in the document D28-D29 (part concerning AGH-UST and PLUG activities for Training – WP7).
- SafetyLon Conformance Testing Laboratory established at AGH-UST within WP3.3 activities for complex testing of safe data communication and safety requirements on the hardware, software and functionality level of SafetyLon nodes (ca. 35 m<sup>2</sup>).
- Equipment of SafetyLon Conformance Testing Laboratory is widely described in the document D12, Part 1, Section 2 SLTS (SafetyLon Test Suite) System Architecture

On the basis of these components Polish partners create the SafetyLon Centre with three directions of activities:

- SafetyLon nodes conformance testing,
- SafetyLon trainings, and
- SafetyLon promotion.

The partners intend to develop and extend the existing conformance testing laboratory for testing of EMC compliance and testing of environmental requirements for safety devices. Also, the partners intend to apply for TÜV accreditation of SafetyLon Conformance Testing Laboratory in Krakow comprising all aspects of testing required for TÜV approval of potential SafetyLon products.

In the next 12 month PLUG plans to present the SafetyLon results at seminars given during tradeshows and other events dedicated to building automation and industrial automation.

Currently planned participations in trade fairs and other events in Poland:

- BUD-GRYF 2009 - Szczecin - 13.03.2009 – 15.03.2009
- TARBUD 2009 – Wrocław – 20.03.2009 – 22.03.2009
- AUTOMATICON 2009 – Warszawa – 31.03.2009 – 3.04.2009

- 
- BUILDING OPEN SYSTEMS 2009 Seminar – Krakow – June 2009
  - BUILDING AUTOMATION 2009 Seminar – Wroclaw – October 2009
  - SECUREX 2010 – Poznan – 26.03.2010 – 29.04.2010

Presentations for industry:

- Presentation for UNICARD company - date to be planned
- Presentation for HYBRYD company – date to be planned
- Presentation for ES-System company – date to be planned

AGH-UST and PLUG plan together to organize four one day trainings on SafetyLon, according to the program developed within WP7. Trainings are planned to be held in January, March, April and May 2009.

Further, AGH-UST plans to implement elements of SafetyLon Training into regular courses for BS and MS students of industrial automation and in postgraduate courses for electrical engineers from industry.

PLUG plans to re-establish a working relationship with three OEM companies, who can become possible partners for implementation of SafetyLon in their products (potential licensees). They are:

- UNICARD company - manufacturer of access control systems
- HYBRYD company – manufacturer of emergency lighting
- ES-System company – manufacturer of emergency lighting

PLUG is also going to prospect for other potential licensees among manufacturers of building automation and industrial control system components.

As mentioned above, AGH-UST and PLUG are going to extend the functionality of its SafetyLon Conformance Testing Laboratory for EMC compliance testing and testing of environmental requirements for safety devices. After this extension will be completed, AGH-UST and PLUG plan to apply for TÜV accreditation for a full SafetyLon Conformance Testing Laboratory. This activity depends on additional funding. Both institutions intend to apply for such funding at structural development funds and other governmental or industrial funding available in Poland.

#### **4.6.3.2 LonMark Germany (LMD)**

LMD has exercised a leading role in the SafetyLon project, as an organization as well as through its RTDs Innotec, who and FH Dortmund, and also through its Management team.

Therefore a very high amount of knowledge and experience has been accumulated in the German group. It is therefore evident that this knowledge must be maintained and commercially exploited, and the network between the contributing individuals must be maintained.

The following activities have already happened after the project:

- (1) Innotec, as a professional consulting firm on safety, is regularly promoting SafetyLon with clients and on trade conferences
- (2) who Ingenieurgesellschaft is actively promoting SafetyLon with one of their clients
- (3) The owners of Innotec and who have established a new company (SafeSquare GmbH) which is now capable of providing the much needed know-how and technology transfer on Safety and , in particular, SafetyLon, to OEM companies Several quotations are in negotiation.
- (4) Two individuals (M. Mentzel, and M. Holz of SafeSquare) have taken a professional training course at TÜV Rheinland and have earned a diploma as a certified Safety Consultant
- (5) LMD finalized the jointly negotiated Jointed Ownership Agreement (JOA) and the Beta SafetyLon License Agreement (SLA) which by now has been ratified and adopted by LUS and PLUG.
- (6) LMD, within its Technical Committee, has established a Task Group SafetyLon, headed by M. Mentzel, the former Technical Project Coordinator. One of his first activities is to continue the work of FH Dortmund regarding the submission of the open safety data definitions to the LonMark International Organisation. The first meeting with the Technical Representative of LonMark has already taken place in Munich.
- (7) The SafetyLon Task Group, although run by LMD, will be open to members of all European LonMark Associations
- (8) Hans-Jörg Schweinzer Loytec) and Thomas Novak (ICT) have taken the initiative to promote SafetyLon within the TC247, TG 4 as a European Safety standard as part of the EN 14908 suite of standards (LON).
- (9) FH Dortmund has announced its interest and willingness to offer its services as a testing institute to test and certify the conformance of SafetyLon products to the specification. It is expected that such a certificate reduced the cost of a TÜV type approval significantly.
- (10) On its last General Assembly meeting of LMD M. Metznel and J. Hertel presented the results of the SafetyLon project to some 35 members. Although a short term return of the co-financing cannot be expected, everybody in the audience was convinced that this LMD “investment” will have a medium and longterm positive return.
- (11) On the same meeting M. Mentzel was elected as one of five board members replacing Jürgen Hertel, who has resigned from the board for reasons of seniority. This will assure that SafetyLon will have a “voice” in the board.
- (12) both SMEs, Intron and Unitro, have announced that they plan to continue their prototype developments and eventually go for a full type approval based on their own safety hardware.

---

LMD as an organization will continue to support the promotion and technical development, , however, on a relatively small budget. In the first quarter 2009 another series of seminars and training workshops is planned. It is therefore of utmost importance that one of the Beta candidates will sign the License Agreement and become a reference site for others to follow.

On our To Do List there are now two points with top priority:

- (1) Rework the Website to remove outdated content so we are ready for launch” once we have the means to pay our provider, and
- (2) Write and publis and present a White Paper which explains the technology in detail but in a “appealing” way so the reader does not shy away from the inherent complexity.


### **4.6.3.3 LON User Sweden (LUS)**

Until today, there is no input in writing from LUS due to a recent severe accident of Anders Blom, president of LUS.

However, the situation in Sweden is, by and large, not very much different from PLUG. The close cooperation between the three organizations, very much on a personal level, too, will assure that one organisation will assist another whenever needed.

## 4.7. Work Package 7: Training (PLUG and IAGs) (PK, AB, JH/MM contributions for their respective territories)

In period II the RTDs gave two training workshops for the SMEs. The first, held on January 25, 2007 was primarily a tutorial of the RTDs about their accomplishments. The objective of the workshop was to prepare the SMEs for the tasks ahead of them, and give them the necessary information and explanations for the many questions they had. The following very well prepared event took place on May 3 and 4, 2007 at the ICT of TUW. Following is the Agenda which was prepared by LMD and AGH-UST.

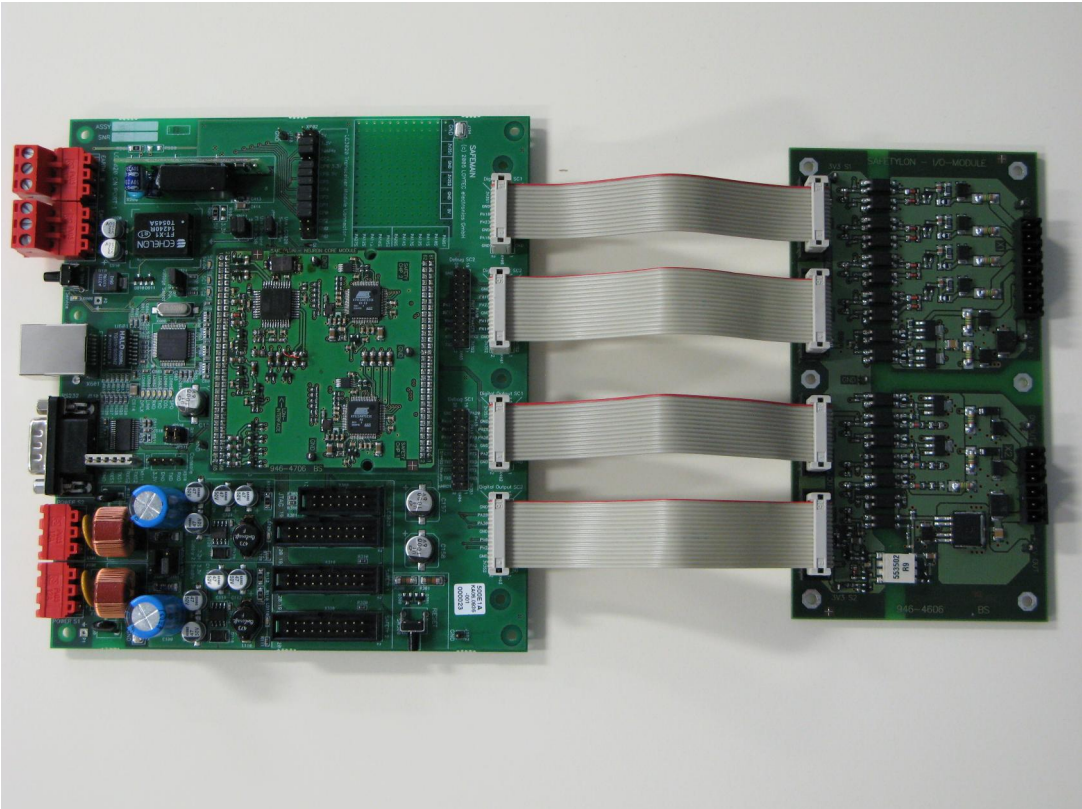
|   |   |   |              |
|---|---|---|--------------|
|  |   | <h1>SME Workshop 2007</h1> <h2>Agenda</h2> <p><b>03. - 04. May, 2007</b><br/> <b>09:00 until 18:00</b><br/> <b>Location: ICT Vienna, Seminar Room, 4<sup>th</sup> floor</b></p> |              |
| <b>Coordinator:</b>   | Jürgen Hertel   | <b>Type of meeting:</b>   | SME Workshop |
| <b>Content planning:</b>  | Pawel Kwasnowski  | <b>Note taker:</b>  | JH /PK       |
| <b>Attendees:</b>   | All SMEs,<br>attendees from RTDs are welcome. However, they have to bring their own hardware and must participate in the hands-on work  |   |              |
| <b>How to prepare ?</b>   | <ul style="list-style-type: none"> <li>• Understand the current state of project results available in Projectplace</li> <li>• Be familiar with KEIL MDK-ARM development environment</li> <li>• Be familiar with ULINK2-JTAG interface application</li> <li>• Be familiar with an LNS Integration tool (LonMaker or NL220)</li> </ul>  |   |              |
| <b>What to bring ?</b>  | <ul style="list-style-type: none"> <li>• Laptop with preinstalled and tested:             <ul style="list-style-type: none"> <li>○ KEIL MDK-ARM development environment</li> <li>○ LNS Integration tool</li> </ul> </li> <li>• ULINK2-JTAG interface</li> <li>• LON Interface for Laptop (USB stick)</li> <li>• External input / output components (switches, contacts, PS for output relays)</li> <li>• Spare cables, connectors, electrical tools</li> <li>• USB hub</li> </ul> |   |              |
| ----- <b>Agenda Topics</b> -----  |   |   |              |
| <b>Topics</b>   | <b>Items covered</b>  | <b>who</b>  |              |
| <b>Begin: 09:00</b>   | <b>DAY 1</b>  |   |              |
| 1. Overview project status  | This module provides you with an overview on the entire RTD development work of Work packages 1 to 4, the latest project plan and   | MM  |              |

|  |   |                                      |
|--|---|--------------------------------------|
| incl Q & As (1 hr)   | your role in it, the TÜV certification work, and the work ahead of us to complete SME development in WP5  |                                      |
| 2. Overview SAFETYLON Hardware (1 hr Minutes)  | <ul style="list-style-type: none"> <li>• safe main board</li> <li>• safe LC3020 core module</li> <li>• safe FT3120 module</li> <li>• safe I/O module</li> <li>• external connections: <ul style="list-style-type: none"> <li>○ Power supply</li> <li>○ JTAG interface</li> <li>○ application inputs - sensors</li> <li>○ application outputs - actuators</li> </ul> </li> </ul>   | DL /DT                               |
| 3. Bringing up everybody's hardware up incl. I/O (2 hrs)   | <ul style="list-style-type: none"> <li>• Check list: do you have all necessary hardware components and connections</li> <li>• Check list: do you have all necessary software tools installed</li> </ul>   | TT<br>Assistant<br>: PR              |
| <b>LUNCH</b>   |   |                                      |
| 4. Overview SAFETYLON Software (1 hr)  | <ul style="list-style-type: none"> <li>• General Software Overview and Structure</li> <li>• Interface Software: Shortstack, ORION stack <ul style="list-style-type: none"> <li>○ How to get them working ?</li> <li>○ How to configure an XIF file ?</li> <li>○ SNVT representation in a User Application Layer</li> </ul> </li> <li>• Atmel embedded software – Safety Operating System (SOS) <ul style="list-style-type: none"> <li>○ Overview and Structure</li> <li>○ Functionality</li> </ul> </li> <li>• How to get it working ? <ul style="list-style-type: none"> <li>○ loading SOS chip 1</li> <li>○ loading SOS chip 2</li> <li>○ testing that it works properly</li> </ul> </li> <li>• User Application Interface (API)</li> </ul> | TN                                   |
| 5. Setting up the SME development environment incl. testing (3 hrs)  | In this module the SMEs practice how to set up their own hardware and development environment so they can successfully participate in day 2.  | TT<br>Assistant<br>: HQ              |
| <b>JOINT DINNER</b>  |   |                                      |
| <b>Begin: 09:00</b>  |   |                                      |
| <b>DAY 2</b>   |   |                                      |
| 6. Sample application A from specification to source to running application: presentation and demo incl. Q & As (1 hr) | In this module NN (Loytec) demonstrates how to implement a safe application software on the reference hardware with a LC3020 core module  | TT/TN                                |
| 7. Sample application B: from specification to source to running application: presentation and demo incl. Q&As (1 hr)  | In this module HQ (who) demonstrates how to implement a safe application software on the reference hardware with a Neuron FT3120 core module  | HQ (with<br>TT/TN<br>as a<br>backup) |
| 8. Integration tools and procedures to install safe nodes: Presentation and demo, Q&A (1 hr)                           | <ul style="list-style-type: none"> <li>• Conversion tools (if any)</li> <li>• Integration methodology</li> <li>• Integration steps</li> <li>• Integration example - transfer of safety input signal from Node 1 to safety output signal fo Node 2</li> </ul>  | MM/MH<br>/HQ                         |

| <b>LUNCH</b>   |  |                      |
|--|--|----------------------|
| 9. SME's design, code, compile, load, run and test their own small sample applications on the reference hardware (3 hrs); the application program must be prepared and tested prior to the workshop on a non-safe node | <ul style="list-style-type: none"> <li>• Node Input Read -The Same Node Output Write with Input Change notification by network</li> <li>• Node Input Read and Send Change by network</li> <li>• Read SNVT and set Node Output</li> <li>• Safe Network Integration               <ul style="list-style-type: none"> <li>○ Standard Network Integration</li> <li>○ Assignment of safe addresses</li> <li>○ Safety Functionality Integration</li> </ul> </li> </ul> | each SME by himself  |
| 10. SME's commission a two node safe sensor / actuator network with at least one safe binding (1hr)  | In this module a team of two SMEs create their first two node SAFETYLON network making use of the nodes they have developed in module 9.   | two SME's team up    |
| 11. Filling out the Feedback form  | Your feedback is essential in order to document how successful the workshop was for you, and what needs to be improved for a professional training class to be developed in WP7  | All SME participants |
| 12. Summary and next steps   |  | PK and MM            |
| 17:30  | <b>End of Workshop</b>   |                      |
| List of name abbreviations:  |  |                      |
| JH... Jürgen Hertel (LMD)  |  |                      |
| PK...Pawel Kwasnowski (AGH-UST)  |  |                      |
| MM...Martin Mentzel (Innotec, FH Dortmund)   |  |                      |
| DL...Dietmar Loy (Loytec)  |  |                      |
| DT...Detlef Thon (who Ingenieurgesellschaft)   |  |                      |
| TT...Thomas Tamandl (ICT /TUV)   |  |                      |
| TN...Thomas Novak (ICT/ TUV)   |  |                      |
| HQ...Hartmut Quast (who Ingenieurgesellschaft)   |  |                      |
| MH...Michael Holz (FH Dortmund)  |  |                      |
| PR...Philip Rickli (IBT)   |  |                      |
| <b>Table 4.7 – 1 SME Workshop 2008, May 3 -4, 1007</b>   |  |                      |



**Picture 4.7 - 2 SME class doing exercises (H. Quast and D. Thon of who coaching)**



**Picture 4.7. - 3 The SME prototype hardware**



**Picture 4.7 - 4 Mikos and Grzegorz of AGH-UST picking up their new kits.**

This workshop was a major milestone of achievement as well as a motivational “kick” that everybody had been waiting for.

The development kit is also the basis of the training kit for external SAFETYLON trainees which will then be packaged in a box so that it can be quickly assembled and used. AGH-UST is currently putting together the specifications for a portable kit.

Regarding periods III training events here are the planned events which the IAG panel has decided on as a minimum, depending on the remaining time and funding:

- (1) After 2 SME training workshops in period II at least another two day training workshops are required : one in 12/2007 in conjunction with the next Consortium Meeting; a second one in 03/2008 on which the SME results shall be presented, with the objective to eliminate errors and finetune the applications
- (2) Preparation of training kit “in the box” by AGH-UST. Contrary to the original plan the number of kits will be significantly higher, since max. two students must share one kit. The current plan is to build 25 kits: 12 kits for LMD, 6 kits for LMS and 6 kits for PLUG, 1 spare
- (3) Preparation of course material based on the material used for the SME training; leading RTD is AGH-UST
- (4) LMD will offer 4 training workshops (2 in Germany: 2 LMD internal, 2 external); LMS and PLUG each will offer 1 training workshop (internal and external combined); TEMA shall be involved in recruiting students
- (5) LMD will offer one special training class for the trainer(s) of currently contracted LMD training institutions and interested trainers coming from LMD members; LMS and PLUG may do the same, time permitting

(6) one in-house training for the pilot or alpha customer by LMD, LMS and PLUG each; depending on the success in recruiting such pilot customer

#### Activities in Period III

#### 4.7.1. PLUG activities in WP 7

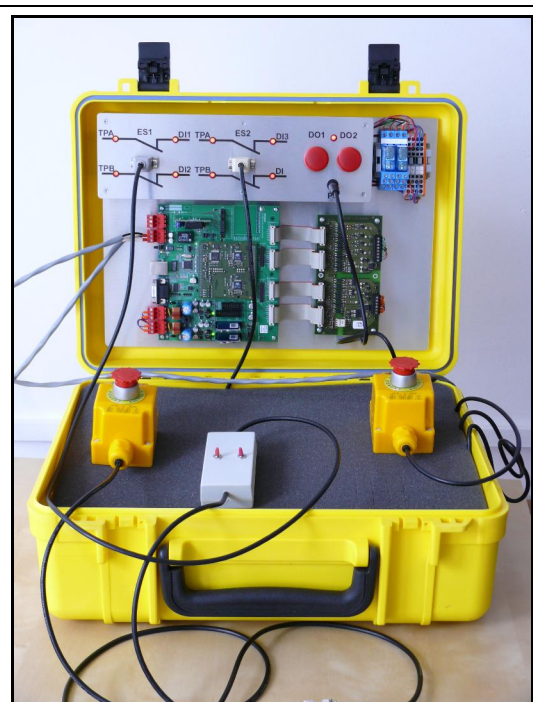
PLUG was involved in planning and development of training course program and training handbook. Due to limited resources of AGH-UST, whose all resources were exhausted by strongly extended work of complex black box testing of the SAFETYLON nodes, almost the whole work required for WP 7, which means: development of training program, contents of training courses, preparation and editing of training handbook (in English and in Polish and development and assembly of six portable training stands (training kits), was shifted to PLUG. PLUG applied the art. 9 of the contract and used for this work contribution from members of association, in this case ZDANIA.

#### 4.7.2. Training environment

AGH-UST and PLUG settled the training environment located at AGH-UST campus, building B5, room 210. This is permanently arranged training laboratory room dedicated for trainings planned within the project and also intended to be run after the end of the project.. This laboratory will be used after the project end as a SAFETYLON Training Centre. Together with environment for SAFETYLON conformance testing developed within the WP 3.3. Both laboratories (training laboratory and conformance testing laboratory) will be the starting point of SAFETYLON Centre run by AGH-UST and PLUG after the project will be finished.



**Picture 4.7 - 5 SAFETYLON Training Lab at AGH-UST**



**Picture 4.7 - 6 SAFETYLON Training Kit**



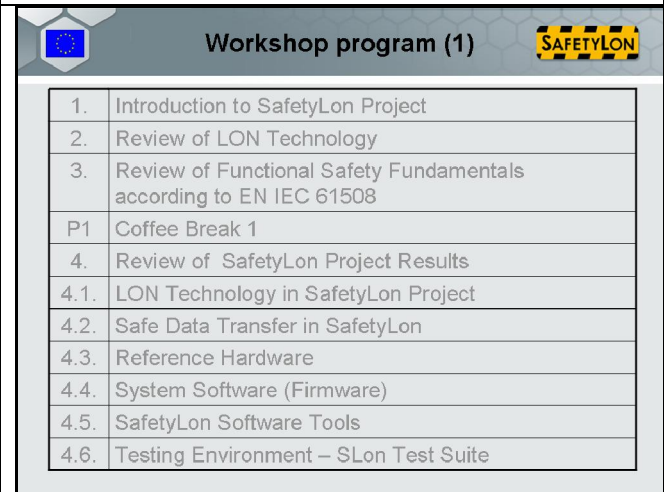
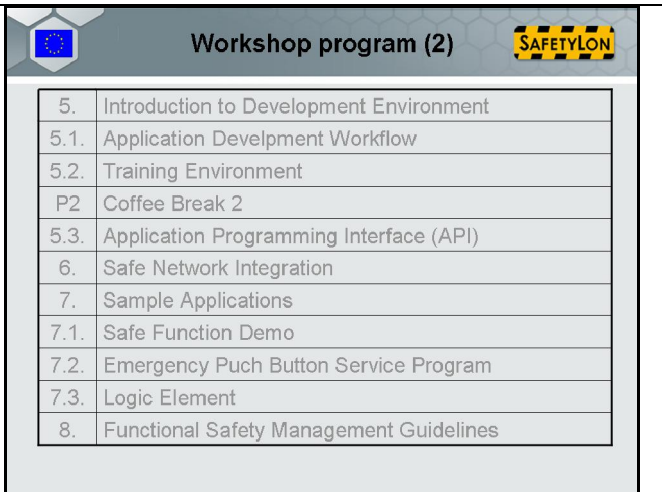
A detailed description of the Training Kit is documented in Deliverable D27.

### 4.7.3. Training program and training handbooks

Training program was developed on the basis of many IAG meetings and discussions and current status of the project. PLUG prepared the Training Program and Training Handbook in English and in Polish.

#### 4.7.3.1. Training program and training handbook in English

The program slides are included below. Contents of all training presentations are enclosed in a separate file: SLTH-ENG.zip. Training presentations were edited and printed as a SAFETYLON Training Workshop Handbook.

|   |  |                                   |    |                          |    |  |    |                |    |                                     |      |                                     |      |                                 |      |                    |      |                            |      |                          |      |                                       |   |    |   |      |                                  |      |                      |    |                |      |   |    |                          |    |                     |      |                    |      |                                       |      |               |    |   |
|---|--|-----------------------------------|----|--------------------------|----|--|----|----------------|----|-------------------------------------|------|-------------------------------------|------|---------------------------------|------|--------------------|------|----------------------------|------|--------------------------|------|---------------------------------------|---|----|---|------|----------------------------------|------|----------------------|----|----------------|------|---|----|--------------------------|----|---------------------|------|--------------------|------|---------------------------------------|------|---------------|----|---|
|  <p>WELCOME<br/>Training Workshop</p> <p><b>SafetyLon Technology</b><br/>in Functional Safety Related Systems<br/><b>Workshop Program</b><br/>Module 0</p> <p>LONMARK DEUTSCHLAND LONMARK SVENSK POLISH LON USERS GROUP AGH</p>   |  <p>WELCOME<br/>Warsztaty szkoleniowe</p> <p><b>Technologia SafetyLon</b><br/>w systemach związanych z bezpieczeństwem<br/>funkcjonalnym<br/><b>Program warsztatów</b><br/>Moduł 0</p> <p>LONMARK DEUTSCHLAND LONMARK SVENSK POLISH LON USERS GROUP AGH</p> |                                   |    |                          |    |  |    |                |    |                                     |      |                                     |      |                                 |      |                    |      |                            |      |                          |      |                                       |   |    |   |      |                                  |      |                      |    |                |      |   |    |                          |    |                     |      |                    |      |                                       |      |               |    |   |
|  <p>Workshop program (1)</p> <table border="1"> <tbody> <tr><td>1.</td><td>Introduction to SafetyLon Project</td></tr> <tr><td>2.</td><td>Review of LON Technology</td></tr> <tr><td>3.</td><td>Review of Functional Safety Fundamentals according to EN IEC 61508</td></tr> <tr><td>P1</td><td>Coffee Break 1</td></tr> <tr><td>4.</td><td>Review of SafetyLon Project Results</td></tr> <tr><td>4.1.</td><td>LON Technology in SafetyLon Project</td></tr> <tr><td>4.2.</td><td>Safe Data Transfer in SafetyLon</td></tr> <tr><td>4.3.</td><td>Reference Hardware</td></tr> <tr><td>4.4.</td><td>System Software (Firmware)</td></tr> <tr><td>4.5.</td><td>SafetyLon Software Tools</td></tr> <tr><td>4.6.</td><td>Testing Environment – SLon Test Suite</td></tr> </tbody> </table> | 1.   | Introduction to SafetyLon Project | 2. | Review of LON Technology | 3. | Review of Functional Safety Fundamentals according to EN IEC 61508 | P1 | Coffee Break 1 | 4. | Review of SafetyLon Project Results | 4.1. | LON Technology in SafetyLon Project | 4.2. | Safe Data Transfer in SafetyLon | 4.3. | Reference Hardware | 4.4. | System Software (Firmware) | 4.5. | SafetyLon Software Tools | 4.6. | Testing Environment – SLon Test Suite |  <p>Workshop program (2)</p> <table border="1"> <tbody> <tr><td>5.</td><td>Introduction to Development Environment</td></tr> <tr><td>5.1.</td><td>Application Development Workflow</td></tr> <tr><td>5.2.</td><td>Training Environment</td></tr> <tr><td>P2</td><td>Coffee Break 2</td></tr> <tr><td>5.3.</td><td>Application Programming Interface (API)</td></tr> <tr><td>6.</td><td>Safe Network Integration</td></tr> <tr><td>7.</td><td>Sample Applications</td></tr> <tr><td>7.1.</td><td>Safe Function Demo</td></tr> <tr><td>7.2.</td><td>Emergency Push Button Service Program</td></tr> <tr><td>7.3.</td><td>Logic Element</td></tr> <tr><td>8.</td><td>Functional Safety Management Guidelines</td></tr> </tbody> </table> | 5. | Introduction to Development Environment | 5.1. | Application Development Workflow | 5.2. | Training Environment | P2 | Coffee Break 2 | 5.3. | Application Programming Interface (API) | 6. | Safe Network Integration | 7. | Sample Applications | 7.1. | Safe Function Demo | 7.2. | Emergency Push Button Service Program | 7.3. | Logic Element | 8. | Functional Safety Management Guidelines |
| 1.  | Introduction to SafetyLon Project  |                                   |    |                          |    |  |    |                |    |                                     |      |                                     |      |                                 |      |                    |      |                            |      |                          |      |                                       |   |    |   |      |                                  |      |                      |    |                |      |   |    |                          |    |                     |      |                    |      |                                       |      |               |    |   |
| 2.  | Review of LON Technology   |                                   |    |                          |    |  |    |                |    |                                     |      |                                     |      |                                 |      |                    |      |                            |      |                          |      |                                       |   |    |   |      |                                  |      |                      |    |                |      |   |    |                          |    |                     |      |                    |      |                                       |      |               |    |   |
| 3.  | Review of Functional Safety Fundamentals according to EN IEC 61508   |                                   |    |                          |    |  |    |                |    |                                     |      |                                     |      |                                 |      |                    |      |                            |      |                          |      |                                       |   |    |   |      |                                  |      |                      |    |                |      |   |    |                          |    |                     |      |                    |      |                                       |      |               |    |   |
| P1  | Coffee Break 1   |                                   |    |                          |    |  |    |                |    |                                     |      |                                     |      |                                 |      |                    |      |                            |      |                          |      |                                       |   |    |   |      |                                  |      |                      |    |                |      |   |    |                          |    |                     |      |                    |      |                                       |      |               |    |   |
| 4.  | Review of SafetyLon Project Results  |                                   |    |                          |    |  |    |                |    |                                     |      |                                     |      |                                 |      |                    |      |                            |      |                          |      |                                       |   |    |   |      |                                  |      |                      |    |                |      |   |    |                          |    |                     |      |                    |      |                                       |      |               |    |   |
| 4.1.  | LON Technology in SafetyLon Project  |                                   |    |                          |    |  |    |                |    |                                     |      |                                     |      |                                 |      |                    |      |                            |      |                          |      |                                       |   |    |   |      |                                  |      |                      |    |                |      |   |    |                          |    |                     |      |                    |      |                                       |      |               |    |   |
| 4.2.  | Safe Data Transfer in SafetyLon  |                                   |    |                          |    |  |    |                |    |                                     |      |                                     |      |                                 |      |                    |      |                            |      |                          |      |                                       |   |    |   |      |                                  |      |                      |    |                |      |   |    |                          |    |                     |      |                    |      |                                       |      |               |    |   |
| 4.3.  | Reference Hardware   |                                   |    |                          |    |  |    |                |    |                                     |      |                                     |      |                                 |      |                    |      |                            |      |                          |      |                                       |   |    |   |      |                                  |      |                      |    |                |      |   |    |                          |    |                     |      |                    |      |                                       |      |               |    |   |
| 4.4.  | System Software (Firmware)   |                                   |    |                          |    |  |    |                |    |                                     |      |                                     |      |                                 |      |                    |      |                            |      |                          |      |                                       |   |    |   |      |                                  |      |                      |    |                |      |   |    |                          |    |                     |      |                    |      |                                       |      |               |    |   |
| 4.5.  | SafetyLon Software Tools   |                                   |    |                          |    |  |    |                |    |                                     |      |                                     |      |                                 |      |                    |      |                            |      |                          |      |                                       |   |    |   |      |                                  |      |                      |    |                |      |   |    |                          |    |                     |      |                    |      |                                       |      |               |    |   |
| 4.6.  | Testing Environment – SLon Test Suite  |                                   |    |                          |    |  |    |                |    |                                     |      |                                     |      |                                 |      |                    |      |                            |      |                          |      |                                       |   |    |   |      |                                  |      |                      |    |                |      |   |    |                          |    |                     |      |                    |      |                                       |      |               |    |   |
| 5.  | Introduction to Development Environment  |                                   |    |                          |    |  |    |                |    |                                     |      |                                     |      |                                 |      |                    |      |                            |      |                          |      |                                       |   |    |   |      |                                  |      |                      |    |                |      |   |    |                          |    |                     |      |                    |      |                                       |      |               |    |   |
| 5.1.  | Application Development Workflow   |                                   |    |                          |    |  |    |                |    |                                     |      |                                     |      |                                 |      |                    |      |                            |      |                          |      |                                       |   |    |   |      |                                  |      |                      |    |                |      |   |    |                          |    |                     |      |                    |      |                                       |      |               |    |   |
| 5.2.  | Training Environment   |                                   |    |                          |    |  |    |                |    |                                     |      |                                     |      |                                 |      |                    |      |                            |      |                          |      |                                       |   |    |   |      |                                  |      |                      |    |                |      |   |    |                          |    |                     |      |                    |      |                                       |      |               |    |   |
| P2  | Coffee Break 2   |                                   |    |                          |    |  |    |                |    |                                     |      |                                     |      |                                 |      |                    |      |                            |      |                          |      |                                       |   |    |   |      |                                  |      |                      |    |                |      |   |    |                          |    |                     |      |                    |      |                                       |      |               |    |   |
| 5.3.  | Application Programming Interface (API)  |                                   |    |                          |    |  |    |                |    |                                     |      |                                     |      |                                 |      |                    |      |                            |      |                          |      |                                       |   |    |   |      |                                  |      |                      |    |                |      |   |    |                          |    |                     |      |                    |      |                                       |      |               |    |   |
| 6.  | Safe Network Integration   |                                   |    |                          |    |  |    |                |    |                                     |      |                                     |      |                                 |      |                    |      |                            |      |                          |      |                                       |   |    |   |      |                                  |      |                      |    |                |      |   |    |                          |    |                     |      |                    |      |                                       |      |               |    |   |
| 7.  | Sample Applications  |                                   |    |                          |    |  |    |                |    |                                     |      |                                     |      |                                 |      |                    |      |                            |      |                          |      |                                       |   |    |   |      |                                  |      |                      |    |                |      |   |    |                          |    |                     |      |                    |      |                                       |      |               |    |   |
| 7.1.  | Safe Function Demo   |                                   |    |                          |    |  |    |                |    |                                     |      |                                     |      |                                 |      |                    |      |                            |      |                          |      |                                       |   |    |   |      |                                  |      |                      |    |                |      |   |    |                          |    |                     |      |                    |      |                                       |      |               |    |   |
| 7.2.  | Emergency Push Button Service Program  |                                   |    |                          |    |  |    |                |    |                                     |      |                                     |      |                                 |      |                    |      |                            |      |                          |      |                                       |   |    |   |      |                                  |      |                      |    |                |      |   |    |                          |    |                     |      |                    |      |                                       |      |               |    |   |
| 7.3.  | Logic Element  |                                   |    |                          |    |  |    |                |    |                                     |      |                                     |      |                                 |      |                    |      |                            |      |                          |      |                                       |   |    |   |      |                                  |      |                      |    |                |      |   |    |                          |    |                     |      |                    |      |                                       |      |               |    |   |
| 8.  | Functional Safety Management Guidelines  |                                   |    |                          |    |  |    |                |    |                                     |      |                                     |      |                                 |      |                    |      |                            |      |                          |      |                                       |   |    |   |      |                                  |      |                      |    |                |      |   |    |                          |    |                     |      |                    |      |                                       |      |               |    |   |
| <p>Slide <b>47 - 7 SAFETYLON Training Workshop (English and Polish, top)</b></p>  | <p>Slide <b>47 - 8 SAFETYLON Training Workshop program (English, bottom)</b></p>   |                                   |    |                          |    |  |    |                |    |                                     |      |                                     |      |                                 |      |                    |      |                            |      |                          |      |                                       |   |    |   |      |                                  |      |                      |    |                |      |   |    |                          |    |                     |      |                    |      |                                       |      |               |    |   |



**Picture 47 -9 SAFETYLON Training Workshop Handbook in English**



**Picture 47 - 10 SAFETYLON Training Workshop Handbook in Polish**

#### **4.7.3.2. Training program and training handbook in Polish**

Contents of all training presentations are enclosed in a separate file: SLTH-PL. Training presentations were edited and printed as a SAFETYLON Training Workshop Handbook.

#### **4.7.4. Trainings organized by PLUG**

Polish LonUser Group PLUG organized 6 training workshops. Due to not too many members of PLUG, courses were dedicated to all professionals interested in the safe communication and safe control systems in industry.

Altogether there were organized 6 events. Three of them were associated with industrial fairs and the next three took place at the technical universities.

The table below presents dates, locations and number of participants of the training workshops organized by Polish LonUsers Group in Poland.

| Pos. | Date       | City     | Institution/Event   | Number of participants |
|------|------------|----------|---|------------------------|
| 1.   | 2008-03-08 | Wroclaw  | TARBUD 2008 – Building Industry Fair  | 8                      |
| 2.   | 2008-04-02 | Warszawa | AUTOMATICON 2008 – The biggest exhibition in Poland dedicated to industrial control systems | 18                     |
| 3.   | 2008-04-03 | Warszawa | AUTOMATICON 2008 – The biggest exhibition in Poland dedicated to industrial control systems | 10                     |
| 4.   | 2008-04-18 | Wroclaw  | Wroclaw Technical University (Politechnika Wroclawska)                                      | 9                      |
| 5.   | 2008-05-20 | Krakow   | AGH-UST   | 7                      |
| 6.   | 2008-05-21 | Krakow   | AGH-UST   | 10                     |
|      | Total      |          |   | 62                     |

**Table 4.7 - 11 List of training workshops organized by PLUG**

| SAFETYLON |                            | Lista obecności - Szkolenie SAFETYLON<br>Targi budownictwa TARBUD 2008<br>Wroclaw 8.03.2008 |                         |             |   |                      |
|-----------|----------------------------|---|-------------------------|-------------|---|----------------------|
| Poz.      | Nazwisko i imię            | Instytucja/Adres  | Adres do korespondencji | Telefon     | e-mail                                  | Podpis               |
| 1.        | DARIUSZ BUKOT              | ZURBIEK „BUDER”<br>JELENIA GÓRA   |                         | 601 789 296 |   | BukotD               |
| 2.        | Radosław Mioduski          | Kompakt<br>Wroclaw  | Wroclaw                 | 602 058 876 | radolmioduski@wp.pl                     | Mioduski             |
| 3.        | Roman Grogan               | PWR   |                         |             | grogan@pwr.wroc.pl                      | Roman                |
| 4.        | Tafarek Andrzej            | PWV   | Wroclaw                 | 370 38 371  | andrzei.tafarek@pwr.wroc.pl             | Tafarek              |
| 5.        | Rogalski Janusz            | PWV   | Wroclaw                 | 507 29 5635 | janusz.rogalski@pwr.wroc.pl             | Rogalski             |
| 6.        | Grodzinski Marcin          | STUDENT PWR   | Wroclaw                 |             | marcin.grodzinski@pwr.wroc.pl           | Grodzinski           |
| 7.        | Kubas Karol<br>Kucielowski | PDU<br>HALLIS BIAVO   | Wroclaw<br>Wroclaw      | 370 38 211  | karol.kubas@pwr.wroc.pl<br>hallis@wp.pl | Kubas<br>Kucielowski |
|           |                            |   |                         |             |   |                      |
|           |                            |   |                         |             |   |                      |
|           |                            |   |                         |             |   |                      |
|           |                            |   |                         |             |   |                      |
|           |                            |   |                         |             |   |                      |

**Figure 4.7 - 12 List of participants at SAFETYLON Training Workshop at TARBUD 2008 in Wroclaw, held on March 8, 2008**

Note: the complete list of participants for all events is available in Deliverable D 28&29 of PLUG.



**Figure 4.7 - 13 Training Workshop at AGH-UST, May 20, 2008**

Note: the complete series of class room pictures for all events is available in Deliverable D 28&29 for PLUG.

#### **4.7.5. LMD Activities in WP 7**

Regarding dissemination a series of seminars and training workshop were held in all three regions. Despite of an enormous recruiting effort address material by the IAG central offices, in particular by TEMA, the agency of LONMARK Germany, the number of participants per seminar was below our expectations and below the numbers stated in the DoW V2.0. relatively speaking, Poland scored the best of all IAGs. One reason, of course, was that in 2006 and 2007 we had already informed the LONMARK members and “insiders” about SAFETYLON on various occasions like Annual General Assemblies, Task Group meetings and tradeshows. Another reason which pertains to external prospects may be, that LON is still an unknown to many people in the safety community. We expect that this is going to change in the near future.

**Anmeldung**

Melden Sie sich einfach online unter:  
[www.lonmark.de/terminevents/Safetylon08.asp](http://www.lonmark.de/terminevents/Safetylon08.asp)

Oder schicken Sie bitte folgendes Formular per Fax an:  
 +49 241 88970-42

Zum Seminar „S4emL0vi – LON goes Safe“ am

- 23. April 2008 in Nürnberg
- 24. April 2008 in Stuttgart
- 06. Mai 2008 in Frankfurt
- 08. Mai 2008 in Düsseldorf
- 27. Mai 2008 in Wien
- 28. Mai 2008 in Salzburg

Zu den Training Workshops am

- 13. Mai 2008 in Frankfurt für LMD Mitglieder
- 14. Mai 2008 in Frankfurt
- 15. Mai 2008 in Dortmund

melde ich mich verbindlich an:

Name: \_\_\_\_\_  
 Firma: \_\_\_\_\_  
 Strasse: \_\_\_\_\_  
 PLZ/Ort: \_\_\_\_\_  
 E-Mail: \_\_\_\_\_  
 Tel: \_\_\_\_\_  
 Fax: \_\_\_\_\_

Die Teilnahme an den Seminaren ist kostenlos.  
 Für das leibliche Wohl ist gesorgt.

Ort, Datum Unterschrift

Weitere Informationen:  
 LonMark Deutschland e.V. Tel. + 49-241-88970-36  
 Theaterstraße 74 Fax + 49-241-88970-42  
 52062 Aachen office@lonmark.de, www.lonmark.de

**LON<sup>®</sup> goes safe**

Seminare zum Thema:  
 Sicherheitsgerichtete Applikationen  
 für Industrie und Gebäude nach IEC 61508

**Wir freuen uns auf Sie!**

Sehr geehrte Damen und Herren,

Die LonMark Deutschland veranstaltet in der ersten Jahreshälfte 2008 Seminare mit dem Thema „S4emL0vi – LON goes Safe“.

Die genannten Veranstaltungen wenden sich an alle, die sich über moderne Sicherheitstechnik nach IEC 61508 informieren wollen. Zwei Mitglieder des S4emL0vi Konsortiums werden Ihnen einen Einblick in den Sicherheitsstandard IEC61508 geben und dessen Umsetzung in das S4emL0vi Konzept vorstellen. Sie werden erklären, wie mit S4emL0vi sichere Hard- und Softwaremodule spezifiziert, entwickelt, getestet und angewendet werden und wie sich die neue Technologie in sicherheitsgerichtete Produkte und Systeme umsetzen lässt.

Die Veranstaltungstermine sind:

- Nürnberg 23.04.2008
- Stuttgart 24.04.2008
- Frankfurt 06.05.2008
- Düsseldorf 08.05.2008
- Wien 27.05.2008
- Salzburg 28.05.2008

Training Workshops:

- Frankfurt 13. Mai 2008 (für LMD Mitglieder)
- Frankfurt 14. Mai 2008
- Dortmund 15. Mai 2008

**Agenda**

9:30 Uhr Willkommen  
 Sicherheitsapplikation in der Gebäudeautomation und in industriellen Anwendungen  
 Die Norm IEC 61508 und ihre Anwendung in vernetzten Sicherheitssystemen

10:45 Uhr Diskussion und Kaffeepause  
 Fehlermöglichkeiten in der seriellen Kommunikation und deren Behebung/Reduktion  
 Das S4emL0vi EU Projekt – von der Idee bis zur Umsetzung

12:30 Uhr bis 1:30 Uhr Diskussion und Mittagessen

Prinzipien der Entwicklung einer sicheren Hardware und deren Umsetzung auf LON (SIL 3)

Prinzipien der Entwicklung einer sicheren Software und deren Implementierung auf der S4emL0vi Hardware

1:45 Uhr Diskussion und Kaffeepause  
 Prinzipien der Inbetriebnahme eines sicheren S4emL0vi-Netzwerks unter Verwendung von Standard-IIS Tools und speziellen Plug-Ins  
 Entwicklung von Prototyp-Anwendungen aus dem Bereich der Gebäudeautomation  
 Testumgebung für S4emL0vi-Produkte und Prototyp eines Konformitätsassess  
 Das S4emL0vi Beta-Programm

16:30 Uhr Get Together

Organisation:  
 Stefan Graber • TEMA Technology Marketing AG  
 Theaterstr. 74 • 52062 Aachen • Germany  
 Tel.: +49-241-88970-51 • Fax: +49-241-88970-42  
 E-Mail: graber@tema.de


**Figure 4.7 – 14 Invitation Flyer by LONMARK Germany (Registration /Agenda)**

In Germany, Switzerland and Austria in total 9 seminars and workshops were held with a total of 128 attendees. The high number in the two Swiss events was due to the fact that it was scheduled together with another LONMARK event which attracted many people from the Swiss LON community.


| No.                      | Date       | City       | No. of participants |
|--------------------------|------------|------------|---------------------|
| <b>1</b>                 | 2007-10-07 | Zurich     | 53                  |
| <b>2</b>                 | 2007-10-31 | Bern       | 21                  |
| <b>3</b>                 | 2008-04-23 | Nuremberg  | 5                   |
| <b>4</b>                 | 2008-04-24 | Stuttgart  | 5                   |
| <b>5</b>                 | 2008-05-06 | Frankfurt  | 13                  |
| <b>6</b>                 | 2008-05-08 | Dusseldorf | 13                  |
| <b>7</b>                 | 2008-05-14 | Raunheim   | 4                   |
| <b>8</b>                 | 2008-05-15 | Hörstel    | 9                   |
| <b>9</b>                 | 2008-05-27 | Vienna     | cancelled           |
| <b>10</b>                | 2008-05-28 | Salzburg   | 5                   |
| <b>Total Switzerland</b> |            | <b>2</b>   | <b>74</b>           |
| <b>Total Germany</b>     |            | <b>7</b>   | <b>54</b>           |

**Table 4.7 – 15 Seminars and Training Workshops in G, A,CH: attendees per event**

As can be seen the program was well balanced covering the fundamentals of safety and IEC 61508, the technical challenge and the SAFETYLON solution, tools and testing, and, last but not least, the Beta program.



# Agenda



**Begin: 09:30**

1. Safety Applications in Building Automation and in Industrial Applications
2. The IEC 61508 Standard and its application in networked safety systems

**Coffee Break**

3. Possibility of failures in serial communication and its elimination / reduction
4. The SafetyLon EU Project – from idea to implementation

**Lunch: 12:30 until 13:30**

5. Development principles of safe hardware and its implementation for LON (SIL3)
6. Development principles of safe software and its implementation on a SafetyLon reference hardware

**Coffee Break**

7. Installation principles of a SafetyLon network by use of standard LNS tools and special Plug-Ins
8. Development of safe prototype applications targeted at building automation
9. Test environment for SafetyLon products and the procedure of conformance testing
10. The SafetyLon Beta program

**End: approx. 16:30**

Copyright © 2008 LonMark  
Deutschland e.V. 2

### Slide 4.7 – 16 The seven hour seminar / training workshop program

The feedback from most participants was very positive both with regard to the content – which was a new subject for many – as well as to the quality and the educational character of the presentations. There was often expressed admiration for the technical challenge that the Consortium had taken on and obviously mastered within the FP6 program.

Also the training sessions were very well prepared in a joint effort of AGH-UST and ICT. The training kit was designed to demonstrate all different possibilities of fault infliction and the reaction of the system.




**Picture 4.7 – 17 Seminar in Frankfurt**




**Picture 4.7 – 18 Demo during Training Workshop in Raunheim**

The seminars in Zürich and Bern were very well attended, as can be seen by the picture below. Note: due to the the perfect organisation of the SAFETYLON seminar in conjunction with a LONMARK event on “Energy and Technology” there was a very good attendance.



Herbstseminare 2007  
**Safetylon**  
IEC 61508 SIL 3



**23. Oktober 2007**  
Zürich, Flughafen  
**31. Oktober 2007**  
Bern, Stade de Suisse


**Sichere Applikationen in der Industrieautomation**

In der Industrie spielt die Sicherheitstechnik eine elementare Rolle. Mit Safetylon lassen sich auch Betriebsanlagen so ausstatten, dass die Prozess- und Gebäudeautomation durchgängig integriert wird - beispielsweise bei der Prozessüberwachung inklusive Brandschutz in Industriehallen. Ganzheitliche Sicherheitstechnik eine herausragende Eigenschaft von Safetylon.


LonMark®Schweiz informiert an seinen Seminaranlässen am 23. Oktober 2007 im Flughafen Zürich und am 31. Oktober 2007 im Stade de Suisse in Bern ausführlich über das Projekt Safetylon und dessen Anwendung.

Melden Sie sich jetzt an und sichern Sie sich Ihren Platz an einem der informativen Seminare von LonMark®Schweiz.

Dieses Seminar richtet sich an Ingenieure aus den Bereichen Sicherheitstechnik, Entwicklungs- und Systemtechnik.



[www.lonmark.ch](http://www.lonmark.ch)  
lonMark®Schweiz - Kasernenstrasse 6 - CH-3600 Thun - info@lonmark.ch



Um in der Gebäudeautomation und anderen prozessorientierten Systemen sichere - im Sinne der IEC 61508 - und nicht sichere Anwendungen miteinander kombinieren zu können, wurde im Jahre 2005 ein Förderprojekt mit der Bezeichnung Safetylon beantragt und gewonnen. Das Projekt wird von 17 europäischen Partnern getragen, die in gemeinsamer Anstrengung die Hard- und Software für Safetylon spezifizieren und entwickeln, sowie eine Reihe von Geräten für die sichere Gebäudeautomation bauen.


**Programm**

**Europäisches Projekt zur Entwicklung sicherer Netzwerke auf Basis EN 14908 (LON)**

|       |   |
|-------|---|
| 9h00  | Sichere Datentransaktion als Grundlage<br>Dr. Ing. Peter Wralli, Innotec                      |
| 9h20  | Das Safetylon EU-Projekt - von der Idee zur Lösung<br>Dr. Phys. Jürgen Hertel, Projektmanager |
| 9h40  | Die technische Lösung Teil 1: Hardware<br>Dr. Ing. Dietmar Loy, Loytec Electronics GmbH       |
| 10h20 | Die technische Lösung Teil 2: Software<br>Dipl. Ing. Philip Rikli, Intranet Partners          |
| 10h40 | Die technische Lösung Teil 3: Installation<br>Dipl. Ing. Martin Mantel, TPM Safetylon         |
| 11h00 | Entwicklung von Anwendungen<br>Dipl. Ing. Christoph Brännmann, Intranet Partners              |
| 11h20 | Zusammenfassung - Fragen & Antworten  |

Anschließend an das Seminar findet ein Stehstundli statt. Bitte melden Sie sich über unsere Homepage an. Die Teilnahme ist kostenfrei.

Wir möchten Sie darauf hinweisen, dass am Nachmittag das Seminar „Energie + Technologie“ stattfindet. Mehr Informationen dazu finden Sie auf unserer Homepage.



[www.lonmark.ch](http://www.lonmark.ch)  
lonMark®Schweiz - Kasernenstrasse 6 - CH-3600 Thun - info@lonmark.ch

**Picture 4.7 – 19 Invitation Flyer for seminars in Zurich and Bern**



**Picture 4.7 – 20 Attendees at the Zürich SAFETYLON workshop**

## 4.7.6 LUS Activities in WP 7

Also in the Nordic countries Lon Users Sweden organized a number of seminars and training workshops along the decisions of the IAG panel and based on the English Language material of the SAFETYLON Modular Workshop. Here is the announcement and invitation to the representatives of LUS in 11 Swedish locations announcing 12 seminar and training workshop events.

### Anders Blom (Naronic)

**From:** Anders Blom (Naronic) [anders@naronic.se]  
**Sent:** 13-maj-2008 12:31  
**To:** 'post@lonmark.se'  
**Subject:** Meddelande (<http://www.lonmark.se/news/News20080514.html>)



## Nyhet från LonMark Sverige

### SafetyLon

SafetyLon är ett 3-årigt EU-projekt med 17st företag ingående där LonMark Tyskland, LonUser Poland och LonUser Sverige ingår som produktägare till en kommande teknikplattform som skall tillåta att man kan integrera felsäkra system i befintliga fastigheter. Begreppet kallas Safety och redan nu finns det flera Safety-bussystem som exempelvis Can/Profibus m.m.. Skillnaden med Safety på Lon är bland annat att man kan skapa felsäkra installationer på öppna nätverk. Även felsäkerheten kommer att ökas i systemet. Som ett exempel kan nämnas att ett nödstopp till en hiss kan garanteras en maximal felfrekvens med ett fel vart 29.000 år. De viktigaste funktionerna i en fastighet är oftast rök-gasevakuering och utrymning av folk som befinner sig i fastigheten vid brand.

Vi kommer under maj månad att genomföra ett antal seminarier i Sverige. Dessa är en introduktion och är på cirka 2.5 timmar. Nedanstående städer är för närvarande aktuella:

Stockholm Syd 09.00 22:e maj  
 Sockholm Norr 14.00 22:e maj

Malmö 09.00 26:e maj  
 Växjö 14.00 26:e maj  
 Jönköping 09.00 27:e maj  
 Linköping 14.00 27:e maj  
 Örebro 09.00 28:e maj  
 Eskilstuna 14.00 28:e maj

Luleå 08.00 29:e maj  
 Umeå 14.00 29:e maj  
 Sundsvall 08.00 30:e maj  
 Gävle 14.00 30:e maj

Målgruppen är primärt tillverkare/konsulter/integratörer.  
 Anmälan görs direk till kansliet enligt nedan.

Väl mött.

### Picture 4.7 – 21 Invitation to 12 seminars / training workshop locations in Sweden

| <b>Deltagerliste</b>   |                         |
|--|-------------------------|
| Safety Lon   |                         |
| 6. maj 2008 kl. 10:00 til kl. 15:00                                  |                         |
| på TEKNIQ installatørernes organisation                              |                         |
| Paul Bergsøes Vej 6  |                         |
| 2600 Glostrup  |                         |
| <b>Firmanavn:</b>  | <b>Deltagernavn:</b>    |
| Lindpro a/s<br>Postboks 329<br>Fabriksparken 58<br>2600 Glostrup     | Bent J. Jeppesen        |
| Balslev A/S<br>Produktionsvej 2<br>2600 Glostrup                     | Per Nilstad             |
| G4S Security Services A/S<br>Roskildevej 157<br>2620 Albertslund     | Anders Lund Frederiksen |
| JT Engineering ApS<br>Postboks 561<br>Bytorvet 4<br>2620 Albertslund | Jørgen Toft             |
| E. Kallesøe<br>Generatorvej 35 B<br>2730 Herlev                      | Thomas Blume            |
| ALECTIA A/S<br>Teknikerbyen 34<br>2830 Virum                         | Kenneth Christiansen    |
| Honeywell A/S<br>Strandvejen 70<br>2900 Hellerup                     | Peter Fritzbøger        |
| Edvin Sanggaard<br>Rugmarken 13<br>Hjallese<br>5260 Odense S         | Edvin Sanggaard         |
| Exhausto A/S<br>Odensevej 76<br>5550 Langeskov                       | Kaare S. Jørgensen      |
| Solar Danmark A/S<br>Industrivej Vest 39<br>6600 Vejen               | Claus Skov              |
| Insight Building Automation ApS<br>Højbovej 1 F<br>8600 Silkeborg    | Alan Nielsen            |

**Picture 4.7 – 22 List of attendees of the Malmö event on May 22, 2008**

## **4.8 Work Package 8: Project Management (Jürgen Hertel, Martin Mentzel)**

### **4.8.1. Objectives**

According to the DoW the objectives of the project management workpackage concern the following issues:

- (1) conduct a professional project management based on the web based project management tool "Projectplace"
- (2) assure that the project plan is understood and followed by all RTD, SME and IAG partners as closely as possible
- (3) recognize the deviations and delays from plan as early as possible and take corrective actions
- (4) keep all project partners fully informed about the project at all times
- (5) conduct the financial and administrative project management interface to the EU

### **4.8.2. The Web based project management tool *Projectplace***

The project management system *Projectplace* was officially introduced on the first preparatory Consortium Meeting in Berlin. Although the system has many beautiful features it is the repository and archiving functions which are most important. With a consortium as diverse and spread out throughout Europe the system enforces discipline with regard to reading and writing information and reviewing documents in a timely fashion. Also the preparation of and the invitation to meetings for the various groups can be handled in an efficient way. Finally, reporting contributions and the management of decision making and the monitoring of task assignments can be perfectly handled with *Projectplace*. There are, however, still a number of missing or deficient features which need improvement. All in all *Projectplace* has been accepted very well by the Consortium partners and has become an indispensable part of project management.

### **4.8.3. The DoW Project Plan**

The DoW project plan has been repeatedly and extensively discussed in the plenary of the consortium meetings and in more detail in the various panel meetings. All planning and execution documents systematically reference the work packages, sub-workpackages and the changes made over time. [The updated actual Deliverables vs. Plan can be found in Appendix 2, Tables 8.0 -1, 8.0 -2 and 8.0 -3 as well as in the Gantt Chart 8.0 -4.](#)

As it turned out a linear bar chart plan is not sufficient for a complex project like SAFETYLON and its many interdependencies between work packages and sub-work packages. What is needed here is an enhanced plan which describes not only the output / supply of (sub-) work packages at a particular time but also the expected inputs / demand from the receiving (sub) work package. Despite of all the formal and informal communication the RTD panel suggested and the PMC approved a special RTD planning meeting in Vienna on July 11, 2006 which will pick up all the "lose ends" and tie them together to a meshed plan. The work packages effected the most are WP2, WP3 and WP4 where it is expected to save 10-15% of

time by a more refined planning and respective execution. The person in charge will be the Technical Project Coordinator.

For the DoW Version 2.0 an updated Project Plan and Milestone Plan have been created. It assumes that the entire project will be extended by 6 months. It is clear to the CM and to the PMC that some of the partners must reduce their activities significantly due to the fact that they are engaged in other activities, and that their planned budgets have been consumed. Nevertheless, the PMC will make sure that there is some contingency money left which would allow to pay for individual days of consultancy, if needed.

#### **4.8.4 Deviation and Delays and Corrective Actions taken (J. Hertel, M. Mentzel)**

Until the end of the project the DoW plan has been astonishingly accurate and has remained the “measuring stick”. As explained in full detail in chapter 3.6 the accumulated delay of the updated plan amounts to about three months, depending on the work package. During Period II the delay increased to even six months primarily to delays in WP2. Several corrective actions have been taken in order to curb any further delays. These measures are:

- a more detailed meshed planning and execution of reporting period II (see 4.8.3)
- shifting of activities between work packages 2, 3 and 4
- eliminating the optional implementation and testing of a Powerline channel
- creating a universal reference design PCB which can be used for prototyping and application development by all SMEs (rather than every SME developing its own custom PCB)
- this reference design kit also serves as the basis for the training kit developed by AGH-UST and LMD
- concentrating the testing of WP3 precisely on the requirements of TÜV
- facilitating the mutual help of consortium members by formalising the cross-charging of consortium members on cost basis of the receiving partner. Unfortunately this subject matter had not been covered in the Consortium Agreement.  
Note: by the end of the project not a single partner had made use of this option.
- 
- establishing a *Software Review Team* as part of the IEC61508 quality assurance to review, synchronize and align the individual RTD development results.
- Establishing a *Documentation Review Team* as part of the IEC61508 quality assurance to scrutinize and review all project documentation and put together a collection of documents to become the “official” deliverables for the SAFETYLON License Agreement (ANNEX II of SLA, see Table 4.1 -1)

#### **4.8.5. Communication with contractors (JH, MM)**

So far the services of two main contractors have been solicited: TÜV Rheinland and the Patent Lawyer Office Samson and Partner, Munich. After several sessions of the Consortium Manager and the Technical Project Manager with the patent lawyer Dr. von Pichler the PMC decided to give him restricted access to *Projectplace* and communicate all patent matters

---

through this medium, which has proven very effective. In contrast, the communication with TÜV Rheinland has been rather formal. It usually takes place at its headquarters in Cologne. By now we know all the TÜV decision makers and the safety specialists assigned to our project, and we understand their requirements and approval and certification procedures very well.

Shortly, the three IAGs will need the help of a specialist lawyer for European law to help us draft the Joint Ownership Agreement and the SAFETYLON License Agreement. For reasons of synergy and the specific knowledge about the SAFETYLON project, the patent lawyer office Samson & Partner, Munich, has provided initial drafts for both the Joint Ownership Agreement (JOA) and the SAFETYLON License Agreement (SLA), also. In addition, the three IAGs hired a small Munich Multimedia company (aimcom) to create a SAFETYLON Website which is scheduled to go “live” on October 1, 2007.

Although everything had been very well prepared for the SAFETYLON Website to go “live” during early 2008, the relationship with aimcom “deteriorated” somewhat since LMD was not able to pay the final invoice. We therefore agreed with aimcom to put the project in “sleeping mode” for a while and go public with the Website once we are able to pay. Aimcom and TÜV Rheinland are on the top of the list of open payments. Since we already established the JOEC Joint Ownership Exec Committee as successor group of the IAG panel this group will now be responsible for resuming the work and bring the website “online” without delay after LMD receives payment.

In the case of TÜV Rheinland the CM manager negotiated upfront that payment would only occur later. TÜV recommended to concentrate its work on an assessment of the development work of the Consortium and of the results with a projection to future safety device development rather than go for full type approval / certification of the core modules (see also details chapter 3.5.6 section (26)). The PMC accepted this recommendation on the one hand due to limited funding and on the other due to limited value of a type approved electronic module (the remainder of electronics, housing and connectors of a “real life” product).

#### **4.8.6. Financial and Administrative Management (JH)**

The Financial and Administrative Management is carried out in the LMD headquarters in Aachen. The Project Administrator takes care of general communication with the partners regarding meetings, training workshops, reporting, book keeping for LMD and all financial transactions. Time recording and time reporting is done by a specially developed spreadsheet which is tailored to every contractor collecting the monthly working hours per sub-work package. In its new version V2.1 it will be able to display the results as hours (or hours equivalents), funded costs or eligible (real) costs, and measures the actual costs versus the DoW plan. If all hours and other monthly costs have been inserted correctly, Form C will be automatically filled out.

The Time and Cost reporting Sheet V 2.1 has been used for Period II reporting. It was also used by the members to check on the correctness of Period I reporting. Wherever differences were discovered they have been carried forward in the “adjustment of previous periods” field in Form C for Period II. At any rate, the CM clearly stated to all consortium members that the TCRS is just a help to verify the correctness of their calculation from the original accounting documents.

---

After the extremely long duration of PII reporting and the problems that the members had encountered with filling out the Form Cs, the CM decided to significantly enhance the Time and Cost Reporting Sheet to its current version V2.3. Its main features are now:

- proper recording hours and other costs on a monthly basis with partial sums per period
- correction of hourly rates (relative to planned hourly rates),
- setting of the overhead factor for FC reporting (by period, and, if necessary, by month)
- the automatic generation of results in Form C format for PI, PII, PIII as well as for the total project, and
- directly from the basic data per month: hours, hourly rates, travel and consumable costs, subcontracting, overhead and total.
- the correct calculation of retroactive adjustments, e.g. in hourly rates, in case of reporting errors in a previous period in the Form C cells “Adjustment of previous period(s)” (AB41, AF41, AH41, AL41). These deviations had been inserted incorrectly in many cases and were subsequently corrected.
- the correct calculation of the Requested Financial Contribution (FC) in cell AL/AM62
- the correct printing of the Form Cs ready for signing.

Most of the members used the TCRS V2.3 for the PIII Form C reporting, and even those who did not (mainly the universities for reasons of own accounting practices) used it for comparing the results and assessing the deviations. In all cases the deviations turned out to be small. In cases where in the course of the project different personnel with different hourly rates was employed, the TCRS could verify the total result at an average hourly rate which, of course, deviated from the planned hourly rate. For example, ICT has used throughout the project an effective hourly rate of 19,75 € EC, whereas the plan had been set up with an hourly rate of 28,13 € which means ICT has put in 42,4 % more time and manpower into the project than originally planned. This calculation was essentially confirmed by ICT.

Collecting the various contributions of the members through correspondence and *Projectplace* proved to be very difficult and time consuming which was the main reason why PIII reporting was delayed several times. Some cases went very smoothly but some extremely unnerving which probably is to be expected in a European Consortium of 16 technically oriented members. In recognition of the fact, though, that they had not seen any funding for quite some time it must be acknowledged that their interest shifted quickly to revenue generating normal business.

By now all contributions have been provided varying in volume and quality, also to be expected. This report now brings all these contributions together to finalize the project.

#### **4.8.7. Milestones and Expected Results (JH)**

The milestones of the project within the reporting period I have been missed like most of the Deliverables, as previously reported. This report contains an updated milestone report in a new table format (see Table 8.0 – 3) Almost all milestones are delayed in reporting period I, and also in period II. . The only way to recover from the delay is the extension of the project by six months.

Due to the updated financial plan of DoW V2.0 and the extension of the project to 36 months the Consortium was able to recover from the delays accumulated in Period I and Period II and finish all the Deliverables in time, except D30 (Final reporting, which took much longer than

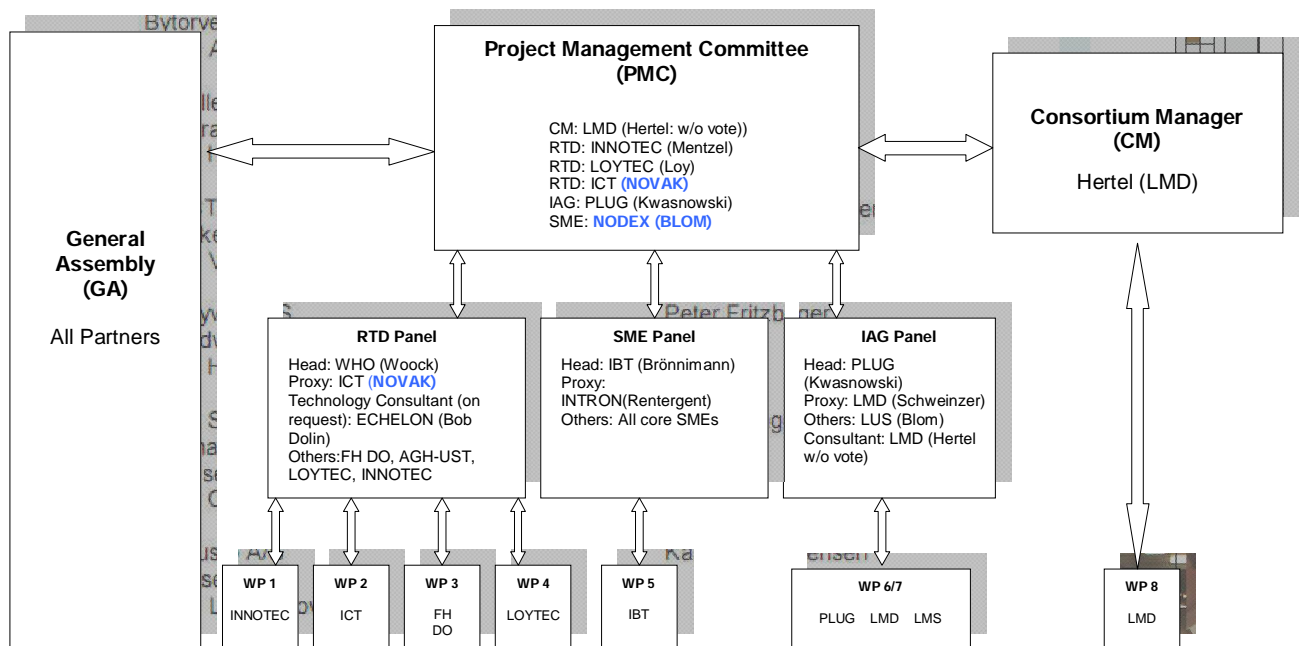
---

expected due to various reasons discussed above). On recommendation of TÜV Rheinland and decision by the PMC. Deliverable D26 was treated more pragmatically than originally planned mainly for reasons of future value but also for cost reasons. In summary, it can be said that the desired R&D results and the SME applications derived therefrom have been fully achieved as laid out in the original DoW, and later confirmed in the DoW V 2.0.

## 5. Consortium Management (J.Hertel, LONMARK Deutschland e.V.)

The Consortium Management proves to be a challenging task. For one it is necessary to stay focussed on the objectives of the project and avoid undesired deviations and sidetracks. This requires a good and indepth understanding of the work performed in the different work packages. On the other hand, it is important to keep the consortium in sync with all the information, changes to the plan, and decisions of the PMC which is a time consuming management task. In the DoW an organisation chart was proposed which has been implemented with only a few changes (see Figure 5.0 - 1: Updated Organisation chart of the Consortium (since May 23, 2007).

In PIII two changes in the PMC became effective: T. Novak of ICT replaced P. Palensky and AndersBlom of Nodex replaced C. Brönnimann. So the PMC stayed in full size throughout the project.



**Figure 5.0 - 1: Updated Organisation chart of the Consortium (since May 23, 2007)**

The Project Management Committee (PMC) has assumed its responsibilities as described in the DoW on June 30<sup>th</sup>, 2005 in Krakow. Its composition has slightly changed relative to the DoW. The PMC has been upgraded to six members and consists of the Consortium Manager (without vote), three RTD representative and the speakers of the SME and IAG panels. The PMC has been endowed by the Consortium with a total eligible cost budget of 114.2 k€ or 79.9 k€ requested contribution (which is 4% of the total budget). The PMC has taken a number of guiding decisions, both technical and non-technical. In the first reporting period the PMC met five times. Since then the PMC has decided to pay the Technical Project Coordinator from its budget, as well as several other major “consortium” expenses like the Projectplace License fee (20 k€), and the costs for the hardware produced by Loytec and WHO (approx. 30k€).

---

One of the first decisions of the PMC was to use a simple off-line spreadsheet as a common method for time and cost recording and reporting. The TRS V1.0 which is frequently updated by all contractors and placed in *Projectplace* was the first step. In a second version the TCRS V2.1 was released in 4/2007 and it will provide features like the comparison of actual data versus plan - both as values and bar charts - as well as an automatic filling in of Form C – provided all data have been inserted correctly.

Most of the panel and PMC meetings were hosted by the Institute for Computer Technology (ICT) under the directorship of Prof. D. Dietrich of the University of Vienna proving an ideal and technically professional setting. It also has proven to be the most cost effective meeting point regarding travel and subsistence costs.

Sofar, the entire Consortium has met 4 times in Berlin, Krakow and Hamburg and Vienna. In all cases the meetings were preceded by meetings of the RTD panel, the IAG panel and once the SME panel in order to save travelling cost and make best use of the participants' time. The Consortium meetings have always been accompanied by some social get-together to strengthen the group spirit and create an opportunity for members to get to know each other better on a personal basis. The Consortium meetings have proven a perfect occasion not only for the discussion of day to day matters, problems encountered, legal and reporting issues, but they also provide an opportunity for the WP leaders for presenting their plans for the next reporting period and beyond.

In summary, the project has had a slow start mainly due to the insufficient knowledge of most of the contractors regarding IEC61508 and the complexity of safety. And secondly, due to a safety architecture in the DoW which turned out to be problematic. Both deficiencies have now been overcome and the expected results are not only of higher quality but will open many business opportunities for the SMEs involved in the project as well as for new adopters of the SAFETYLON technology.

In Period III the main decisions of the PMC concerned three subjects: that have to do with quality assurance and the task to be assigned to TÜV Rheinland in conjunction with Deliverable D26:

1. the establishment of an RTD Document Review Team in which all RTDs volunteered at least one engineer. The objective was, as the name indicates, to improve the quality and completeness of all documents generated during the course of the project. Another objective was to create a list of documents as Deliverables as part of the SAFETYLON License Agreement (SLA). This list is now ANNEX II of the SLA (see Table 4.1 -1)
2. the set-up of the SOS Software Review Team as part of the Quality Assurance activity under WP 1. This team consisted of the TPC (Martin Mentzel) as leader, Michael Kieviet (Innotec), Henning Woock (who), Chris Brönnimann (IBT) and Thomas Novak (ICT). About the work performed by this team and the results see chapter 6.2 by the TPC.
3. the realignment of the assignment of TÜV Rheinland regarding the benefit / costs ratio of a type approval versus an assessment of the development work of the Consortium in accordance with IEC 61508 (see chapter 6.2, see also chapter 3.5.2 (26)).

## **6. Other Issues**

### **6.1. Contributions of the Industrial Associations/Groupings (J.Hertel)**

The IAGs have, in accordance with their role as owners of the IPR, contributed to the medium and long term success of the SAFETYLON technology by defining and agreeing upon the terms and conditions at which such IPR shall be marketed and licensed in Europe. All three IAGs volunteered to co-finance the costs of a European lawyer to draft a Joint Ownership Agreement (JOA) and a SAFETYLON License Agreement (SLA). Further, the IAG representative in the IAG panel helped to draft a plan for exploitation and dissemination of the Knowledge (see Deliverable D4).

The IAG LONMARK Germany has made special financial contributions by co-financing the Consortium Manager, the Technical Project Coordinator (the financing of the TPC was retroactively transferred to the PMC account) and the Project Administrator. It also carries the burden of co-financing the two major subcontractors of the project, TÜV Rheinland and a patent lawyer. Note: the latter imbalance will be corrected proportionally in the final payment to both IAGs PLUG and SME.

In Period III the IAG panel met frequently in order to finish all the open issues that had been partially, but not fully completed in PII, i.e. the modular seminar and training workshop presentations; the SAFETYLON Website, the Joint Ownership Agreement (JOA), the SAFETYLON License Agreement, preparing the details of seminars and training workshops in the three territories, providing input to the PMC regarding Deliverable D26, preparing for the time after the end of the project. The panel also discussed and agreed on the principles of cost sharing of the excessive, i.e. non-planned subcontracting costs (Note: as a result of the replanning of DoW V 2.0 during PIII the total EC for subcontracting went up by more than 100% to 212 k€).

As a result PLUG and LUS “owe” LMD an amount of 20.809,00 € each.

Meanwhile all three IAG boards have signed the JOA (details see Figure 4.6 – 5). Therefore, all the conditions for a joint marketing of the SAFETYLON technology in form of licensing are fulfilled.

### **6.2. Contributions of the RTD Performers (M. Mentzel)**

The participating RTDs have assumed their roles assigned to them by the DoW very seriously and responsibly. All RTDs have made significant contributions in their respective work packages. Particularly noteworthy at the beginning of the project were the contributions of Industrial RTD performer Innotec who has been the only “safety expert” in the consortium. Later, when it became clear that the DoW concept would not work it was the ICT of the Technical University of Vienna who advocated the more challenging but also more risky task of writing “our own” Safety Operating System (SOS) just committing its time and resources regardless of the plan. All RTDs contributed also by communicating and explaining their

---

work and documents to the SMEs thereby providing the grounds for their application work later on in the project.

During the reporting period II it became clear that ICT and the PMC had underestimated the amount of work of writing a Real Time Operating System and all associated interfaces as well as a special Application Programming Interface (API) for a three processor architecture. As a consequence the PMC decided to ask the three IAGs to transfer 50 k€ into the ICT budget in order for ICT to complete the development.

With founding and supporting the Review Team RTDs made a big contribution to the quality assurance process by improving their developments and participating in meetings and telephone conferences. This was a basic prerequisite for the assessment and the reporting results provided by TÜV Rheinland.

All development documents, safety-related calculation documents and the core module prototypes have been submitted to TÜV Rheinland. In an accompanying process with support by INNOTECH TÜV Rheinland provided the report of the certification process for a generic SAFETYLON node on April 24, 2008. With this report TÜV Rheinland certifies that the development results are a good basis for type approvals of SAFETYLON products which is a major milestone in our project.

While finalizing their prototypes SMEs were extensively supported by RTDs through documentation, templates, workshops, trainings and on an “as needed” basis. In the course RTDs guaranteed the knowledge transfer to the SMEs as well as the quality, integrity and completeness of the SME’s prototypes.

To ensure a high quality performance of the training activities carried out by the IAGs all RTDs supported the preparation and execution of training workshops. The material and the experience gained will also help the IAGs to execute trainings beyond the scope of the project.

### **6.3. Contribution of the SME Core Group (Ch. Brönnimann)**

The contribution of the SME core group in the first reporting period was – in accordance with the DoW plan – relatively small. It consisted mainly of learning and understanding the work of the RTDs, and supporting Work Package 1 by providing specifications of their respective prototype applications (see Deliverable D2). Noteworthy in particular are the contributions of Swiss SME partner IBT (Chris Brönnimann) who has assumed the responsibilities of the SME panel leader and SME representative in the PMC. It was due to Chris’ personal effort that all SMEs were able to properly describe the requirements for their prototype devices.

In period II the SME’s were still mainly in a “waiting and preparation position” since the development of ICT had been further delayed. However, in January and May 2007 the RTDs carried out two workshops educating and preparing the SMEs for their developments. In the last two day workshop the SMEs were handed out their complete hardware development kits and software development environment. Since then they are getting more and more familiar with their kits and are starting their own developments. The prototype applications of WP 4 (emergency pushbutton from WHO and logic element from Loytec) as well as many other testing applications from AGH-UST and ICT will be available shortly, so that there are plenty of examples to learn from.

In Period III the contribution of the SME core group was – in accordance with the DoW plan the major part of the SME activities. Due to the project delay and the related delays in payment this contribution had to be a fully pre-financed activity for many of the SME's. This was coupled with a period of high demand for engineering services in most of the markets in which SME's participate. The significant efforts could only be fulfilled by hiring additional staff or by staff supporting the project delivering overtime efforts. This pressure resulted in creating further project delays for the total project.

IBT joined as only SME the RTD staffed software review group in order to create a better information flow in between RTD and SME performers and also to gain indepth knowledge about the details and internals of the Safe Operating Scheduler (SOS). With the support of who, a standard development process / documentation framework was specified. This framework allowed the SMEs to exchange software source code among each other. While this was easing down the SME process SME's could put their focus on understanding the SOS enabling them to jump into the core software for future projects.

A further major contribution of SME's was the definition of a standardized system integration process brought to the LONMARK International standardisation process. This is done as a safety extension of the Node Object delivering key data like failure rates and the safety level of a single device for a total system failure rate calculation.

However, the main conclusion after the prototype development is that the safe system integration process for an open system like SAFETYLON has been underestimated. Major significant efforts have to be made for both, completing the SOS software to a market ready state and the improvement of the Safe System Integration Tool for delivering automated safe project management data. This is the hard learning aspect for the SME's since it will hardly be possible to continue this process with own resources and without a customer contract due to limited financial resources.

The positive conclusion is that a safe scalable networked system like LONWORKS is a true enabler for a next level of safe systems supporting, for example, dual safe states with automated systems. This was shown by the Escape Path Manager application where an Escape Path can be assigned depending on safe open or safe closed fire / smoke damper actuators. This means, that an Escape Path Manager can be assigned automatically and not only after a fireman on site decides by himself. In the process of a fire emergency in a big tower building, this may shift the "where to go for a safe exit" decision safely by 15 minutes or even more. In front of such opportunities, the SME core group still hopes to get the chance to continue the development paired with major capital investments.

---

## 7. Appendix 1: Plan for Using and Disseminating the Knowledge

The content of this Appendix 1 has been described in detail in chapter 4 of the main report under Work Packages WP 6.1 and WP 6.2. Therefore in this Appendix1 one just finds a summary of the content in form of tables as requested in the reporting guidelines. As we enter the work in both work packages within the next few months, the plans outlined below will turn more and more into execution plans with details who, when and where to be decided and included.

### 7.1. Exploitation of Knowledge

#### 7.1.1. Exploitable Knowledge and its Use

The exploitation of Knowledge and its planned activities including a first financial plan are described in detail under Work Package 6.1 in the main report and also in the Deliverable D4.

In order to better relate the exploitable results to the content of this document, following is a description or definition of the exploitable terms or items listed in column 2 of this table.

1. SAFETYLON Core Modules: a core module is the smallest physical unit which performs a standard hardware and software function. In our case this is a 70x70mm electronic module with three processors, one communication processor (either the FT3120 from Echelon or the LC3020 from Loytec) and two safety processors). The latter two run a standard Safety Operating System (SOS) including a so-called Safety Layer (SL). This module will be used by all core SMEs and later, by all Type B licensees who will develop SAFETYLON applications.
2. SAFETYLON installation and commissioning software: this WP3 software is required for the installation and commissioning of SAFETYLON devices to build a functioning safe network. This software is made available as source code to Type A and Type C licensees (see Deliverable D4), and as a finished software product to Type B licensees
3. Testing Software: this software is needed to test the behaviour of a safety device regarding its input and output signals in conjunction with either of the two core modules. It is made available to Type A and Type C licensees as source code and as a finished software product to Type B licensees. [It will also be made available as a service by AGH-UST in Krakow. The availability of such an independent and TÜV certified testing laboratory is a condition for SAFETYLON to become part of the EN 14908 standard.](#)
4. Reference Core Module, Neuron-FT3120 based: this core module is a prototyping hardware for SMEs which contains the FT3120 based SAFETYLON Core Module and a mother board with a limited amounts of digital I/O. This module serves as reference for all hardware and software developments, and all SMEs will base their device prototypes on this module. The reference core modules and the associated documentation will be part of all license types. The reference [module](#) concept will assure testability and quality of new designs by reference.

- 
5. Reference Core Module, LC 3020 based: same as 4. with LC3120 based SAFETYLON Core Module
  6. Concept approval by TÜV Rheinland: obtained on September 15, 2006. This approval - aside from the patent, when granted - will be a deliverable of all license agreements.
  7. TÜV certified Safety Operating System (SOS), Source and Binary: this software is the heart of the SAFETYLON technology. It will be tested and approved by TÜV in conjunction with the SAFETYLON core modules and the Reference Modules and the Safety Layer (SL). The SOS and the Safety Layer software (see Figures 3.8 – 1 and 3.8 – 2) will be made available as source code to Type A and Type C licensees. However, Type B licensees will only receive the respective documentation and will be able to purchase the code as embedded firmware in either of the SAFETYLON Core Modules.
  8. TÜV certified Safety Layer (SL), Source and Binary: part of the SOS, executes the SAFETYLON protocol. It is mentioned here separately since technically speaking it is a protected application task.
  9. SAFETYLON Interoperability Guidelines: these guidelines are an extension to the LONMARK Interoperability Guidelines and are needed by the core SMEs and future licensees of any type to develop interoperable SAFETYLON application software.
  10. Safety product approval of SOS including SL: this exploitable item is **not** part of this project, but is highly desirable to attain, since such a product approval would make the type approval of SME devices much easier and hence less expensive. Additional funding of approx. 200 k€ would be needed.
  11. Safety Testbed: this is a combination of a hardware assembly and associated testing software which will be needed to perform a system function test of the SME prototype developments. Once completed the test bed documentation will be a deliverable of a Type B license and will be made available as testing software source code to Type A and Type C licensees.



### 7.1.2. Clarification of IPR issues (last column of Table A1.1)

By design of the SAFETYLON project all new knowledge is being developed by the RTDs, is transferred to the IAGs by the Consortium Agreement and is managed by the IAGs under the Joint Ownership Agreement (JOA). The core SMEs are redeveloping currently existing non-safe applications on top of the Safe Application Programming Interface (SAPI). They will be using the Safe Application Development Environment (SADE) which is 100% IPR of the IAGs. In addition they will be using the Safe Installation Procedure (SIP) which is also 100% IPR of the IAGs.

In this process no genuinely new knowledge is generated on the part of the SMEs, irrespective of the type of application listed under Building Automation (see Activity Report for Period I, p.96, column 3, 1. building automation). All applications listed in the same column under 2. industrial automation, 3. transportation and 4. other safety related systems are not part of the SAFETYLON project and will be developed by other SMEs or OEMs under license. And even if any new significant IPR would be generated by an SME in context with its prototype development, it would be of no commercial interest or value to the Consortium in compliance with the respective clauses of the Consortium Agreement. The following table shows the IPR situation:

| <b>SAFETYLON IPR</b>                              | <b>IPR generated by (if any)</b> | <b>IPR owned and exploited by (if any)</b> |
|---|----------------------------------|--|
| Safety Application Prototype / Program            | SMEs                             | SMEs                                       |
| Safety Application Programming Interface (SAPI)   | RTDs                             | IAGs                                       |
| Safety Installation Procedure (SIP)               | RTDs                             | IAGs                                       |
| Safety Application Development Environment (SADE) | RTDs                             | IAGs                                       |

**Table 7.1 - 2: Overview table on Exploitable Knowledge and its Use**

## 7.2. Dissemination of Knowledge

The dissemination of Knowledge and the planned activities including a first financial plan are described in detail under Work Package 6.2 in chapter 4 of the main report and also in the Deliverable D4 section at the very end of the Activity report for Period I. The following table gives an overview:

| <b>Planned/ actual Dates</b> | <b>Type</b>           | <b>Type of audience</b>   | <b>Countries addressed</b>   | <b>Size of audience</b> | <b>Partner responsible /involved</b> |
|------------------------------|-----------------------|---|------------------------------|-------------------------|--------------------------------------|
| 10/2007                      | Press release (press) | General public;<br>LON User Groups;<br>Echelon Int'l distribution | All major<br>EU<br>countries | > 50,000                | LMD<br>LMS<br>PLUG<br>Local SMEs     |
| 10/2007                      | Media briefing        | LON User Organisations<br>Local trade press                       | All major<br>EU<br>countries | >1,000                  | LMD<br>LMS<br>PLUG<br>Local SMEs     |

| <b>Planned/<br/>actual<br/>Dates</b> | <b>Type</b>  | <b>Type of audience</b>   | <b>Countries<br/>addressed</b> | <b>Size of<br/>audience</b> | <b>Partner<br/>responsible<br/>/involved</b>       |
|--------------------------------------|--|---|--------------------------------|-----------------------------|--|
| 05/2008                              | Telephone and email prospecting  | Manufacturers<br>Systemintegrators<br>Specifiers  | S                              | >300                        | LUS  |
| 10/ 2006-<br>04/2008                 | Seminars, Roadshow   | Decision Makers of selected companies;<br>Engineers   | G, A, CH<br>S / NO, UK,<br>PL  | > 500                       | LMD<br>LMS<br>PLUG<br>Local SMEs                   |
| 05/2008                              | Seminars in 12 locations   | Systemintegrators<br>Specifiers   | SE, DK                         | 50                          | LMS  |
| 01/ 2007 –<br>05/2008                | Exhibitions, Tradeshows  | Building Automation<br>Safety Tradeshows<br>Industrial Automation   | Countries<br>of<br>contractors | > 1000                      | LMD<br>LMS<br>PLUG<br>Local SMEs                   |
|                                      | Publications: several<br>Articles and Scientific<br>Articles   | Trade press;<br>LONMARK Magazine<br>(European Edition)  | All<br>European<br>countries   | > 10,000                    | LMD<br>LMS<br>PLUG<br>Local SMEs                   |
| 10/2007                              | Project website -hosted by<br>aimcom; based on a Web<br>tool which allows<br>maintenance by laymen       | all LON Users members in<br>Europe;<br>planners, specifiers, safety<br>engineers  | All<br>European<br>countries   | > 30,000                    | LMD<br>LMS<br>PLUG                                 |
| 4/2006<br>and<br>4/2007<br>done      | Posters: panels for<br>Hanover Fair 2006 and<br>Light & Building 2008                                    | Visitors of tradeshows;<br>Participants in roadshow   | “tradeshow”<br>countries       | > 1,000<br>qualified        | LMD<br>LMS<br>PLUG                                 |
| 4/2006<br>10/2007                    | Flyers:<br>New Flyers in the<br>Languages of the<br>Consortium   | Visitors of tradeshows;<br>Participants   | “tradeshow”<br>countries       | > 5,000                     | LMD<br>LMS<br>PLUG                                 |
| 09/10<br>2007                        | Direct e-mailing;<br>Invitation to seminars  | Planners, specifiers, safety<br>engineers, decision makers<br>from safety industry  | Limited by<br>budget           | >500                        | LMD<br>LMS<br>PLUG                                 |
| 01-<br>09/2007                       | Building up a library of<br>Powerpoint presentation<br>called the SAFETYLON<br>Modular Workshop<br>(SMW) | Visitors of seminars,<br>workshops, tradeshows,<br>conferences; identical “look<br>and feel”; flexible in length<br>and content | All<br>European<br>countries   | > 1,000                     | LMD<br>LMS<br>PLUG<br>All<br>Consortium<br>members |
|                                      | Film/video   | Currently not affordable;<br>Maybe running slide show<br>for tradeshows; planned for<br>the first “real” customer<br>project    | Limited by<br>budget           | >10,000                     | LMD<br>LMS<br>PLUG                                 |

**Table 7.2 - 1: Overview Table for Dissemination Activities updated for PIII**

Details about the events in which members of the consortium participated are described in the main report in chapter 4, WP6.2 and in the Deliverable D4 of the Activity report Period I section at the end of this document.

### 7.3. Publishable Results Activities

Until now only very few general articles have been published in various LON User publications. Now, since a patent has been submitted (see Deliverable D3 of Activity report Period I) several scientific publications are in preparation, e.g. by Dr. Peter Palensky of ICT, by Prof. Dr. Peter Fischer of FH Dortmund and by Pawel Kwasnowski of the University of Mining and Metallurgy, Krakow. Also, a more general article covering the requirements of IEC61508, the FP6 Collective Research project, the SAFETYLON concept and the technical solution is currently being prepared by the Consortium Manager for the next edition of the LONMARK Magazine Europe for LonWorWorld 2007 in Amsterdam (November 2007). It will be made available to all contractors for translation, adaptation and publication in their respective territories.

Note: in July 2007 the TUW organized and carried out an international event IEEE INDIN 2007 in Vienna. On this event the CM and several RTD and SME representatives gave a 4 hour Tutorial on SAFETYLON, and three other presentations were given during the conference. The presentations and printed papers will be downloadable from the SAFETYLON Website. There is one planned publication in the newspaper DETECTOR in Sweden, related to the Exhibition SKYDD in Stockholm.

In Period III a number of articles and papers were published (although mentioned in different parts of this report already, here is a complete list):

1. SAFETYLON – ein innovatives Konzept für sicherheitsgerichtete Anwendungen in der Gebäudeautomation (Dr. Jürgen Hertel: LONMARK Magazin, September 2007 (pp. 6 -11); Athor: Dr. Jürgen Hertel)
2. SAFETYLON – an innovative Concept to bring the Features and Benefits of LON to the SafetyRelated Building Automation Market (Dr. Jürgen Hertel: LONMARK Magazine, European Edition, Part 1, October 2007 (pp. 30 – 33) and Part II, January 2008 (pp.18 – 22))
3. Functional Safety and System Security in Building Automation and Control Systems – A Common Approach (T. Novak: Ph.D. Thesis, Vienna University of Technology, Institute of Computer Technology, Austria, Vienna, 2008 (to be published))
4. Netzwerkzeitsynchronisation in sicheren Feldbussystemen (B. Sevcik: M.S. Thesis, Vienna University of Technology, Vienna, 2007)
5. Hardware Selftests For Safety Critical Fieldbus Nodes (P. Preininger: M.S. thesis, Vienna University of Technology, Institute of Computer Technology, Austria, Vienna, 2006)
6. Architecture of a safe node for a fieldbus system (T. Novak, T. Tamandl: Proceedings of the 5th IEEE International Conference on Industrial Informatics, Vol. 1, pp. 101-106, 2007)
7. Online Self Tests for Microcontrollers in Safety Related Systems (T. Tamandl, P. Preininger: Proceedings of the 5th IEEE International Conference on Industrial Informatics, Vol. 1, pp. 137-142, 2007)
8. Testing Approach for Online Hardware Self Tests in Embedded Safety Related Systems (T. Tamandl, P. Preininger, T. Novak, P. Palensky: Proceedings of the 12th IEEE International Conference on merging Technologies and Factory Automation, pp. 1270-1277, 2007)

9. Network Time Synchronization in a Safe Automation Network (T. Novak, B. Sevcik: Proceedings of the 7th IEEE International Workshop on Factory Communication Systems, pp. 305-313, 2008)
10. Safe Commissioning and Maintenance Process for a Safe System (T. Novak, P. Fischer, M. Holz, M. Kieviet, T. Tamandl: Proceedings of the 7th IEEE International Workshop on Factory Communication Systems, pp.225-232, 2008)
11. Draft standard was submitted to the European standardization body CEN, Technical Committee 247, Working Group 4 (NoteT. Novak: The draft standard includes a lot of ideas and practical information gained during the work in the SAFETYLON project)
12. Further publications were published by the AGH-UST team on the SAFETYLON testing environment and result (to be delivered on request)

## 8 Appendix 2 – Actuals data of Deliverables in PIII

| Del. no. <sup>1</sup> | Deliverable name  | WP no. | Lead contractor | Estimated person-months | Nature <sup>2</sup> | Dissemination level <sup>3</sup> | Delivery date <sup>4</sup><br>(DoW month)                            |
|-----------------------|---|--------|-----------------|-------------------------|---------------------|----------------------------------|--|
| D1                    | Presentation of project   | 8      | LMD             | 1                       | R                   | CO                               | 11 (3)   |
| D2                    | Report on required specifications for different safety applications (SRS) -   | 1      | INNOTE C        | 2                       | R                   | CO                               | 9 (6)  |
| D3                    | Plan for exploiting IPR (SAFETYLON patent)  | 6      | LMD             | 1                       | R                   | CO                               | 11 (9)   |
| D4                    | Plan for Exploitation and Dissemination Activities during the project   | 6      | LNO DE PLUG LUS | 0,5                     | R                   | CO                               | 12 (10)  |
| D5                    | 12 months report  | 8      | LMD             | 2*                      | R                   | CO                               | 14 (13)  |
| D6                    | Included in D8  | 2      |                 |                         |                     |                                  |  |
| D7                    | Included in D8  | 2      |                 |                         |                     |                                  |  |
| D8                    | Safety Operating System (SOS); includes Safety Layer for ARM7<br>SAFETYLON Manual App Interface<br>Test Guidelines<br>Test Plan (White box)<br>Test Case Specification (White box)<br>Software Architecture Document<br>SW Requirements Specification | 2      | ICT LOYTEC WHO  | 43                      | R                   | CO                               | 31 (15)<br>with further stability updates during the months 32 to 36 |
| D9                    | Modified development tools for LONMARK objects<br>SAFETYLON Application Builder   | 3      | FH DO           | 12                      | R                   | CO                               | 32 (15)  |
| D10                   | Configuration and Installation tools for Neuron chip and LC3020 chip  | 3      | FH DO           | 28                      | R                   | CO                               | 32 (15)  |
| D11                   | Mid-term Review /<br>18 months report - Cancelled   | 8      | LMD             | 2*                      | R                   | CO                               | 24 (18)  |
| D12                   | Safety layer testing tool<br>Presentations in Projectplace  | 3      | AGH-UST         | 8                       | R                   | PU                               | 30 (21)  |

<sup>1</sup> Deliverable numbers in order of delivery dates: D1 – Dn

<sup>2</sup> Nature of the deliverable codes:

**R** = Report  
**P** = Prototype  
**D** = Demonstrator  
**O** = Other

<sup>3</sup> Dissemination level codes:

**PU** = Public  
**PP** = Restricted to other program participants (including the Commission Services).  
**RE** = Restricted to a group specified by the consortium (including the Commission Services).  
**CO** = Confidential, only for members of the consortium (including the Commission Services).

<sup>4</sup> Month in which the deliverables will be available. Month 1 marking the start of the project, and all delivery dates being relative to this start date.

|     |  |   |        |   |   |    |         |
|-----|--|---|--------|---|---|----|---------|
|     | Test Plan (Black boc testing)<br>Test Design and Test Case specification (Black box testing)<br>(RTH tool) <a href="http://www.rth-is-quality.com">www.rth-is-quality.com</a><br>Labview |   |        |   |   |    |         |
| D13 | Demonstrator module (Neuron), Docu, Picture of module)   | 4 | WHO    | 8 | D | PU | 24 (21) |
| D14 | Demonstrator module (LC3020 chip), Docu, Picture of module   | 4 | LOYTEC | 8 | D | PU | 24 (21) |

### 8.1. Table 8.0 - 1: Updated List of Deliverables D1 to D14 (see DoW V2.0) for PIII

blue = update for Period PIII

| Del. no. <sup>5</sup> | Deliverable name   | WP no. | Lead contractor | Estimated person-months | Nature <sup>6</sup> | Dissemination level <sup>7</sup> | Delivery date <sup>8</sup> (proj. month) |
|-----------------------|--|--------|-----------------|-------------------------|---------------------|----------------------------------|--|
| D15                   | 24 months report   | 8      | LMD             | 2*                      | R                   | CO                               | 27 (26)                                  |
| D16                   | Plan for Exploitation and Dissemination Activities after the project | 6      | PLUG            | 0,5                     | R                   | CO                               | 36 (27)                                  |
| D17                   | Demonstrator emergency lighting application                          | 5      | IBT             | 6                       | D                   | PU                               | 34 (30)                                  |
| D18                   | Demonstrator elevator application                                    | 5      | INTRON          | 6                       | D                   | PU                               | 34 (30)                                  |
| D19                   | Fire Damper Actuator, Safety Door and Escape Path Manager            | 5      | IBT             | 6                       | D                   | PU                               | 34 (30)                                  |
| D20                   | Demonstrator Fire Detection and Intrusion Protection                 | 5      | ZDANIA          | 6                       | D                   | PU                               | 34 (30)                                  |
| D21                   | Demonstrator Emergency Exit Button                                   | 5      | NODEX           | 6                       | D                   | PU                               | 34 (30)                                  |
| D22                   | Demonstrator access control unit                                     | 5      | APICE           | 6                       | D                   | PU                               | 35 (30)                                  |

<sup>5</sup> Deliverable numbers in order of delivery dates: D1 – Dn

<sup>6</sup> Nature of the deliverable codes:

**R** = Report  
**P** = Prototype  
**D** = Demonstrator  
**O** = Other

<sup>7</sup> Dissemination level codes:

**PU** = Public  
**PP** = Restricted to other program participants (including the Commission Services).  
**RE** = Restricted to a group specified by the consortium (including the Commission Services).  
**CO** = Confidential, only for members of the consortium (including the Commission Services).

<sup>8</sup> Month in which the deliverables will be available. Month 1 marking the start of the project, and all delivery dates being relative to this date.

|     |  |   |                    |    |   |    |                 |
|-----|--|---|--------------------|----|---|----|-----------------|
| D23 | Demonstrator Fault Indication and Switch Control panel                                 | 5 | UNITRO             | 6  | D | PU | 35 (30)         |
| D24 | Demonstrator safety-network management tool  | 5 | NEWRO N            | 6  | D | PU | 35 (30)         |
| D25 | Test-bed for demonstrator modules  | 5 | FH DO              | 6  | D | PU | 35 (30)         |
| D26 | TÜV assessment of R&D work and core modules  | 1 | INNOTE C           | 2  | D | PU | 35 (30)         |
| D27 | Training kit   | 7 | AGH-UST            | 6  | R | PU | 33 (24)         |
| D28 | Training courses for Consortium LON User Group members; min target: 8x10 = 80 trainees | 7 | LMD<br>LMS<br>PLUG | 1  | O | PU | 34 -36 (25-30)  |
| D29 | Training courses for Non-consortium attendees; min target: 10x10 = 100 trainees        | 7 | LMD<br>LMS<br>PLUG | 1  | O | PU | 34 - 36 (25-30) |
| D30 | Final report   | 8 | LMD                | 2* | R | CO | 42 (38)         |

## 8.2. Table 8.0 – 2: Updated List of Deliverables D15 to D30 (see DoW V 2.0) for PIII

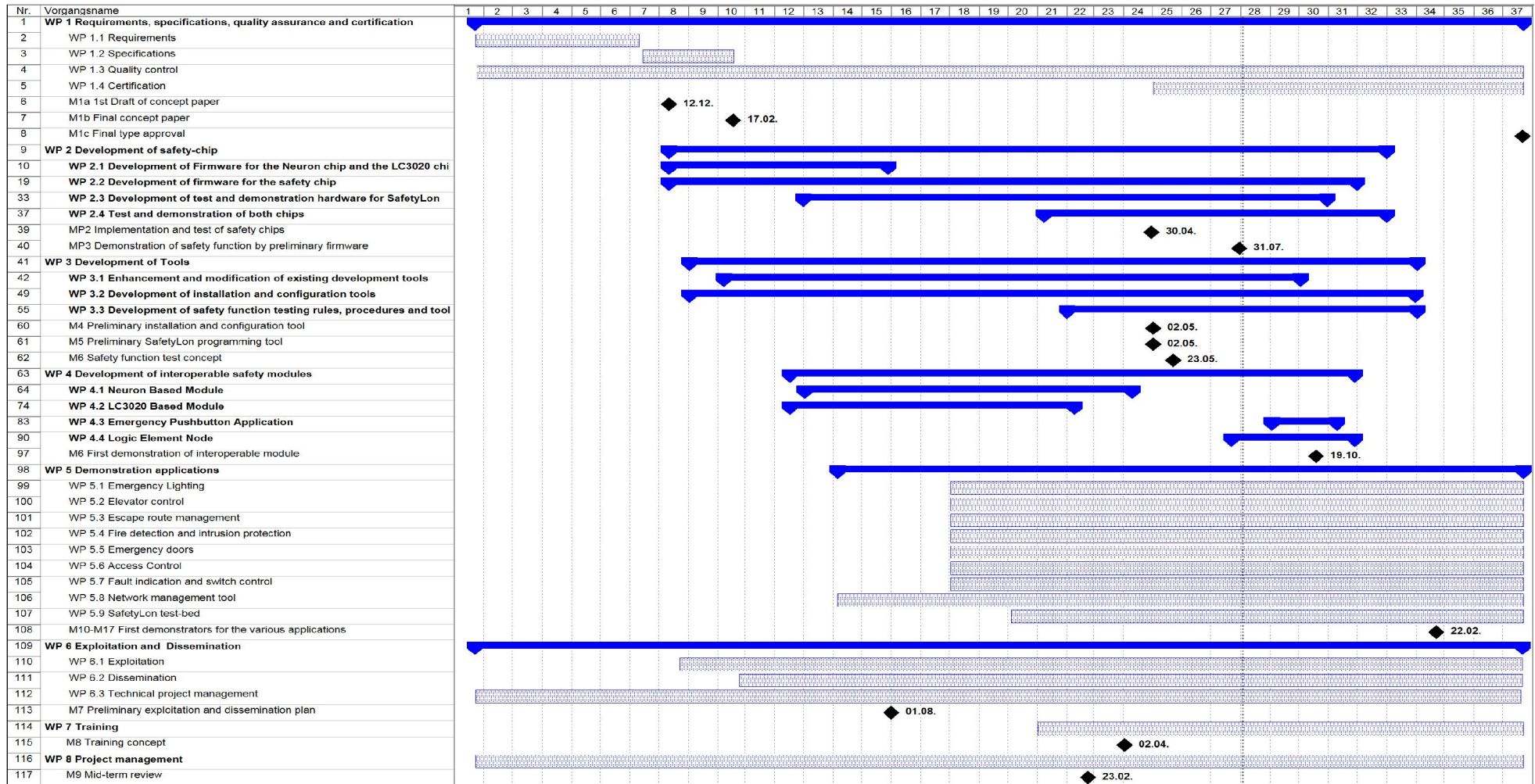
blue = update for Period PIII

\*For the reports the estimated work effort is split 50% to the participants and 50% to the coordinator/administrator

| <b>Milestone no.</b> | <b>Milestone name</b>  | <b>WP no.</b> | <b>Lead contractor</b> | <b>Date due (DOW project month)</b> | <b>Annual Forecast delivery date</b> |
|----------------------|--|---------------|------------------------|-------------------------------------|--------------------------------------|
| M1                   | First draft of concept paper   | 1             | INNOTEC                | 2                                   | 8 (2)                                |
| M2                   | Implementation and test of Safety chip   | 2             | ICT                    | 0,5                                 | 24 (9)                               |
| M3                   | Demonstrator of Safety function by preliminary firmware  | 2             | ICT                    | 6                                   | 27 (12)                              |
| M4                   | Preliminary installation and configuration tool  | 3             | FH DO                  | 6                                   | 24 (12)                              |
| M5                   | Preliminary Add-Ins for embedded application development tools fitting to the reference hardware | 3             | FH DO<br>LOYTEC<br>WHO | 6                                   | 24 (15)                              |
| M6                   | Preliminary Safety product test concept  | 3             | FH DO<br>AGH-UST       | 6                                   | 25 (15)                              |
| M7                   | Preliminary Exploitation and Dissemination Plan  | 6             | LMD<br>LMS<br>PLUG     | 6                                   | 14 (9)                               |
| M8                   | Training Concept   | 7             | AGH-UST                | 6                                   | 23 (18)                              |
| M9                   | Mid-Term review  | 8             | LMD                    | 6                                   | 22 (18)                              |
| M10                  | Demonstrator Emergency Lighting  | 5.1           | IBT                    | 6                                   | 34 (27)                              |
| M11                  | Demonstrator Elevator control  | 5.2           | INTRON                 | 6                                   | 34 (27)                              |
| 34M12                | Demonstrator Fire Damper Actuator, Safety Door and Escape Path Manager                           | 5.3           | IBT                    | 2                                   | 34 (27)                              |
| M13                  | Demonstrator Fire detection and intrusion protection   | 5.4           | ZDANIA                 | 6                                   | 34 (27)                              |
| M14                  | Demonstrator Emergency Exit Button   | 5.5           | NODEX                  | 1                                   | 34 (27)                              |
| M15                  | Demonstrator Access control unit   | 5.6           | APICE                  | 1                                   | 34 (27)                              |
| M16                  | Demonstrator Fault indication and switch control panel   | 5.7           | UNITRO                 | 2*                                  | 34 (27)                              |
| M17                  | Demonstrator network management tool   | 5.7           | NEWRON                 |                                     | 35 (25)                              |
| M18                  | SAFETYLON test bed (new)   | 5.9           | FH DO<br>AGH-UST       |                                     | 35 (25)                              |
|                      |  |               |                        |                                     |                                      |

### **8.3. Table 80 - 3: Actually Achieved Milestones from DoW V 2.0 (Gantt chart)) during PIII**

**blue = PIII achievements**



**8.4. Table 8.0 – 4 Gantt chart of achieved WP Milestones in the SAFETYLON project (M. Mentzel, TPC)**