

WAVEGEN



Project number: COOP-CT-2005-017766

Project acronym: WAVEGEN

Project title: Wave Pump Submersible Power Generator

Instrument: Cooperative Research

Thematic priority: "Sustainable Energy Devices"

Publishable Final activity report

Period covered: from M13 to M28	Date of preparation: 15/04/2008
Start date of the project 01/09/2005	Duration: 28 months
Project coordinator name Paolo De Stefanis	
Project coordinator organisation name LABOR Srl	Revision 0

TABLE OF CONTENTS

SECTION 1	Project execution	3
1.1	Project objectives	3
1.2	Contractors list	6
1.3	Work performed	8
1.4	Final results	10
1.4.1	WAVEGEN specifications and design	10
1.4.2	CFD analysis and simulations	21
1.4.3	System prototyping and installation	30
1.4.4	Assessment of deployment activities	42
SECTION 2	Dissemination and use	52
2.1	Description of exploitable results	52
2.1.1	All in one modular integrated system for sub sea power production	53
2.1.2	Modular project and design of subsea pumps	60

SECTION 1 Project execution

1.1 Project objectives

The energy sector is going through a renovating process, which sees its opening towards renewable energies; it's in the dynamic evolution of this emerging industry that a wave energy sector is emerging.

Although the technology is relatively new and currently not economically competitive with more mature technologies such as wind and solar energy, the interest from governments and industry is steadily increasing.

Wave energy, in fact, is an abundant renewable resource, which is starting to be exploited by several European countries and considerable progress has been made over the past decade in this sector in Europe, resulting in some technologies being at, or near, commercialization.

From this perspective, WAVEGEN represents an innovative step forward in the pursuit of reliable, economic and sustainable energy devices.

The WAVEGEN project proposes to investigate the integration of the WAVEPUMP, a proof of concept lightweight offshore wave energy converter, with a submersible hydraulic turbine, finalised at the development of a novel concept of submerged offshore wave energy converter, allowing direct conversion of wave energy into electrical energy.

The integration of the two technologies is extremely appealing and highly innovative, and has the potential to provide real sustainability to small wave energy applications, representing a potential breakthrough in the wave energy sector:

- The WAVEPUMP has already proved its operation through several tests as a stand-alone single device, providing exceptional results as far as yearly production and reduced installation costs are concerned¹ and requires to be improved and developed in a cluster configuration, to provide steady and constant water flow.
- Submersible hydraulic turbines are now entering the market, and allow innovative implementations never achieved so far.

There is a sensible amount of scientific and technical knowledge which requires to be generated in order to provide successful application to this approach, which is definitely all but a mere design of a simple integration.

The successful performance of the project requires multidisciplinary expertise in several research and technology areas, such as:

¹ Independent study from Danish Wave Power Committee (DWPC) “Bølgekraftsutvalget” – August 2002

- ✓ CFD (Computational Fluid Dynamics)
- ✓ Welding
- ✓ Submerged marine technologies
- ✓ Vibrations mechanics
- ✓ Fatigue design
- ✓ Power conversion
- ✓ Materials science (both plastic and metallic ones)
- ✓ Design for robustness
- ✓ Multivariable optimisation

Project objectives can be summarised as follows:

- Provide in depth analysis of the WAVEGEN concept, by:
 - Study clustering of WAVEPUMPS and model optimised integration of multiple WAVEPUMP energy converters
 - Model fluid dynamic phenomena occurring in such a system, and implement a complete computational fluid dynamic (CFD) parametric simulator
 - Perform virtual optimisation through the integration of the CFD model with the Experimental Design (ED) methodology, finalised at the achievement of the most efficient and constructive flow from the pumps into the turbine, maximising energy output, water turbine coupling and minimising fatigue stress over the structure
- Derive from the knowledge base generated through such a virtual optimisation approach, replicable criteria allowing the design of a modular multi-pump system in variety of sea conditions and sea wave energy spectra; a siting tool will be made available, based on the exploitation of the knowledge generated during the ED driven optimisation of the CFD parametric model.
- Develop and implement the best integration of the WAVEPUMP with the submergible hydraulic turbine; this will involve:
 - Dumping vibrations derived from oscillating water flows and consequently provide proper specifications of plastic and metallic materials
 - Ensure constructive and non destructive interactions among the flows coming from different pumps, improving conversion efficiency
 - Revise accordingly all accessories (like valves)

- Develop the WAVEGEN system in order to:
 - reduce the need of maintenance
 - secure a power plant extended production time
 - improve the total effect
 - reduce the risk of breakdown
 - reduced-cost production of cables, construction and laying offshore
- To be the most economical plant installation – criteria were:
 - Yearly production/installed capacity - target: highest values in the business
 - Installed cost/yearly production – target: Lowest value in the business
- To perform and document a series of testing, to assure the reliability of the WAVEGEN prototype
- To decrease the cost below 2USD/W – and 5p/kWh

The leading shove for this project is the search for a cost effective and reliable product able to open the wave energy market and make it grow into a profitable opportunity; WAVEGEN proposes to develop a modular, very low impact, off-shore wave energy converter, exploiting the above mentioned technology as well as an analytical approach (by Fluid Dynamic Simulation and Experimental Design optimization) to the design of the array of pumps.

By the end of the project, WAVEGEN will deliver the following demonstration prototype:

- 100 kW offshore submerged wave energy converter
- linear array made of 5 WAVEPUMP units made of standard polyethylene pipes, each approximately of the following size:
 - buoy diameter 3 m
 - buoy height 1 m
 - pump cylinder diameter 0.7 m, length 6 m
- piston rod diameter 0.2 m, length 15 m Pumps producing flow in a main pipe leading to the sub-sea energy converter, all installed in a common anchoring platform.
- The total length of the platform is defined by half a wavelength - 15 to 20 meter.
- The distance between the pumps eliminates pulsation in the main pipe leading to the energy converter.
- Installation depth around 20 meter.
- The 5 pumps will deliver 350 l/sec at 4 kg pressure (100 kw) when working in the average wave regime at Madeira

- Pumps producing flow in a main pipe leading to the sub-sea energy converter, all installed in a common anchoring platform

The system will allow easy clustering into arrays and delivery of flow from a number of pumps into a common sub-sea power generator, or traditional onshore hydropower converter; if the pumps are installed in a strategic distance in the wave amplitude, the pulsating flow to the converter is eliminated.

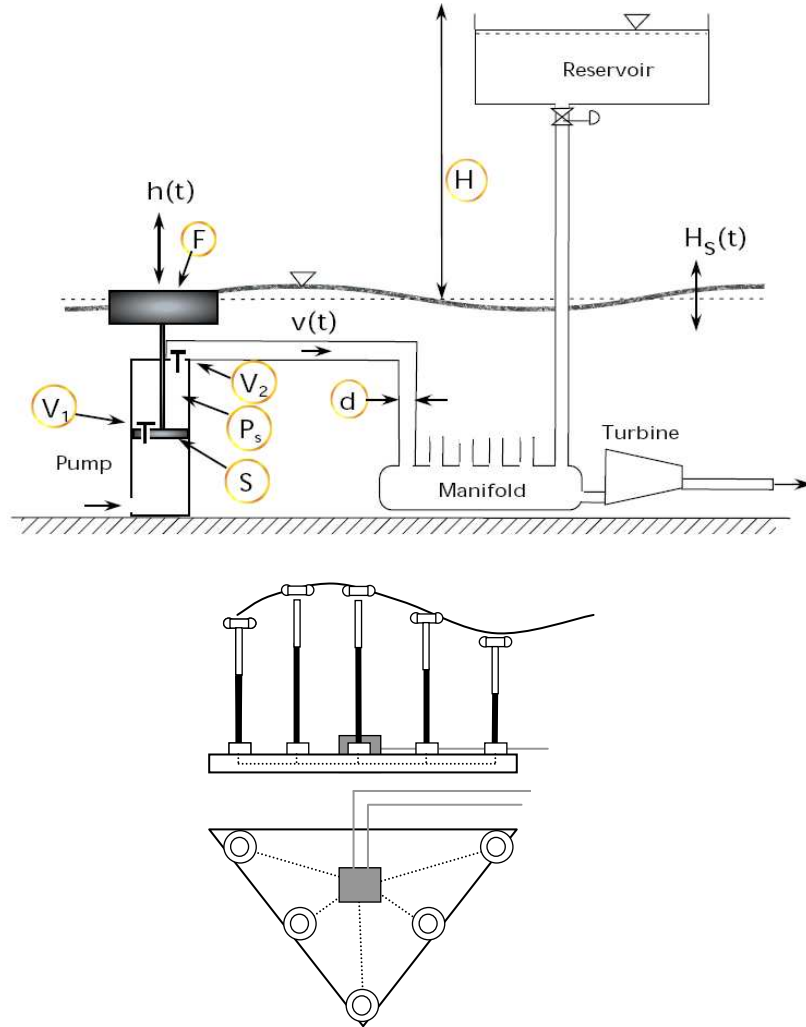

Fig. 1 Scheme of principle for the WAVEGEN prototype

1.2 Contractors list

Participant role	Participant type	Participant No.	Participant short name	Country	Date enter project	Date exit project
CO	RTD	1	LABOR	IT	Month 1	Month 28
CR	SMEP	2	IDEUT	NO	Month 1	Month 28
CR	SMEP	3	NORP	NO	Month 1	Month 28
CR	SMEP	5	PREP	NO	Month 1	Month 28

CR	SMEP	7	GEA	IT	Month 1	Month 28
CR	OTH	8	EEM	PT	Month 1	Month 28
CR	RTD	10	AREAM	PT	Month 1	Month 28
CR	OTH	11	ABS	NO	Month 1	Month 28
CR	RTD	12	TI	NO	Month 8	Month 28

Table 1– List of participants

*Project Coordinator:***Paolo De Stefanis**

LABOR Srl

Via Giacomo Peroni, 386 (c/o Tecnopolo Tiburtino)

00131 Roma (Italy)

Phone: +39 06 40040354

Fax: +39 06 40040357

Email: p.destefanis@labor-roma.it*Project Technical Coordinator:***Torger Tvester**

IDEUTVIKLING

2110 Sladstad (Norway)

Phone: +47 62967292

Fax: +47 62967172

Email: ideutvikling@netcom.no

1.3 Work performed

The work performed in the project was divided in the following Work-packages:

1) WP1 Alpha Layout

- a) Analysis and assessment of all possible configurations for the WAVEGEN prototype, producing more than single possible layout. This draft dimensioning and specification of the system will be used to produce the fluid dynamic model.

The outcome of this WP was the definition of:

- Alpha hydraulic layout
- Alpha electric layout
- Alpha mechanic layout

2) WP2 CFD Model

- a) Provide a simulation model of the WAVEGEN system, including a cluster of Wave Pumps and a submerged water turbine
- b) Implement the model in the FLUENT CFD code; the model will be parametrical, so that its geometrical properties and energy input can be changed.

The outcome of this WP was the Fluid Dynamic Simulation available for the Optimization by Experimental Design of the critical parameters of the system.

3) WP3 Optimization

- a) Achievement of an optimised configuration of the WAVEGEN system
- b) Maximisation of energy conversion
- c) Minimisation of mechanical stresses over the structure

4) WP4 Executive design

- a) To provide all the necessary documentation to start the prototyping phase
- b) Information about materials to be used, the accessories, the assembling procedures, the welding requirements
- c) Design and specifications of the WAVEPUMPS and the turbine
- d) Final design of the anchoring system
- e) Final electric design

5) WP5 Prototype manufacturing

- a) Pumps prototyping – manufacturing of 5 WAVEPUMPS and all necessary polyethylene pipes and connections;
- b) Turbine manufacturing – manufacturing of one prototype sub-sea turbine, including power conditioning devices.
- c) Accessories prototyping – manufacturing of the remaining metal and concrete parts for anchoring and fixation;
- d) Integration of components

6) WP6 Testing and optimisation

- a) Prototype deployment – system deployment in its testing area;
- b) Testing – the prototype will be tested during 5 months, and its performance will be continuously monitored;

7) WP7 Assessment of results

- a) Reporting on test results – data acquired will be analysed, extracting meaningful indicators. These will be used also to study and assess what synergies can be implemented between the WAVEGEN technology and wind energy parks.
- b) Technical/economical assessment – the analytical results, together with economic indicators resulting from the previous prototyping and deploying activities, will be used to provide an overall technical and economical assessment of the system.

8) WP8 Exploitation and dissemination

- a) Exploitation strategy was defined:
 - The marketing strategy was defined
 - Routes for future research and development activities were outlined
- b) The dissemination measures carried out in the second year of the project include:
 - Several fairs, workshops and meetings
 - A Web page for the dissemination of the aims and results to the wide public
 - Contacts with potential customers

1.4 Final results

The main results achieved by the Wavegen project are described in the following sections:

1.4.1 WAVEGEN specifications and design

The main specifications identified for the WAVEGEN system are the following.

- 100 kW offshore submerged wave energy converter
- Linear array made of 5 WAVEPUMP units made of standard polyethylene pipes, each approximately of the following size:
 - buoy diameter 3 m
 - buoy height 1 m
 - pump cylinder diameter 0.7 m, length 6 m
- Piston rod diameter 0.2 m, length 15 m Pumps producing flow in a main pipe leading to the sub-sea energy converter, all installed in a common anchoring platform.
- The total length of the platform is defined by half a wavelength - 15 to 20 meter.
- The distance between the pumps eliminates pulsation in the main pipe leading to the energy converter.
- Installation depth around 20 meter.
- The 5 pumps will deliver 350 l/sec at 4 kg pressure (100 kw) when working in the average wave regime at Madeira
- Pumps producing flow in a main pipe leading to the sub-sea energy converter, all installed in a common anchoring platform

These specifications led to the following layout for the three Wavegen' subsystems:

- 1) Hydraulic system
- 2) Mechanical system
- 3) Electrical system

1.4.1.1 Hydraulic system

According to the recommendations coming from the CFD analysis, the simulations and AREAM's calculations, the final layout of the system was sketched. This includes the CAD design of the entire system, with all the relevant materials accurately selected. The final version of the prototype can be seen in the following pictures:

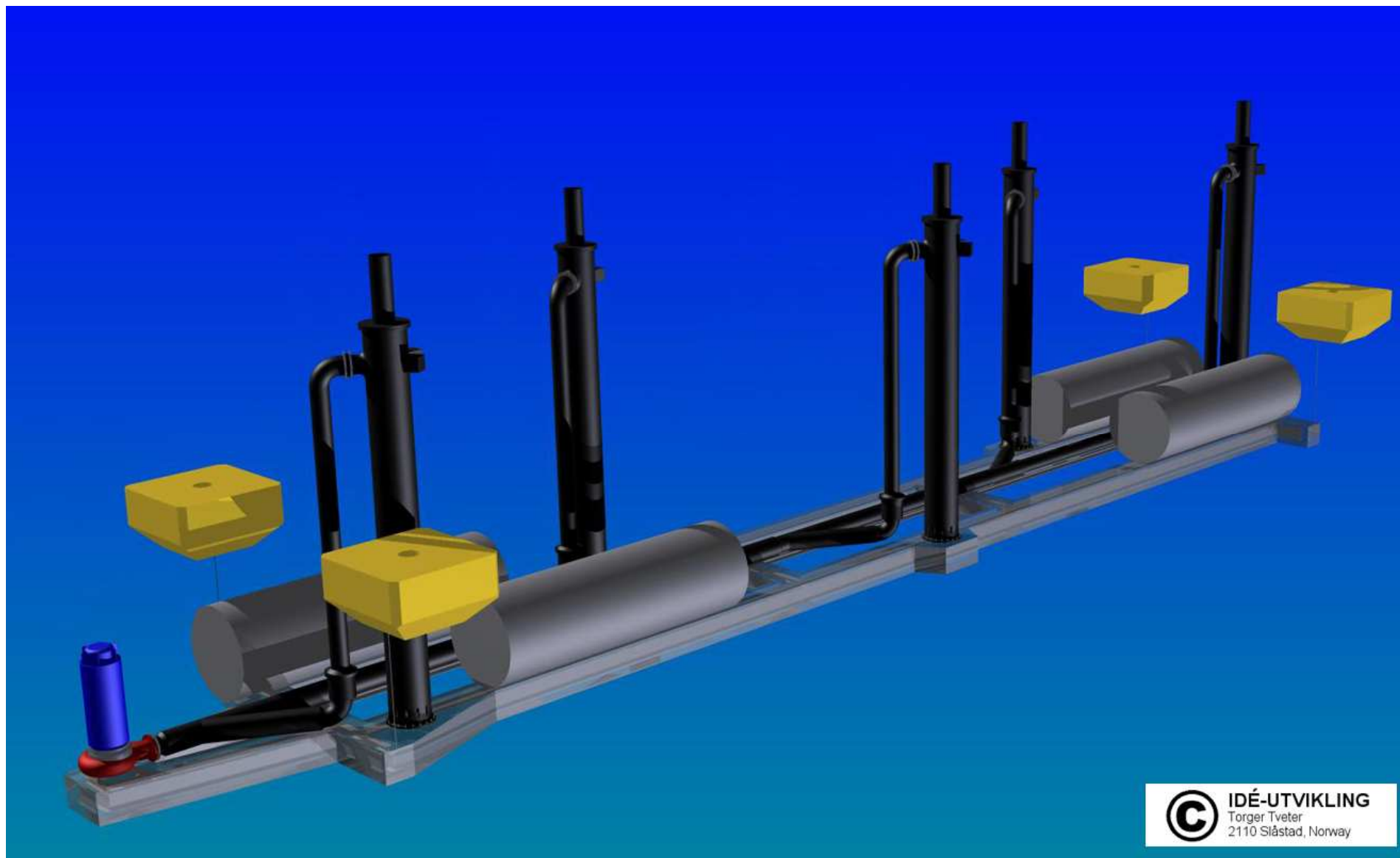

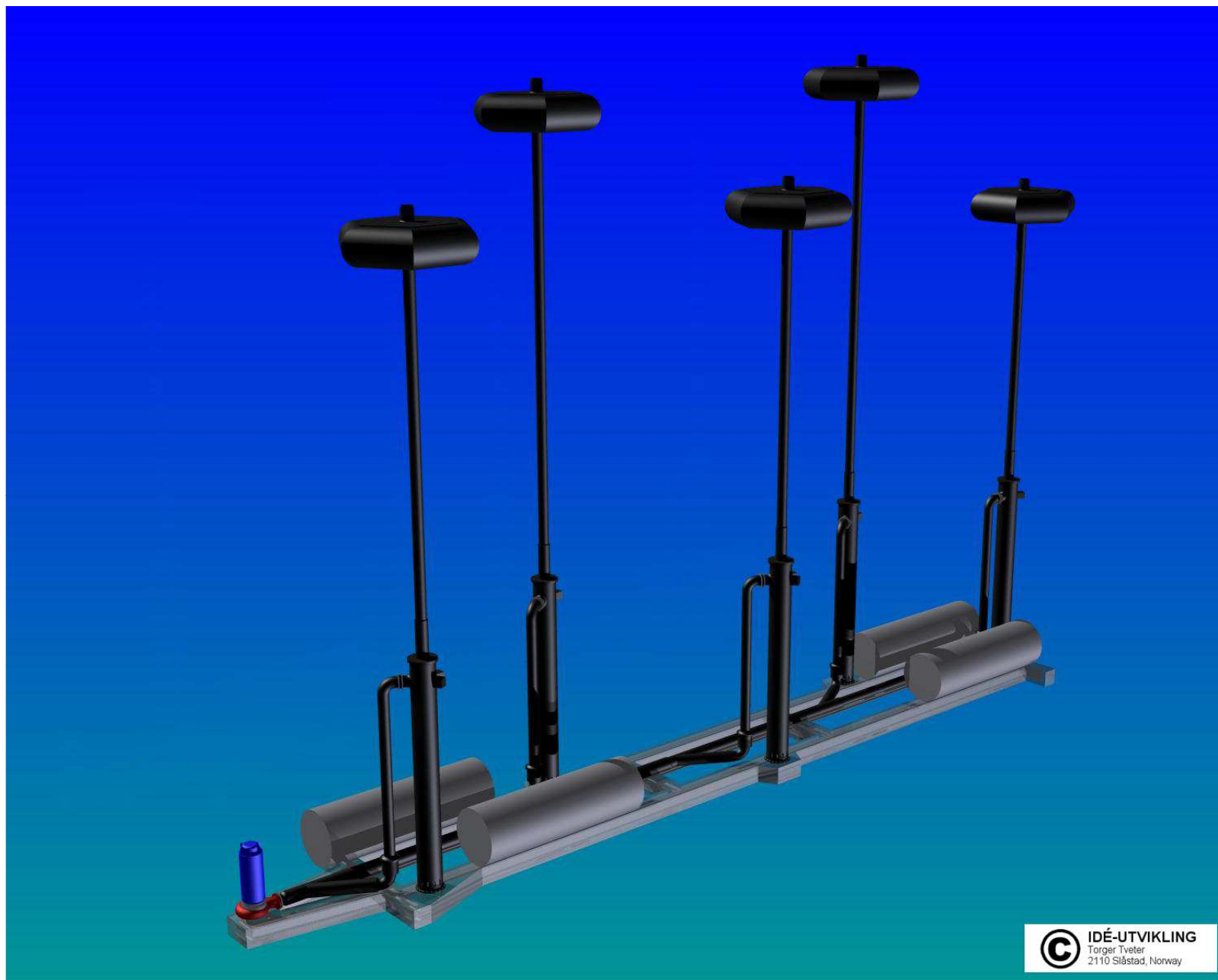

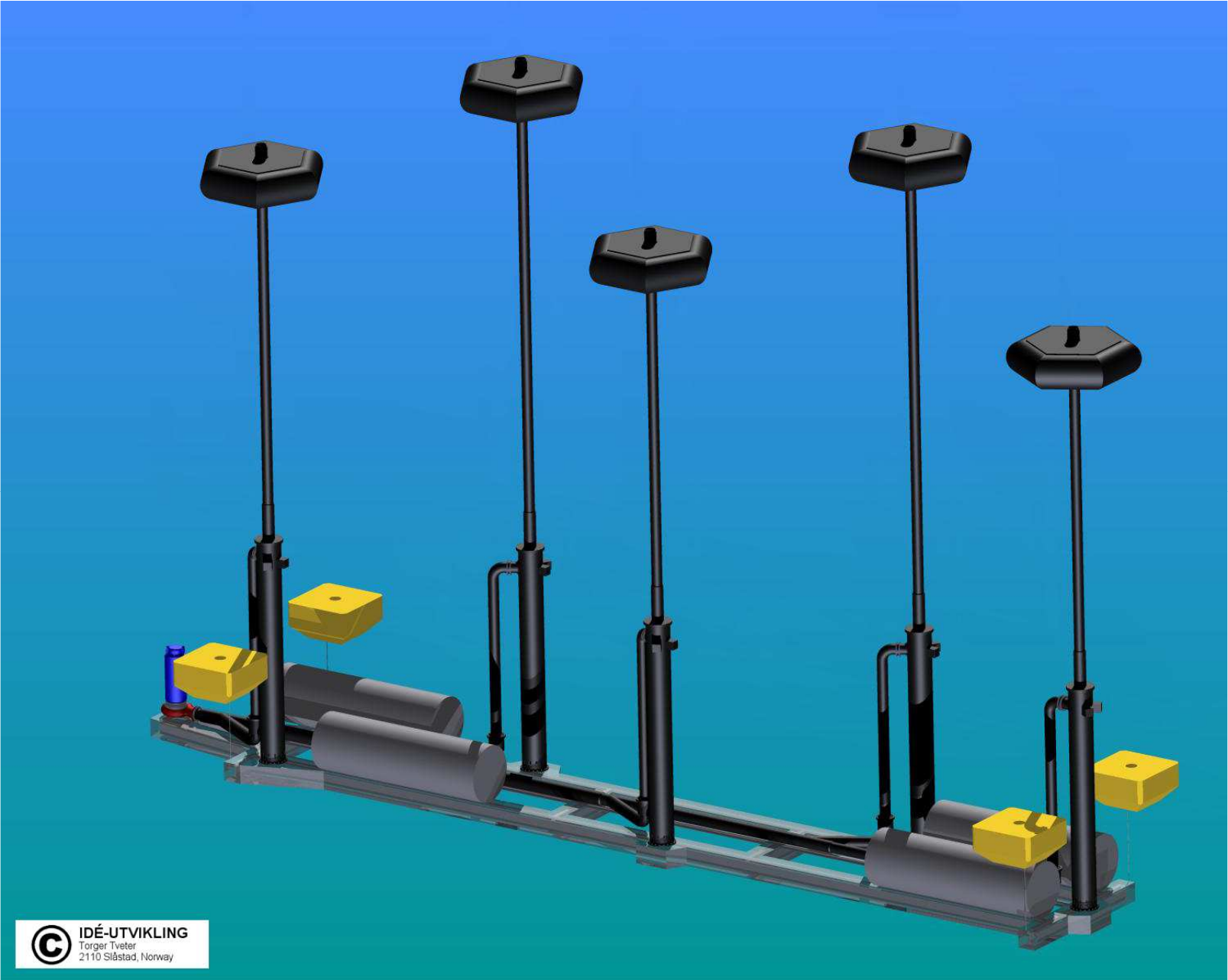

1.4.1.2 Mechanical system

As for the mechanical layout of the anchoring system and the buoys, the calculations made available by AREAM helped the optimization of both the structures, leading to the realization of the final prototypes that will be described in the following section dedicated to the deployment of the overall system.

1.4.1.3 Electrical system

As for the electrical design, the final specifications have been produced by GEA, describing the static converter system to connect an asynchronous generator with $P=100$ kW to the mains.

The main assumptions considered in designing the system were:

- Unsteady power delivering from the turbine
- The need to avoid that the turbine operates in “pumping mode”, thus causing troubles to the wave-pumps and to the turbine itself.
- The need to connect the turbine to a load to drive away the power in case of a failure in the main power line, thus preventing turbine damaging

This being said, it was decided to adopt a solution with an asynchronous motor connected to the power line by means of an inverter (see the attached scheme), that will also:

- Prevent the undesired flow of energy from the power net back to the turbine
- Provide energy to the net with the foreseen wave form and frequency, nonetheless the unsteady power production of the turbine
- Drive the asynchronous generator
- Provide energy to the net according to the regulations
- Grant the necessary protection of the line, monitoring and regulating the variations of frequency and voltage

The power line failure is managed by driving the power coming out from the turbine to a resistive load, trimmed according to the instantaneous energy production, to avoid the over speed of the turbine

It is at the same time recommended to foresee the possibility to stop the water immission to the turbine to avoid the over speed and to allow maintenance.

A) Equipment list of the supply proposal

A1) 1 Metallic cabinet containing a 100 kW 400 Vca static converter system for asynchronous generator complete of 100 kW brake resistor

B) Generators electrical features

B1) asynchronous generator :

Supplier:	SICEI
Type:	ME1100/4-54
Rated Power:	100 kW
Rated speed:	1500 rpm
Rated current:	180 A
Rated voltage:	400 V
N° poles:	4

C) General features

Mains voltage:	three-phase 400 V + 10%
Mains frequency:	50 Hz + 5%
Ambient temperature:	5°C +50°C
Aux. circuit voltage:	110 V 50 Hz
Signal. circuit feeding voltage:	24 Vdc
Altitude:	<100 a.s.l.
Installaton :	in ventilated room, clean air, no aggressive agents
Max humidity:	95% at 20 °C

D) Manufacturing general features

All the equipment supplied from shell comply with:

1. Council directive n° 73/23/EEC dated 19/02/1973 (Low Voltage)
2. Council directive n° 93/68/EEC dated 22/07/1993 (CE Marking)

In designing and manufacturing of the electronic equipment shall be applied the following norms:

- CEI EN 60204-1: Machinery safety . Electrical equipment of the machines. Part 1: general rules
- CEI EN 61800-2: variable speed drive system Part 2: general requirements and nominal specification for low voltage drive systems for alternate current motors
- CEI EN 61800-3: variable speed drive system Part 3: product norm concerning the electromagnetic compatibility and specific test methods

E) Main components suggested suppliers

Ac/dc converter :	E.E.I. - Italy
Inverter :	E.E.I. - Italy
Circuit breakers, isolators, contactors:	Siemens, ABB SACE and similar
IGBT, Diodes:	Mitsubishi, Eupec, Toshiba, Semikron
Integrated circuits and the other electronic components:	best known suppliers

F) Detailed description of the supply

G1) 1 Static converter system for asynchronous generator 100 kW 400 Vca

Mains voltage:	400 V – 50 Hz
----------------	---------------

Converter power:	100 kW
Output rated voltage:	400 V
Output rated current:	150 A
Efficiency :	95 % at 100% power Inverter control digital
Inverter regulation :	PWM Converter
Overall dimensions:	H 2200 W 1000 D 1000

Colour RAL 7032 epoxy powder or in compliance with request

The static converter system is contained into a metallic cabinet with one door with fan and filter;
mechanical protection degree: IP 20 or superior

G2) Resistor

The overall dimensions of the resistor cabinet are:	(mm) H 1600 W 800 D 800
The total dimensions of the system (converter):	(mm) H 2200 W 1000 D 1000
The total dimensions of the system (resistor):	(mm) H 1600 W 800 D 800

Front of the converter cabinet

On the front of the cabinet the following devices are provided:

- Mains circuit breaker
- Aluminium panel with:
 - Start, stop push buttons
 - Emergency stop push buttons
 - reset
 -
 - LCD video keyboard to set-up the inverter
- Transformers for aux services 400/110 V
- 1 auxiliary relay set
- Auxiliary feeder 400 Vca/ 24 Vcc
- Automatic circuit breakers for auxiliary devices
- Terminal boards for power connections
- Terminal boards for auxiliary connections

The brake resistor is sized to dissipate 100 kW continuously in case of mains lack.

The system is able to avoid the running as a motor and it is able to operate with variable power and frequency.

G) Electrical general layout

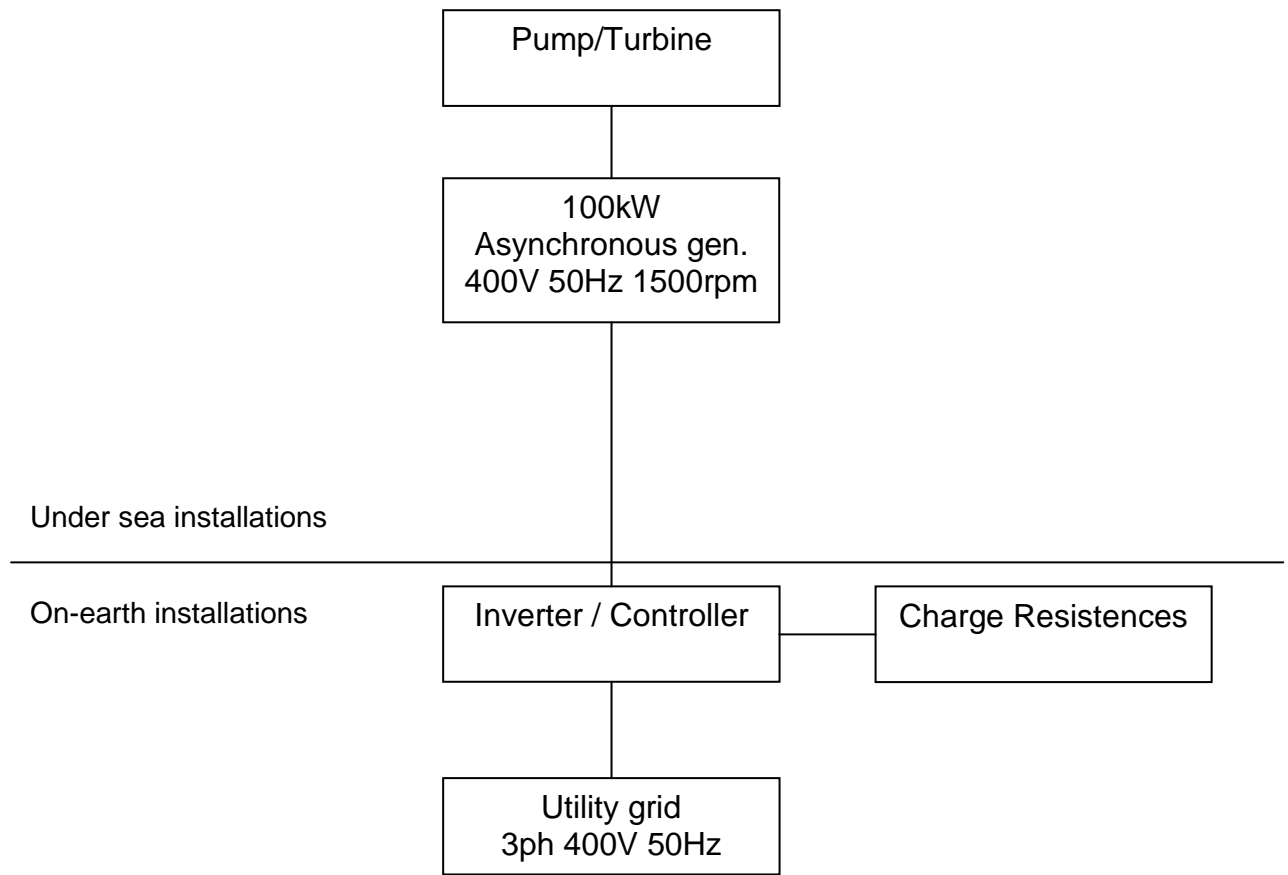

The turbine was produced by ABS, with the dimension drawing and the characteristic curve shown in the next figures.

	AFP 2501	No: M-02.0197 - 08
	Dimension sheet M6-M7 DRY-WELL Installation	Dat/Nam.: 09.03.05/ T.Seidlitz
	Maßblatt M6-M7 Trockeninstallation	Cad Code: M_020197
	Plan d'encombrement M6-M7 installation fosse sèche	Technical changes reserved Änderungen vorbehalten ABS se réserve le droit de changer ses caractéristiques techniques

Type Typ Tipo	Type Typ Tipo	Weight Gewicht Poids	Weight Gewicht Poids	H	H
50 Hz	60 Hz	(-kg)	(-lbs)	(mm)	(inch)
M1320/4-62	M1500/4-62.60	1710	3771	1845	72.6
M1600/4-63	M1850/4-63.60	1810	3991	1965	77.4
M2000/4-71	M2200/4-71.60	2040	4498	2125	83.7
M2500/4-72	M2800/4-72.60	2070	4564	2125	83.7

Weight: Includes pump and pump stool
 Gewicht: Beinhaltet Pumpe und Pumpenständer
 Poids: Pompe et socle

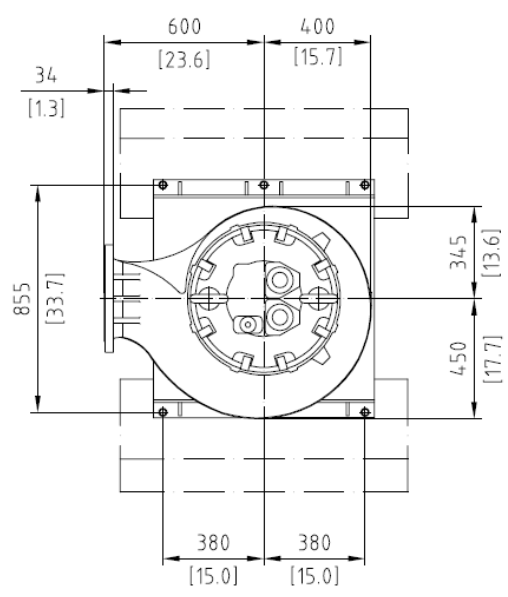
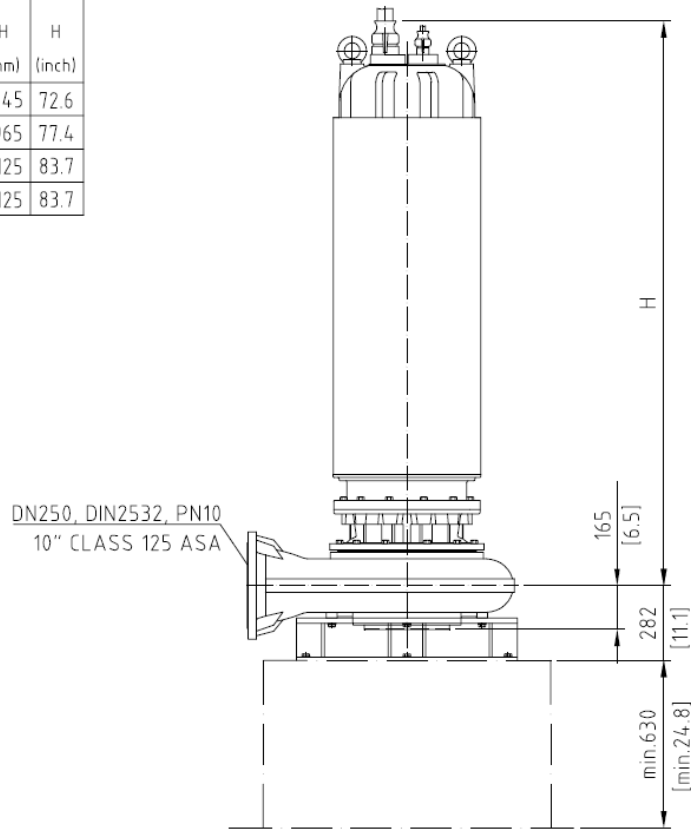

[mm]
[inch]

Connection details acc. to drw. AN-M.02.0351
 Anschlußdetails nach Blatt AN-M.02.0351

Dimensions of C.I. 90° bend on request
 Abmessungen für Guß-90° Bogen auf Anfrage
 Dimension pour coude fonte 90° disponible sur demande

Foundation in acc. to drawing AN-20.001
 Fundament nach Plan AN-20.001
 Fondation selon schéma AN-20.001

**Turbindata för AFP2501ME104/8-1175rpm
Dy 446mm - 350l/s(1260m³/h) x 40m fall**

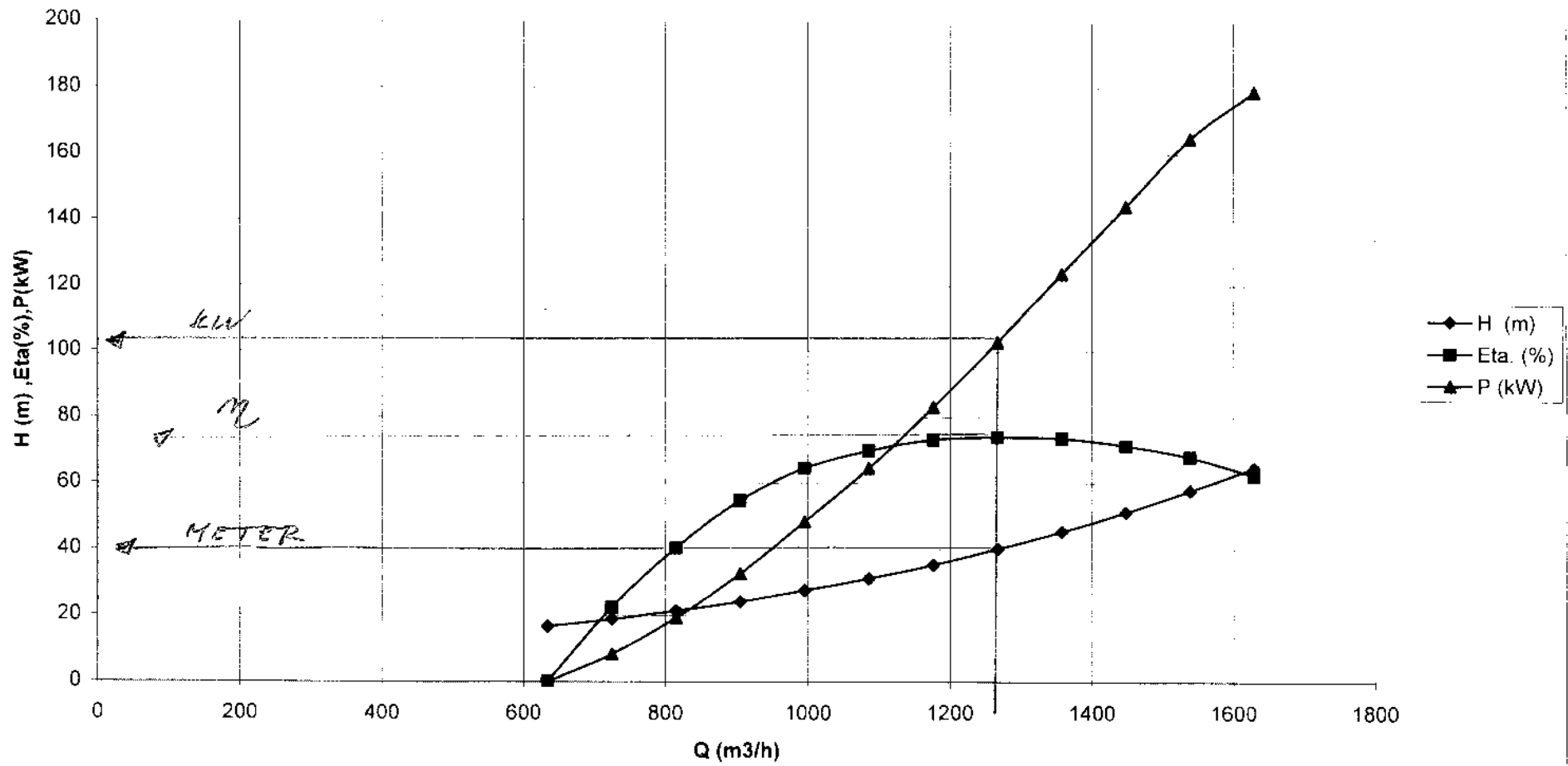

Max. flow:

50 Hz: 1,000 l/s (15,852 USgpm)

60 Hz: 1,200 l/s (19,022 USgpm)

Max. head:

50 Hz: 76 m (249 ft)

60 Hz: 90 m (295 ft)

The AFP converter has the capacity to adapt to different flow and pressures from the wave pumps. However the varying production from the pumps will represent some loss in efficiency.

To secure the most optimal efficiency from the AFP, we will install a pipe connection to a land based tank or basin, installed on the level (ca 40 m) of the optimal pressure for the AFP.

This connection with the basin represents a reservoir as well as a pressure regulator.

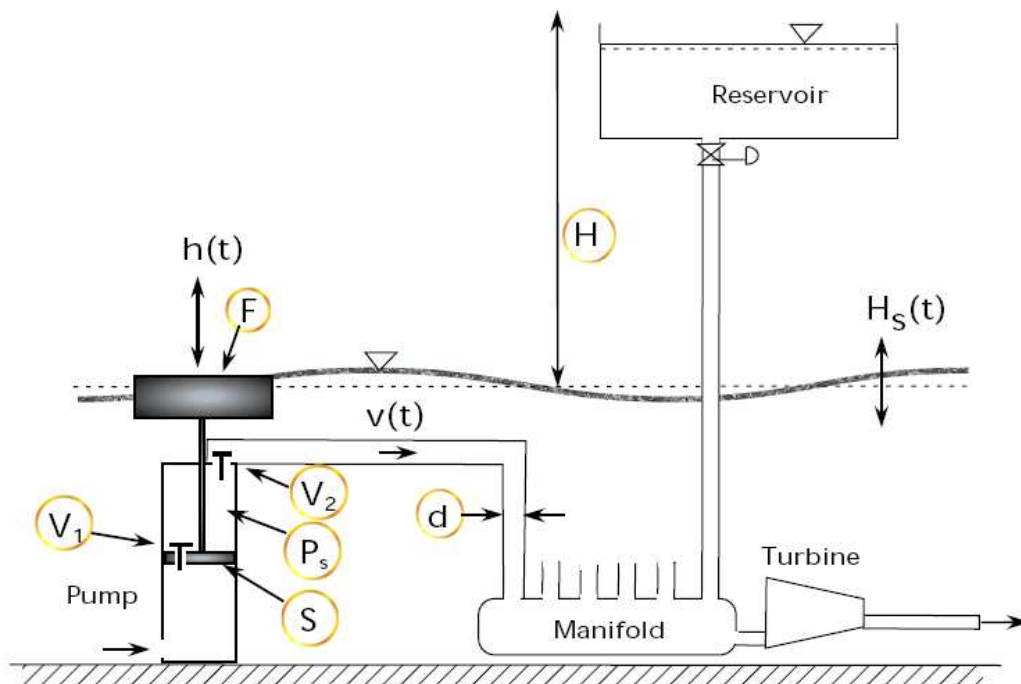

1.4.2 CFD analysis and simulations

The composite model of the WAVEGEN system is constructed for a single plant configuration. Energy optimisation is performed by calculating the generated power energy of the plant on a typical one year for a single configuration.

Finally, computer power is used to simulate different configurations and a rough optimisation is done. The annual average energy (AAE) is used to compare the performance of the different plant structures. The best configuration is found by obtaining the average annual energy produced by each configuration.

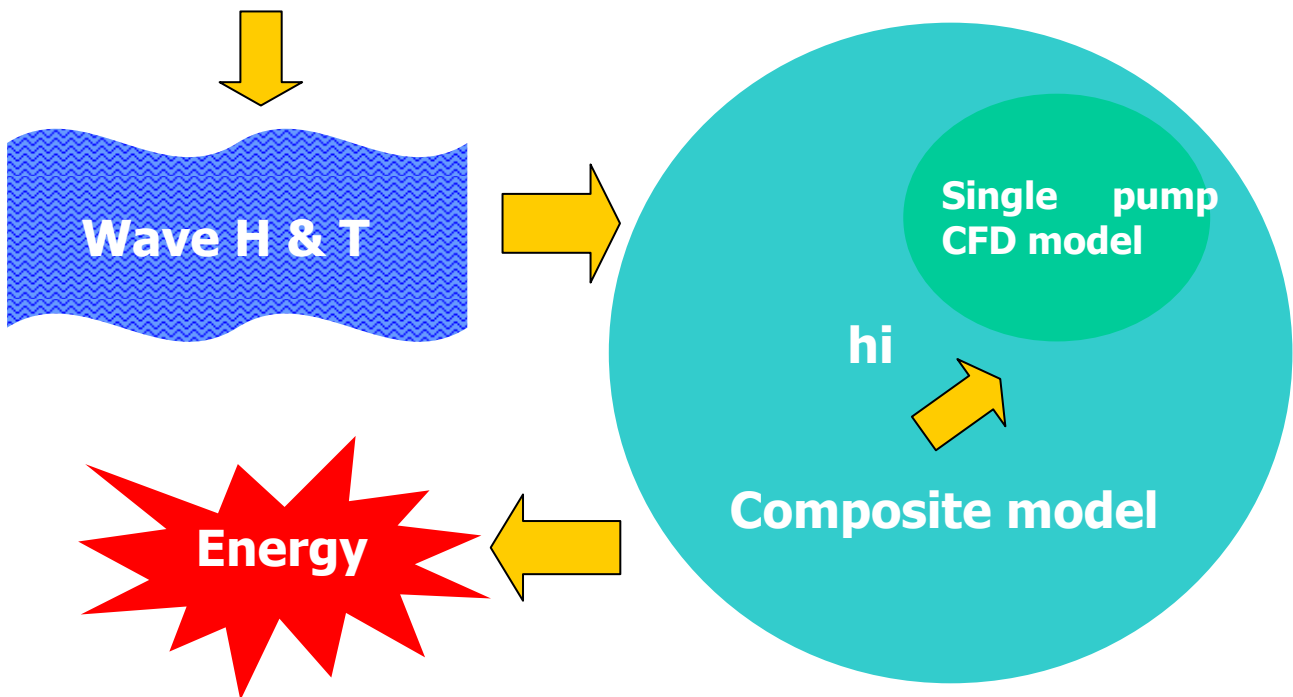

Figure 2 Methodology used for generated power calculation of a single plant configuration

Wave characterization

Monthly statistical data is used to generate hour per hour wave height and wave period.

Normal monthly distribution is assumed. For the given location minimal and maximal experimental values are the limits set for data generation. Hour by hour wave height and period are randomly generated. The results of a typical year are presented on figure 3.

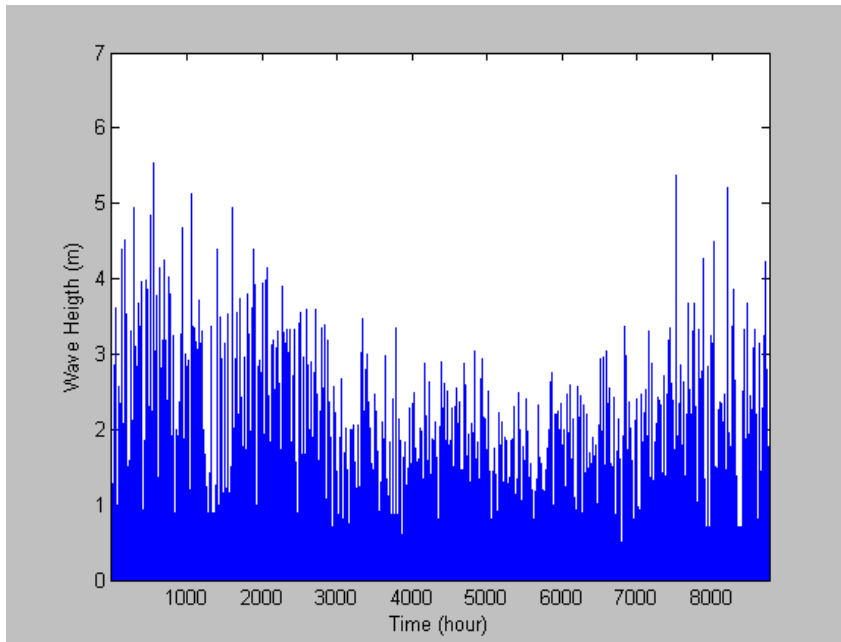

Figure 3 Data of one year wave height simulation

These data have a mean of 2.23 m with a minimum value of 0.5 m and a maximum value of 6.91 m. These statistical descriptors are the same as the statistical descriptors of San Vicente, Madeiras.

In a similar way, wave period is obtained. On figure 3 one year is represented. These data present a mean of 8.25 s with a minimum of 5.1 s and 15.39 s maximum wave period. These statistical descriptors are the same as the statistical descriptors of the wave period at San Vicente Madeiras. It should be noted, however, that wave period and wave height data are not correlated. This is a matter of further work and methodology improvement.

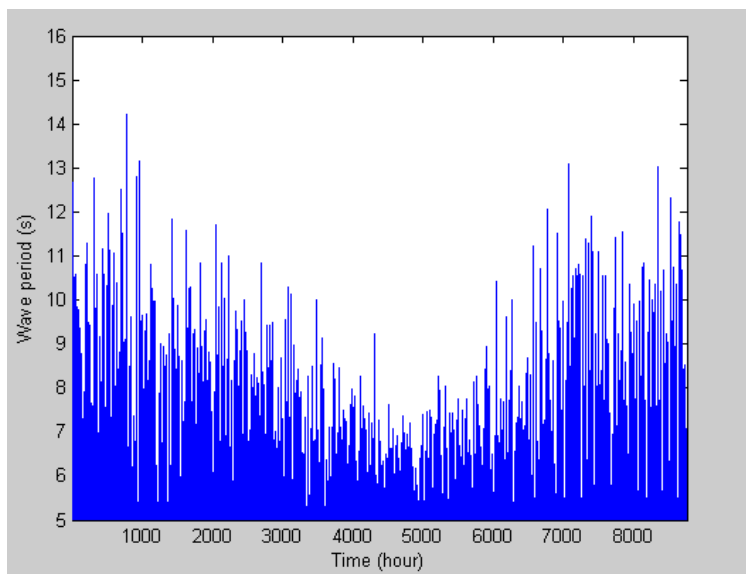

Figure 4 Data of one year wave period simulation

Composite model of the power generation plant

Fluid dynamic model of a single pump was developed by TI. The phenomenological equations were solved however using Mathworks MATLAB. In this way the fluid dynamic simulation of a single pump could be easily incorporated on the overall system simulation.

The composite model incorporates the functional relationship with pump site, dependence of number of pumps, dependence with pipe length and gives the overall power energy produced. However to facilitate results analysis a fixed set of parameters were used:

- Float characteristics
- Pipes and reservoir sizes
- Turbine behaviour

a) Circle plant configuration

Two different plant configurations were studied: Circle and line. On a circle configuration, the turbine collector is placed on the centre of the pumps. The distance of each pump to the collector is given by a fixed dimension, the radius. The number of pumps define the distance between them. An scheme of this plant configuration is presented on figure 5. The optimization parameters for this configuration are the number of pumps (NN) and the radius (r), by using these two parameters the pumps location are defined.

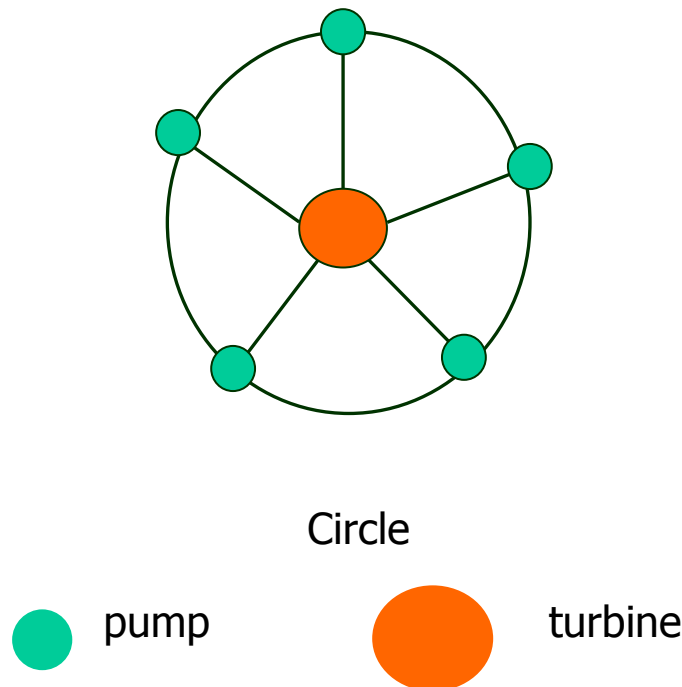

Figure 5 Scheme of the circle configuration of the power plant

b) Line plant configuration

It was convenient to study a second plant configuration to determine if plant geometry is a decisive factor that affects the overall power generation. This second configuration is on practice of easier realization. The optimization parameters are the number of pumps (NN) and the total pipe length. The main difference between both configuration programs is the relative distance between pumps.

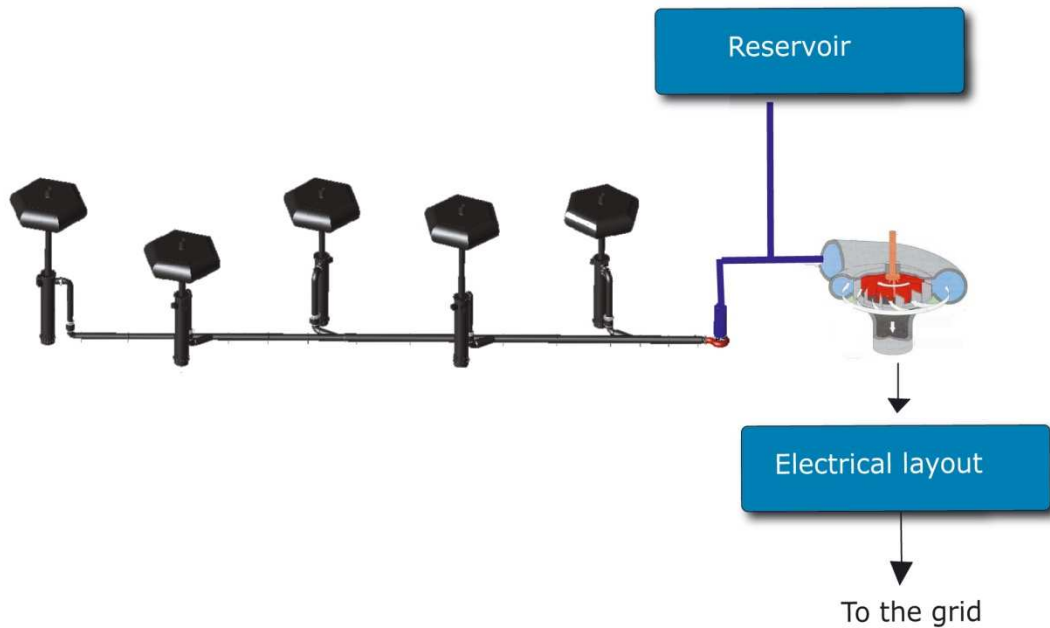

Figure 6 Scheme of the line configuration of the power plant

Results

The solution of the above optimization problem is very complex. A first series of simulations were performed to define the computer time involved in simulation. It was found that each call to single pump takes 4.145 s on a Pentium 4 3.2 GHz. The calculation of the generated power for a given geometry (defined number of pumps and defined pipe length) in a whole year takes in average 10.01 hours to run. Results for a circle configuration using a pipe length of 10 m are presented on figure 7. It could be seen that the power generated increases if the number of pumps is increased.

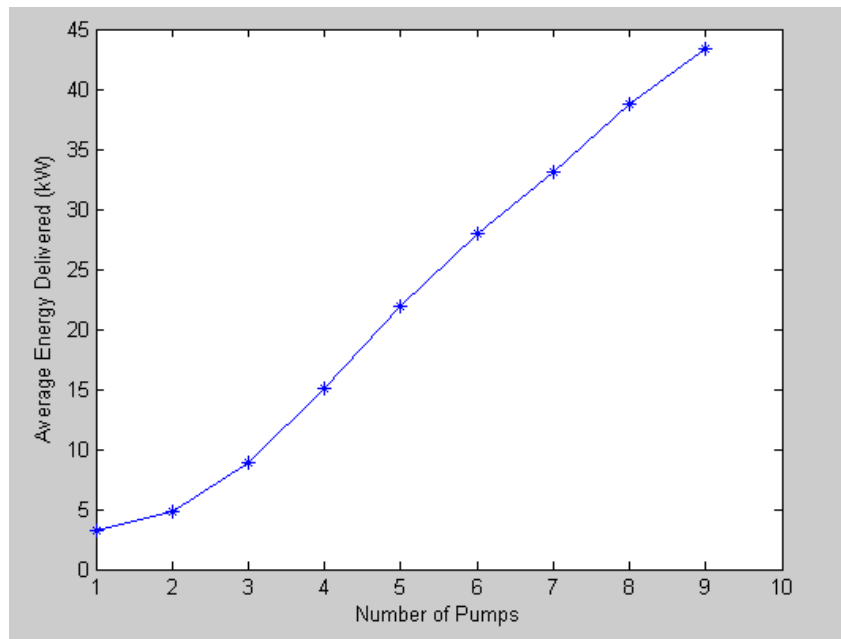

Figure 7 Average Energy delivered for a circle configuration of 10 m pipe length

On figure 8 the annual average energy of both configurations is present. For the line configuration the delivered energy also increases as the number of pumps is higher. However for the same number of pumps the generated energy is higher on the line configuration.

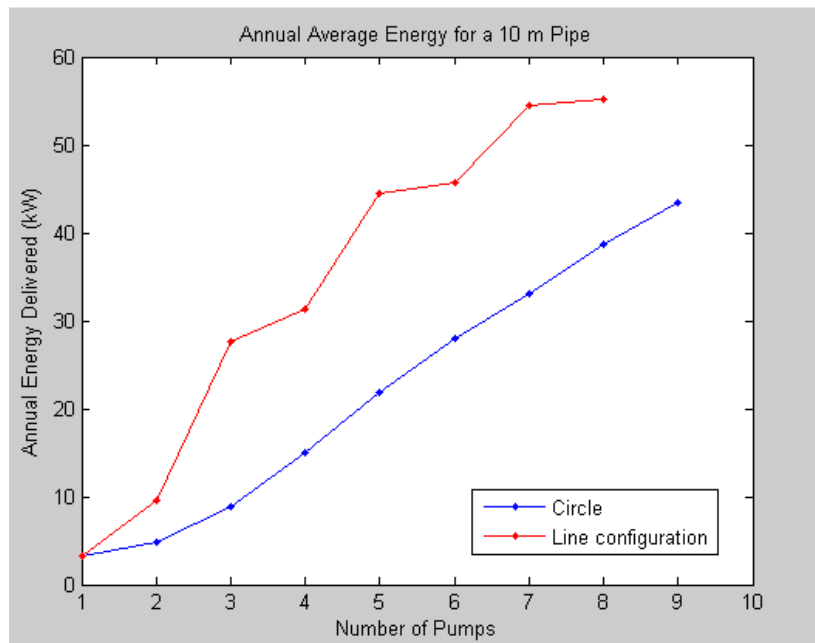

Figure 8 Annual average Energy delivered for a 10 m pipe length

Considering the computer time required by each simulation and in view of these results, a series of tests were performed in order to find the optimal plant configuration into a specific and realizable range. The

maximum pipe length allowed was 40 m, and the maximum number of pumps was 8. Line configuration was chosen. Results of these tests are present on figure 9.

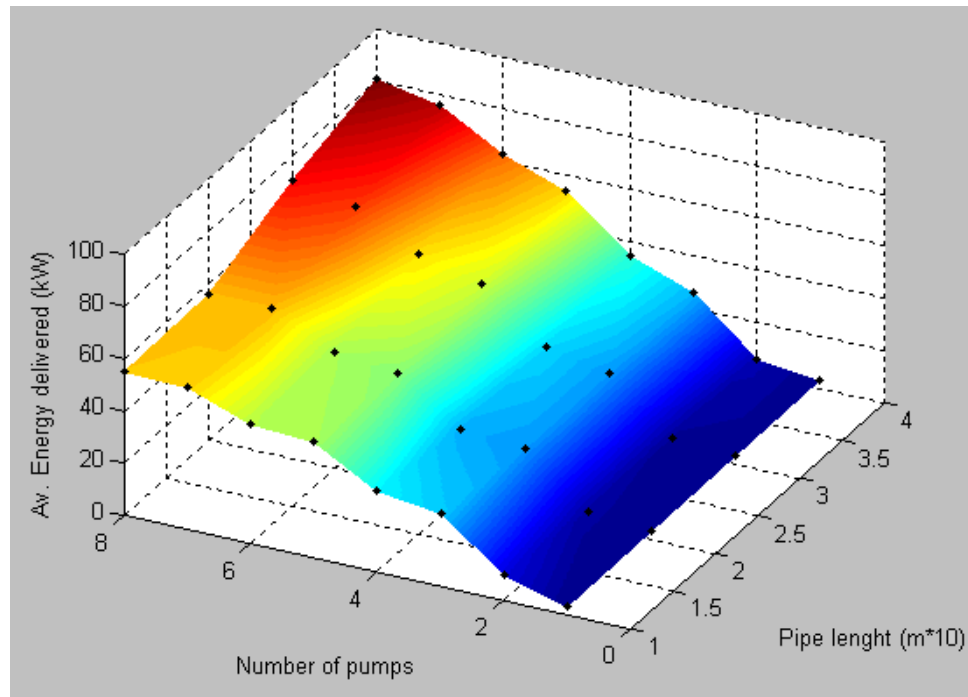

Figure 9 Average annual Energy delivered for different structures of a plant with line layout

As it was expected it can be seen from the figure that as increasing the number of pumps the AAE increases also. Besides, the AAE increases with the pipe length. Because is not feasible to use higher pipe dimensions our problem is constrained by technical specifications. For instance for an actual pipe length of 30 m the maximum AAE is obtained using 8 pumps. Other operational variables such as pressure should be also considered when defining the optimal geometry of the WAVEGEN system. The expected values of some of those variables are also given on the composite model program. For this plant the calculated pressure is presented on figure 10 and 11.

It can be seen that the average pressure is around 400 kPa but it presents peaks as higher as 1000 kPa. These high pressure values constraint the plant design more than the geometrical layout.

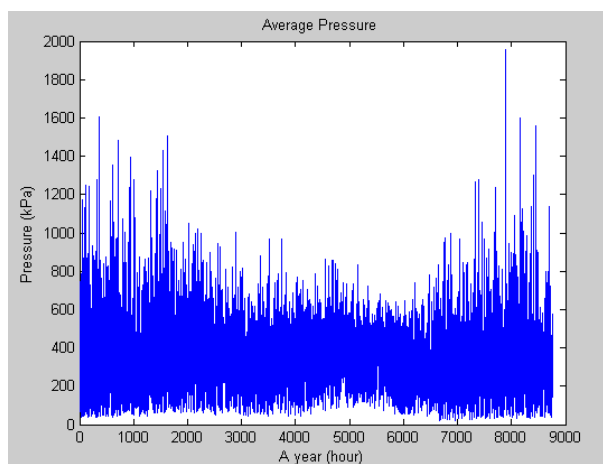

Figure 10 Average pressure on a power plant with line configuration for 8 pumps and 30 m length pipe

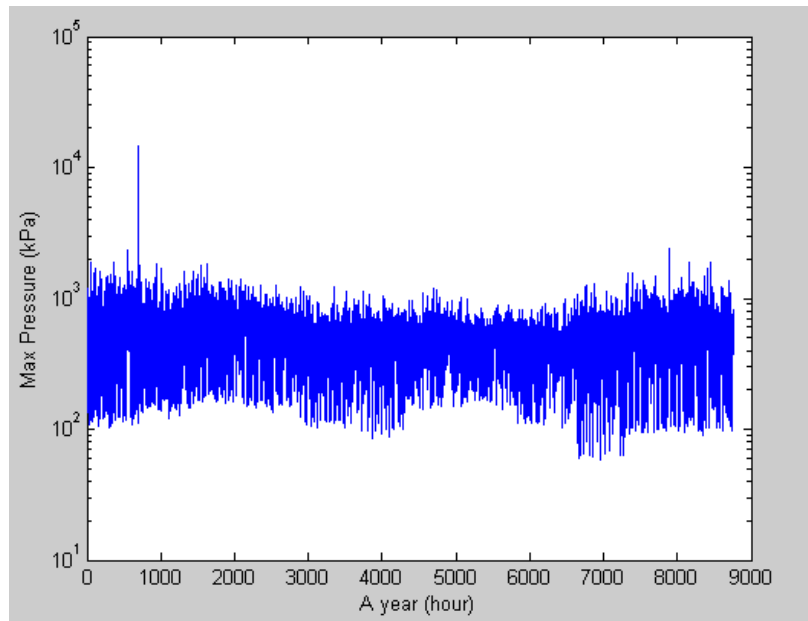

Figure 111 Maximum pressure present on a power plant with line configuration for 8 pumps and 30 m length pipe

The conclusion of this first set of experiments is that the average annual energy (AAE) delivered increases with the number of pumps. Distance between pumps also results in AAE increment. It was found that other variables should be taken into account when designed the system (i.e. pressure) because define the plant realization constrains. Sea deployment requirements will influence system configuration more than energy optimization results. Further work could refine optimization results. WAVESIM program could be further improved with CFD equations, mainly to describe the manifold section, the flow through pipes and the interaction of different pumps.

SECOND SET OF EXPERIMENTS

In the first set of simulations a number of simplifications were made that affects the true estimated power output. In this second set of experiments we document the effect of removing two of these simplifications. The first is that the piston movement will have a finite limit due to the finite length of the pump cylinder. The upper and lower limits will vary as the water level rises and falls with the tide. Also, even perfect sinusoidal waves will not cause perfect sinusoidal float movements due to the way the pump is constructed and as will be shown there is a tendency for the float to sink deeper below the neutral point than the amount it rises. Therefore it is important to include the effects of limited vertical movement in the estimates of the output power. Another design fact that has been given much attention during the Wavegen project meetings is the possibility to protect the float and piston rod from overloads by letting

the float dive into the waves when these become excessive. The method used to obtain this effect was to give the float limited buoyancy. Since the float spends more time below its neutral point than above, a float with limited buoyancy will automatically sink to a lower level when the wave height increases, causing the float to be submerged for a longer period of the wave as the wave height increases. Hence the load is reduced, but this will also reduce the power output as the float has a limit to the vertical force it may generate. This restriction was not included in the original Wavesim program and the present report documents the effect it has on the power generated. The mathematical details of this new model are shown in Deliverable D4, while the modifications of the model are that the cylinders are 6m long and the piston has a free travel length of about 5m. If the piston reaches one of the end stops, irrespective of whether it is the upper or lower end, it will be stuck here until the pressure build-up over the turbine generated from the other pumps is reduced sufficiently for the gravity or buoyancy to overcome the piston force. This effect has now been included in the program. In the first version of the program it was assumed that the float height was unlimited, so that the buoyancy force was always proportional to the difference between the water surface elevation and the height of the float neutral point, $(H_s - h)$. As mentioned above, in the final version of the design the float is intentionally made to dive if the waves are too high. When this happens the buoyancy force no longer depends on the height difference, but is restricted to the float depth, L , minus the amount it sinks into the water to the neutral point, y_0 . In this case the modeled normalized buoyancy term, $b \cdot (H_s - h)$ becomes a constant which slightly changes the equation solution strategy. This is now included in the program.

To illustrate the effects of finite piston stroke and limited float volume, a number of simulations have been presented in Deliverable 4 to show how this affects the primary results such as the energy produced etc. So, the final outcome of the simulations for a typical wave pump set-up include the important real life effects of final piston movement length and buoyancy which was not included in the original simulation program. As demonstrated by the sample calculations presented for a randomly selected sets of waves both effects seriously reduce the power output from the wave power plant. The power generated depends more or less linearly on the piston free travel when this starts to be restricted by the finite length of the pump. It is therefore quite important to make the pumps of sufficient length to avoid restrictions until the waves are significantly higher than the wave height the plant is designed for. The idea of restricting the hydrodynamics loads on the power plant by limiting the volume of the float in such a way that it starts to dive into the waves rather than floating on the surface is a very good concept from a structural point of view, but has severe implications on the power produced. In the present calculations, when the float volume is reduced to the size of the pump volume, the power generated was found to have been reduced by a factor of the order of 200. Although this factor will depend strongly on the pump piston diameter the calculations clearly demonstrate that the protection of the pump implies a severe sacrifice in plant

efficiency. Therefore it is very important to choose the pump dimensions and float volume so that no restrictions occur during operation for the target wave height.

HORIZONTAL FORCES CALCULATION

Another fundamental contribution for the definition of the final layout come from AREAM, who performed a thorough calculation of the horizontal forces acting on the wavepumps, aiming to determine the best configuration of the system in order to reduce the risk of structural breakdown.

In order to model the movement of the fluid particles in a wave, basically two approaches may be used. In the first approach, a given point is set in space and the variations of the velocity and acceleration of the particles are verified at that point along time – corresponds to taking a succession of photographs of the wave from a fixed point (Eulerian representation). In the second approach, a given particle is marked and its movement in space is followed – corresponds to a film of the course of the observed particle (Lagrangian representation). The result of this phase was the calculation of the total maximum horizontal force and the momentum, which will be attenuated in real conditions due to the deformation of the cylinder. However, in the other hand, as the buoy is be submersed at the wave crest ($t = 0, T, 2T, \dots nT$), the force and the momentum will have an additional contribution from the horizontal forces applied to the buoy. The increased diameter of the lower element of the wavepump cylinder has a negligible contribution, since the horizontal velocity of the water is very low. In average wave conditions, the expected maximum horizontal force for each wavepump is 1 361 N (139 kgf) and the maximum momentum is 17 193 N.m (1 754 kgf.m). In this case, the deformation of the cylinder will absorb most of the forces applied, because the maximum horizontal displacement of the water particles is 1,3 meters. As the wave length is 92 meters in this case, the wavepumps of the system should be in different phases of the same wave and the forces in the structure are not coincident. In this case, the forces and momentum can be supported by the bottom structure.

Under extreme conditions, the maximum horizontal forces and the momentum increases significantly. For each wavepump, the expected maximum horizontal force is 30 086 N (3 070 kgf) and the maximum momentum is 314 789 Nm (32 121 kgfN). The maximum horizontal displacement of the water particles is 9,7 meters (about 30 degrees from the vertical). In this case, the force absorption caused by the cylinder deformation is lower and the forces and momentum applied on the bottom structure is extremely high. Furthermore, as the wave length is 236 meters, the forces in the different wavepumps will be partly summed in the bottom structure.

Even if the calculations are a rough approximation of the real situation, where the forces and behaviour of the materials are very complex to compute by theoretical means, these calculations gives an idea about the

survival of the structure. The main measures identified to reduce these forces and the momentums are to shrink the diameter of the cylinder and to decrease its rigidity (for instance a cable) to facilitate the deformation and the momentum applied to the bottom structure.

1.4.3 System prototyping and installation

During this task, a set of 5 wavepumps has been realised in Norway. It was decided to deploy 5 pumps with cylinder length (stroke) of 6m, constructed in a 630mm PN 4 standard polyethylene pipe. The inner cylinder diameter represents 580 mm. For the piston rods, it was decided a 280 mm PN6 polyethylene pipe. This rod was extended to be connected to the surface buoy by a 180 mm PN 10 pipe. According to the fabric data, this rod resists 15 tons in bend and stretch before break. The 630mm PN 4 cylinder resists 70 tons. Based on input from a professor each buoy would have a maximum traction of 5000 tons. Each pump cylinder has 3 inlet valves represented by 250 mm balls twisted in the POM material. The outlet pipe 250 mm PN 6 from the pump has one 280 mm backspace valve ball twisted in polyethylene. All parts for the 5 pumps were designed, produced and mounted at the Preplast fabric in close cooperation with Ideutvikling.

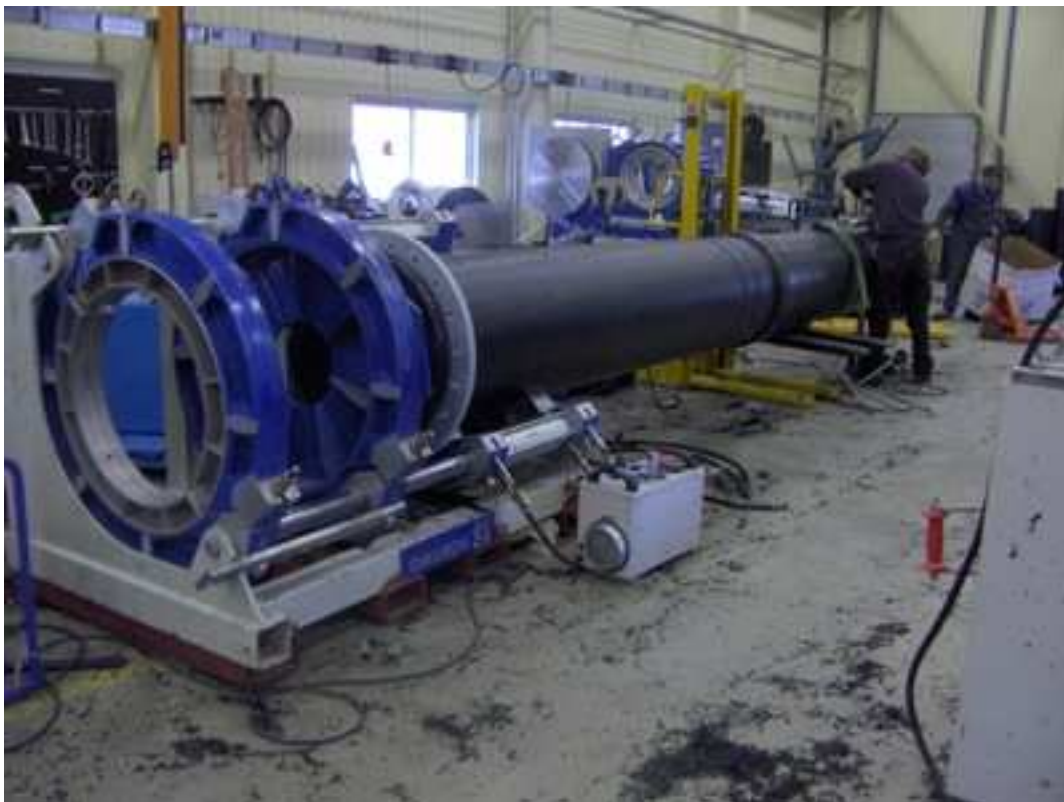

Figure 12 – Prototyping of the pumps



Figure 13 – Torger Tveter (IDEUTVIKLING) working on a pump





Figure 14 – Details of the pumps



Figure 15 – Shipping of the pumps



Figure 16 – Details of the pumps

1.4.3.1 Turbine manufacturing

The turbine has been provided by ABS with the following features:

Construction

The water tight fully flood-proof motor and the hydraulic section form a compact robust unit.

Motor

Single-phase 220-240~, 50 Hz and three-phase 400 V 3 ~, 2-pole (2900 min⁻¹) and 4-pole (1450 min⁻¹), insulation class F, protection type IP 68. Ex protection to international standards e.g. EExdIIBT4 and M/CSA.

Bearings

The rotor shaft is supported in lubricated-for-life ball bearings.

Shaft Sealing

Shaft Sealing between motor and hydraulic section by means of high quality sealing unit using a silicon carbide mechanical seal, independent of direction of rotation and resistant to temperature shock, motor side: Lip seal oil lubricated.

Discharge Outlet

DN 50 (G2") - Internal thread, DN 65 & DN 80 -flange.

Contrablock –system

Contrablock -system consisting of spiral bottom plate with waved shearing inlet and open single channel impeller prevents blockage of the impeller where large proportions of solid or fibrous matter is present. Solids passage 30 mm on 0840 and 45 mm on 0641 CB version.

Vortex Impeller

Hydraulic system with vortex impeller. Solids passage 60 mm for 0630 and 0830 and 40 mm for AS 0530 and 0631 version.

TCS (Thermo Control System)

Thermal sensors in the stator to give a warning and switch off the unit if excessive temperatures are reached in the motor.

Materials

Motor housing: Cast Iron EN-GJL-250
Motor shaft : Stainless Steel 1.4021 (AISI 420)
Volute : Cast Iron EN-GJL-250
Impeller, bottom plate: Cast Iron EN-GJL-250
Fasteners: Stainless Steel 1.4401 (AISI 316)

1.4.3.2 Accessories prototyping

The anchoring platform was constructed on a boat slip. The slip was 25 m long and 5 m wide.

The first step was to weld a bottom frame of steel plates. Then to construct a framework of 25 mm reinforcement bars. Total steel ca. 4000 kg. Around the steel framework was constructed a formwork of wood (400* 500mm) prepared for filling with concrete. The 5 fastening points for the pumps were reinforced and extended. Each point has 20 bolts at 500mm length and 24mm diameter. The bolts were mounted in circle trough a 5mm steel plate which was filled over by 400mm concrete. The complete formwork contained 17 m³ concrete representing a weight of 45 tons onshore. Submerged it represented 30 tons.



Figure 17 – Structure of the anchoring platform



Figure 18 – The anchoring platform

The buoys

In the following table the features of the buoys are shown:

Hull (Weight)	Approx. 50 kg
Shape	Rounded
Dimensions	3m x 1m (W x H)
Buoy Height	1m
Max. Buoyancy	200 kg



Figure 19 – Installation of the buoys



Figure 20– The buoys installed on the test site

1.4.4 Assessment of deployment activities

1.4.4.1 Mounting the pipes on the platform

A mobile crane was used to lift the pumps vertically to enter the flanges to the 24mm bolts. Then it was prepared for mounting the 250mm outlet pipes from each pump. These pipes were welded to a central 315mm pipe. A transportable welding machine was taken to the slip for this job. The 75 kw. ABS converter was then mounted at the end of the central pipe.

The characteristics of the ABS converter, was according to pre calculations well adapted to the power absorption from the 5 buoys/pumps. On the 315 pipe in front of the ABS converter, it was mounted a flow meter (Sitrans MAG 5100) and a pressure sensor (MPA). A level transmitter was also mounted for the purpose of registration of wave amplitudes.



Figure 21 – Construction of the prototype

1.4.4.2 Mounting the buoys

A fish farming boat with a small crane was hired to mount the upper piston rods and the buoys. Two divers were hired to connect and to bolt the upper piston rods. Then the buoys were mounted on the top of the piston rods. This operation went as planned during a long working day.



Figure 22 – Details of the buoys

1.4.4.3 Prototype installation

Two alternatives were considered for sea operation.

One alternative was to mount sufficient buoyancy to the anchoring frame to make it floating and then tow it to the site with one boat. Then sink it at the site by filling water in the balance tanks.



Figure 23 – The prototype hauled by the boats

As we had two boats available, the chosen alternative was to wire connect one boat in each end of the anchoring frame. To take most of the platform load, it was mounted 30 buoys with a total buoyancy of 25 tons. This left ca. 3 tons weight on each boat during the tow.

Before launching, 800m of electric cable was taken onboard. This cable was before launching connected with the ABS converter.

The launching was timed to take place at the high tide when the two boats were connected in each end of the anchoring platform.

Then started a 7 hours tow to the pre destined site. We had no problems during the tow, even in waves up to 1,5 meters, which caused a heavy stress on the platform.

When we arrived at the pre-marked site, the platform was lowered by the boat winches to the bottom at 20 m dept. Then two divers were sent down to release the winch wires and to cut the ropes of the 30 buoys. This gave a spectacular event on the surface when 30 buoys during 15 minutes popped up like projectiles on the surface.

When everything was cleared and the platform safely on the bottom, we started the sinking of the cable in a straight line to the grid connection point onshore. First a cable drum of 400 m was winded out. Then a cable connection was mounted onboard and the next 400 m was winded out. This cable end was left close

to the shore, marked with a small buoy, from where it could be pulled onshore and then connected with the onshore extension to the grid connecting point.

This whole operation was delivered in one long working day.

1.4.4.4 Grid connection

The local energy company was by some unforeseen reason not able to connect the WAVEGEN system to the grid in time before the first storm appeared four days after the final installation. Consequently we lost the opportunity to log some energy production before the piston rod fuse breakdown. The missing generator activation caused an increased stress on the piston rods caused by no turbine flow/pressure resistance to the pipes and pumps.



Figure 24 – Grid connection point

1.4.4.5 Piston rod fuse break

It was stressed very much during the midterm meeting by AREAM that the lower end of the pump cylinders would represent the weakest point in the system. To meet this input, we constructed an even weaker (fuse) point on the upper piston rod than earlier decided. The consequence appeared during the first storm

few days after mounting the buoys when this piston rod fuse broke on each pump. This fuse joint and the piston rods can be reinforced to take many times the load.



Figure 25 – Details of the buoys after the winter storms

1.4.4.6 Status after the winter storms

In March 2008 we sent divers down to check the status of the submerged installation after many heavy winter storms. The photos show that the pump parts have survived 100%. The extension of the basic anchoring frame, where the turbine/generator was mounted, had a damage caused by a big stone. It also appeared that the cable connection with the generator and the registration sensors was damaged.

Based on these facts, we still have a realistic alternative to demonstrate and log production results from the 5 wave pumps. The safest way to obtain these results is to extend the central pipe from the pumps to the nearest onshore location. There we will have an onshore full control in regulation and registration of flow and pressure. This means no vulnerable cables off shore. This work will be prepared during the summer 2008 and the plant will be ready for production during the autumn.

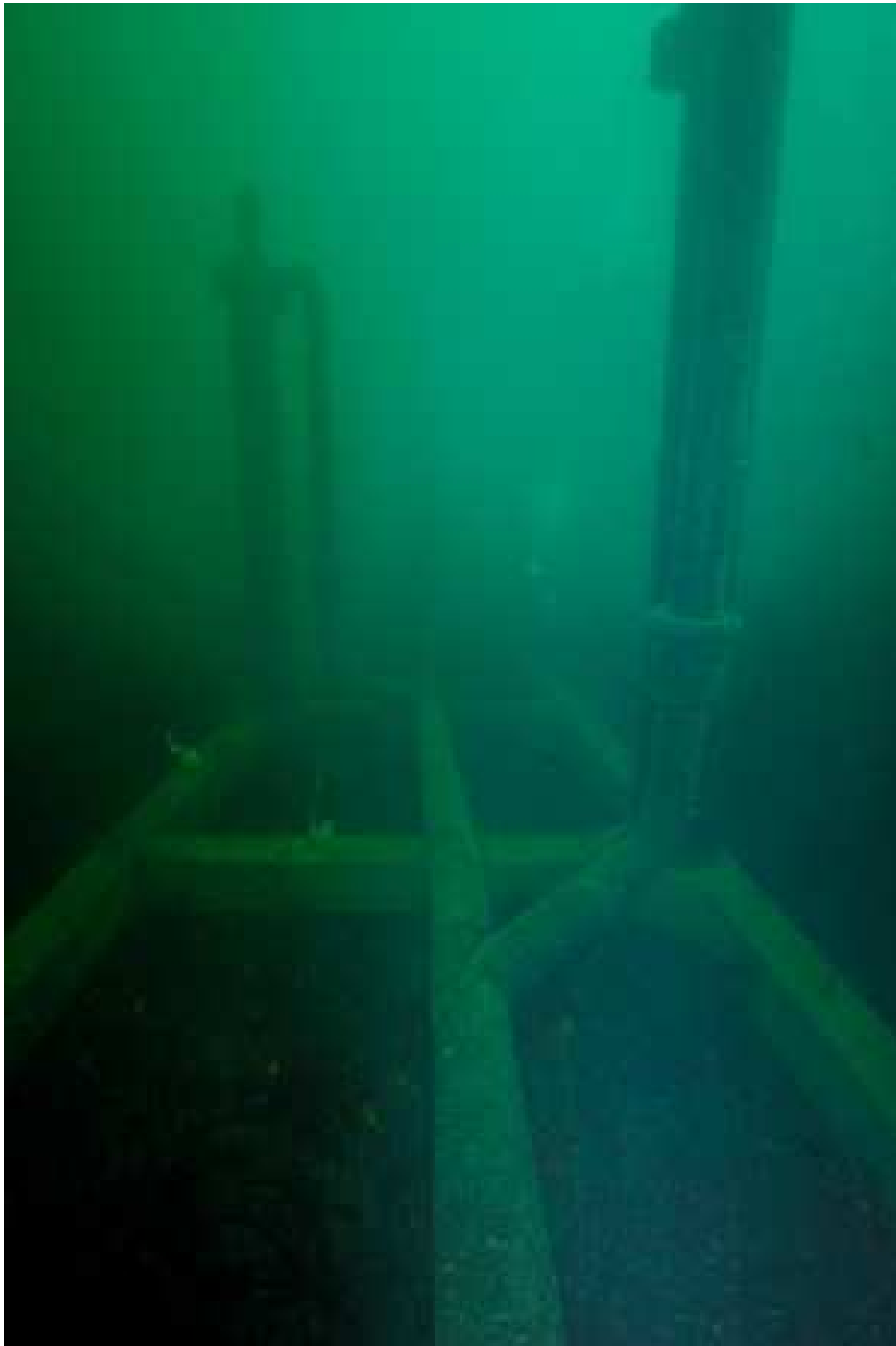

Figure 26 – Underwater images of the prototype



Figure 27 – Detail of the turbine section



Figure 28 – Underwater details of the pumps

1.4.4.7 Technical economical assessment

Technical Conclusions

The project has confirmed that the choice of polyethylene pipes and plates are the most favourable construction material for the pumps and pipes. The construction of the anchoring platform on a simple slip has demonstrated that this complete plant can be built and launched close to any wave energy location at very low cost.

The mounting of 5 pumps to the platform was done efficiently in one day with assistance from a mobile crane. Even a truck crane would be sufficient for this job.

The central pipe connection between the pumps can be completed at the slip by using a transportable welding machine. All equipment was mounted to the platform at the slip before launching.

An alternative to a sub sea turbine/generator is extending the central pipe to an on shore located converter. The advantage of this represents better control and service with the turbine/generator, the cabling and the overall control with the installation. If the distance from the shore location to the wave pumps site, are too long, it will cause some losses in pipe resistance.

The towing and sea operation was managed in full control by smaller boats with winch and crane. It can even be operated by one towing boat.

For deeper waters, an alternative to a bottom based platform is a sub sea buoyancy platform containing of separate bottom anchors fixed with chains in each corner of the platform.

The mounting of the 5 buoys was carried out in one day with no problems.

The constructed joint weak point (fuse) in the piston rod appeared to be too weak and consequently broke in the first storm. The inspection of the broken parts showed that the use of injection moulded collars was a wrong choice. The plastic fabric afterwards admit that this moulded material is weaker than the pipe material, meaning that this parts has to be twisted from extruded bolt or pipe material in which the molecular force is similar to the pipes. A choice of PN 16 and a wider piston rod pipe will also resist many times the load. For future projects this fuse point should also be located just below the buoy part for easier service and repair access.

Anyway, in spite of all the difficulties encountered, the experiences from this prototype have shown that the WAVEGEN concept is now well prepared for a commercial launch. The Consortium looks forward to get the damages repaired during the summer and then to log some production results during the autumn.

SECTION 2 Dissemination and use

2.1 Description of exploitable results

Exploitable Knowledge (description)	Exploitable product(s) or measure(s)	Sector(s) of application	Timetable for commercial use	Patents or other IPR protection	Owner & Other Partner(s) involved
All in one modular integrated system for sub sea power production	Wavegen prototype	Renewable energy sources	Few months after project completion	To be defined if applicable	SMEPs
Modular project and design of sub sea pumps	Fluid dynamic simulations and CAD design	Sustainable energy devices	Few months after project completion	To be defined if applicable	SMEPs

2.1.1 All in one modular integrated system for sub sea power production

2.1.1.1 Description of result

The complete WAVEGEN prototype can be exploited as a product in the market of sustainable energy devices.

The foreseen prototype is a step forward with respect to the other proposed wave energy converters, exploiting the innovative concept of coupling a WAVEPUMP to a submerged turbine.

At this stage of the project, the complete prototype has been successfully installed in the selected testing site, offshore near Molde (Norway).

The prototype is composed of:

- ✓ 100 kW offshore submerged wave energy converter
- ✓ linear array made of 5 WAVEPUMP units made of standard polyethylene pipes, each approximately of the following size:
 - ✓ buoy diameter 3 m
 - ✓ buoy height 1 m
 - ✓ pump cylinder diameter 0.7 m, length 6 m
 - ✓ piston rod diameter 0.2 m, length 15 m
 - ✓ pumps producing flow in a main pipe leading to the sub-sea energy converter, all installed in a common anchoring platform

The system will provide modular and scaleable architecture, allowing easy clustering into arrays, and delivery of flow from a number of pumps into a common sub-sea power generator, or traditional onshore hydropower converter; this prototype is expected to show very interesting features concerning compactness, almost null visual impact, yearly productivity, installation costs, energy production costs.

2.1.1.2 Partners involved

The whole Wavegen prototype has been assembled taking care of three different constitutive aspects:

1. The hydraulic design
2. The mechanic design
3. The electric design

IDEUTVIKLING, with the help of TI and PREPLAST, carried out extensive studies on the basic criteria for piping and valves distribution, pointing out the most suitable configurations and taking into account the necessity of compatibility between hydraulic and anchoring system.

As to the power transfer from subsea to the onshore station, NORPUMP and GEA are cooperating to find out the best possible solution, while as far as power electronics are concerned, LABOR plays a key role.

During the implementation phase, IDEUTVIKLING worked on the final layout of the system, integrating all the different components made available by ABS, NORPUMP and PREPLAST, leading also the challenging installation phase.

On the other side AREAM and EEM, located in Madeira, have carried out extensive studies in order to define the best layout of the system in order to protect it from damages occurring due to the strong horizontal forces acting on the pumps.

2.1.1.3 Possible exploitation

The primary market for wave energy is electricity generation, the connection to which could be at National Grid level, or into the regional or local distribution systems.

It is worth to emphasize that this market opens up a range of secondary products and services, including equipment manufacture, installation, operation and maintenance.

There are also opportunities for using those wave energy converters designed to produce mechanical energy for the desalination of, or mineral extraction from, sea water.

One of the aims of this project is to develop an innovative wave energy conversion technology in order to produce electricity at a competitive commercial cost and with no gaseous emissions (greenhouse or polluting) or waste products.

Successful exploitation of the estimated offshore wave energy resource could make a substantial contribution to the national electricity supply, providing diversity of supply and sustainability in our use of energy; moreover local industrial competitiveness could be strengthened by a domestic wave energy conversion industry.

However wave energy is unlikely, perhaps by 2010, to make a significant contribution to EU targets for energy from renewable sources or greenhouse gas emissions reduction, even if the successful exploitation of wave energy would improve the diversity of EU energy supply and improve energy security, along with the possibility of a significant export potential.

2.1.1.4 Possible market applications

The first and most charming application could obviously be envisaged in the generation of electrical power; to assess what kind of an instrument Wavegen could possibly be, let's take a look at some data.

The total power of waves breaking on the world's coastlines is estimated at 2 to 3 million megawatts. In favourable locations, such the one chosen to install the plant, wave energy density can average 65 megawatts per mile of coastline.

WAVEGEN power device can compare well to offshore wind turbines (the other offshore alternative) in cost-of-electricity (3-5cents/kWh6 vs. 6-9 cents/kWh7) and non-tangible benefits.

As to the economic consideration, effective cost estimates of energy produced by WAVEGEN prototype are dependent on many physical factors, such as system design, wave energy power, water depth, distance from shore, and ocean floor characteristics.

Economic factors, such as assumptions on discount rate, cost reductions from a maturing technology, and tax incentives, are also critical.

For example a detailed evaluation of potential wave energy development in the U.S. coastal areas has been conducted, taking into account variability in these factors (Bedard et al. 2005).

The resulting cost estimate of electricity from the first commercial-scale facilities in the California, Hawaii, Oregon, and Massachusetts offshore regions with relatively high wave energy was in the range of \$0.09 to \$0.11/kWh, after tax incentives.

These facilities are very capital intensive, and these costs currently have a high degree of uncertainty. For example, capital investment cost estimates for the applications noted above range from \$4,000 to \$15,000/kW, suggesting that significant breakthroughs in capital cost would be needed to make this technology cost competitive.

This is the intention of WAVEGEN, that aims to decrease the production cost down to 0.047 – 0.065 €/kW.

As for the targeted market, The assessment of the commercial prospects for wave energy has been a hotly debated field. There are a number of historic reasons for this but, perhaps, there is one underlying cause: until the technology matures, estimates of the cost of power from wave energy devices “represent a snapshot of the status and costs of the designs at (the current) stages of their development” (Thorpe, 1992).

That review found support for this proposition, with the predicted generating costs of several devices being reduced by factors of two or more as part of the review activities.

The electricity costs of a number of devices have been evaluated more recently using the same peer-reviewed methodology developed for the last UK review of wave energy (Thorpe, 1999). The resulting costs have been plotted in Figures 1 and 2 against the year in which the design of the demonstration device was completed. These figures show that there have been significant improvements in the predicted generating costs of devices, so that there are now

several with costs of about 5 p/kWh (= US 8 ¢/kWh) or less at 8% discount rate (if the devices achieve their anticipated performance). This indicates that, if these devices can be successfully built and operated, wave energy is already economically competitive in niche markets such as supplying electricity to isolated communities that are not connected to the grid. Furthermore, wave energy has good prospects of being commercially competitive with conventional large scale power generation (e.g. coal) following further R&D.

It should be emphasised that the predicted costs of generation for the most recent devices are for sites chosen by the device designers. Hence, having different wave power levels and transmission distances, the predicted costs of the devices cannot be compared directly with each other. Instead, these costs should be taken as indicative only.

In addition:

These costs assume serial production and, as such, they are not expected to be achieved for several years;

There is uncertainty attached to these costs, which can be overcome only by gaining actual construction and in-service experience.

Several of the design teams claim lower costs than those presented, for instance the Hosepump is claimed to have generating costs of 2.4 - 4 p/kWh (Eurowave, 1997).

There are well advanced plans to increase the wave energy capacity in the world to nearly 6 MW in the next few years. Further predictions for future world-wide capacity are, at present, speculative but several companies have plans for the deployment of several MWs per year in the period 2005-2010, with increasing deployment thereafter.

An assessment of the likely markets has been made, taking into account competing sources of electricity (Thorpe, 1999). This indicated that, if the wave energy devices performed as predicted, then their economic contribution would be > 2000 TWh/year. This would correspond to an investment of over £ 500 billion.

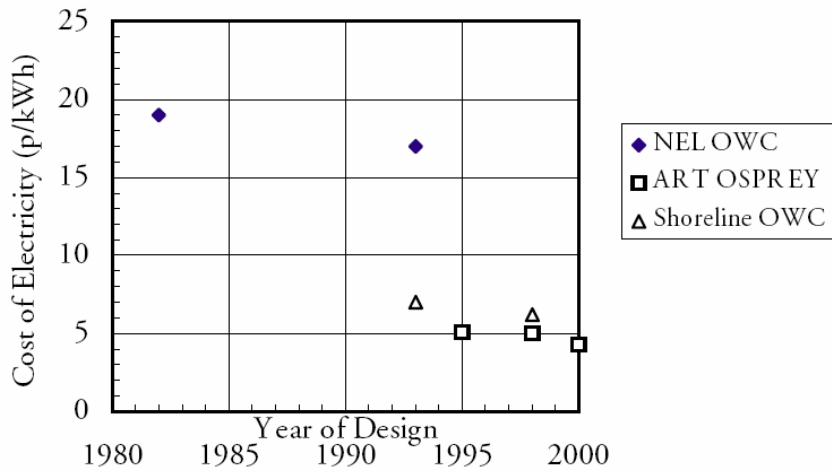

Key. * at 8% discount rate.
 Costs for year 2000 design incorporate improvements already quantified.

Figure 29 – Evolution of Predicted costs for OWC*

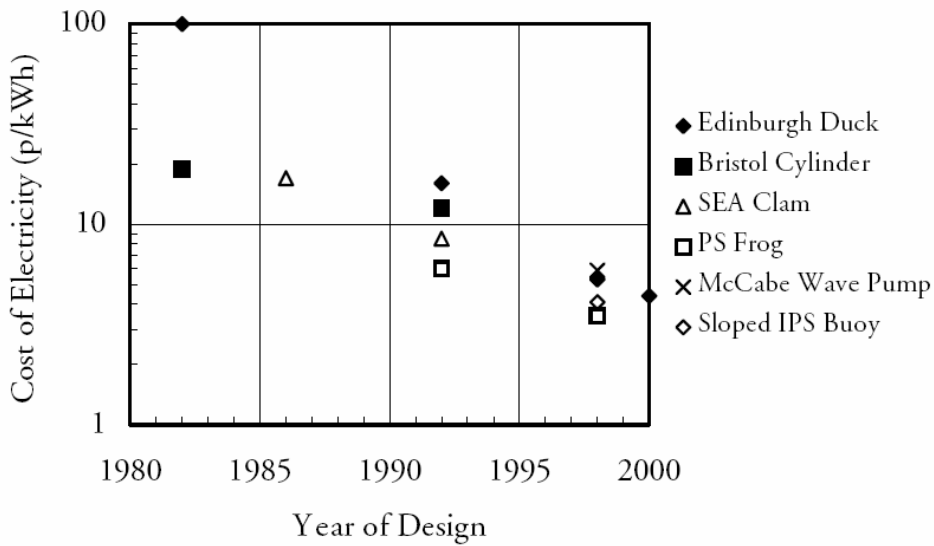

Key. * at 8% discount rate.
 Costs for year 2000 design incorporate improvements already quantified.

Figure 30 – Evolution of Predicted electricity costs for off shore plants*

Energy Type	Energy Density	Predictability	Availability	Potential Sites
Wave Energy	Low to Moderate	Predictable in most sites	80-90%	Extensive but can become Limited
Combustible Fuels	Very High	Predictable	80-90%	Extensive
Wind	Low	Unpredictable except in limited number of sites	30-45%	Limited
Solar	Low	Unpredictable except in limited number of sites	20-30%	Limited

Figure 31 – Availability of natural energy sources

Another possible usage of WAVEGEN could be in the desalinization process by providing desalinated water through reverse osmosis at economic rates. This would open up a new large and important market for wave energy.

In fact the growing scarcity of freshwater is driving the implementation of desalination on an increasingly large scale. However, the energy required to run desalination plants remains a drawback.

The idea of using renewable energy sources is fundamentally attractive and many studies have been done in this area, mostly relating to solar or wind energy and Wavegen device, with some arrangements, could be effectively adopted in this sector.

ENVIRONMENTAL IMPACT, COMPARISON OF ENERGY SOURCES ⁸							
KEY: NEG = negative effect POS = positive effect	ENERGY SOURCE						
	Fuel	Wind	Solar	Wave, onshore	Wave, offshore terminator	Wave, offshore point absorber	WOPAC
Air pollution	NEG						
Noise pollution	NEG	NEG					
Visual obtrusiveness	NEG	NEG	NEG	NEG			
Real estate consumption	NEG	NEG	NEG	NEG			
Beach dynamics					POS	POS	POS
Marine life					POS	POS	POS
Navigation					NEG	NEG	SLIGHT NEG

WAVE ENERGY COMPARISON TO OTHER RENEWABLES

	OPT Wave Power	Solar	Wind
Energy Density and Predictability	High	Low	Low
Availability	90%	20%-30%	20%-30%
Potential Sites	Virtually Unlimited	Limited	Very Limited
Average Power Output Per Plant	Scaleable to 100+MW	Scaleable to 5 MW	Scaleable to 30 MW
Environmental Issues	None	Visual Pollution	Noise and Visual Pollution
Fuel	None	None	None
Power Station Cost/kW			
Secondary	\$6,200 (a)	\$10,000 (b)	\$3,000 (b)
Primary	\$2,300 (a)	\$4,500 (b)	\$1,000 (b)(c)
Energy Cost/kWh			
Secondary (d)	7-10¢	25-50¢	10¢ (c)
Primary (e)	3-4	10-15	5-6 (c)

However, green electricity producers face a number of barriers.

First, the decision on conditions for connection to the grid is valid for two years and reserves a necessary capacity during this time no other investor can utilise the reserved capacity.

This is abused by many investors who - without real plans of installing RES plant- want to reserve the possibility to connect to the grid until it's not necessary to extend it and to cover significant costs of this extension. When the whole capacity of electricity transmission is "utilised", all other investors have to wait or pay costs of the extension. Secondly, the agreement on sale/purchase of electricity is valid only for few years (most of the time one year), which doesn't provide any credibility for investor in the point of view of the bank; indeed it is difficult to obtain a loan for investment.

There is also a lack of tariffs for transmission of electricity from medium voltage through high and again to medium voltage, thus the utility can refuse to carry out the connection because they do not have tariffs legally approved by local and national authorities.

2.1.2 Modular project and design of subsea pumps

2.1.2.1 Description of result

In the field of turbo-machinery, CFD is becoming an important tool to compute the flow field inside turbines and compressors [Lakshminarayana, 1996].

Computational fluid dynamics (CFD) analysis of these systems provides valuable insight to what is physically happening to the tools at these high pump rates and proppant loads.

Analyzing various variables, such as velocity, fluid path, waves amplitude, helps identify critical areas within the system that require design optimization.

CFD analysis is a cost effective alternative to trial-and-error testing, which can cost a lot of money per test and prolong the development phase. Computational fluid dynamics software or CFD software is an important part of building and analyzing a flow model.

The first step performed by Prof. Krogstad was the construction of the flow model.

Then the model has been implemented in a FORTRAN software, as described in D3. This methodology computes movement through fluidic systems using numerical methods called finite difference, in order to describe the phenomena occurring in Wavegen system. During the second year of the project, the computational fluid dynamic simulations allowed to validate the layout chosen for Wavegen, also providing some recommendations and guidelines for reducing the risks of mechanical breakdown and for optimising the energy production.

This approach is very flexible, allowing to analyse different configuration of off-shore wave energy plant.

2.1.2.2 Partners involved

Prof. Krogstad, for TI, performed the design of the model and the software simulation by implementing the code both in FORTRAN and in MATLAB programming languages. Many aspects have been discussed and faced in cooperation with LABOR, along with simulations have been performed.

2.1.2.3 Possible exploitation

CFD analysis is a fundamental tool in the design of system such as submersible power generators and the work performed could be exploited in the assessment of the feasibility and the most critical parameters to take into account while drawing up a renewable energy plant.

The program Wavesim, developed in this project, is parametric and modular enough to give engineers, who wants to face a challenge akin to that presented by Wavegen, the opportunity to simulate the environment in which the plant will be installed.

2.1.2.4 Possible market applications

Although it is not actually a product but a methodology, CFD and in particular Wavesim, with some improvements, could represent a good mean to speed up the design phase of submersible plants and reduce the cost of tests.