

Figure 1 – Brake Slave Unit

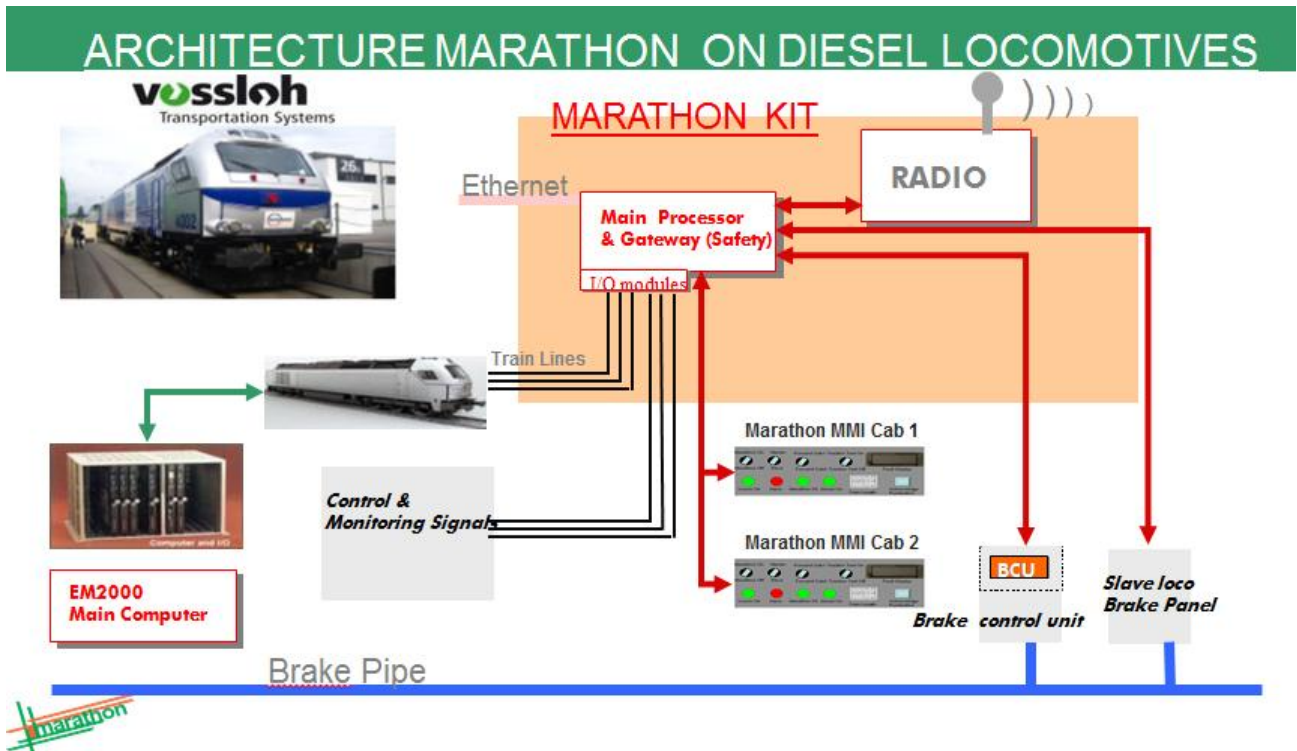

Figure 2 – MARATHON Architecture on Diesel Locomotives

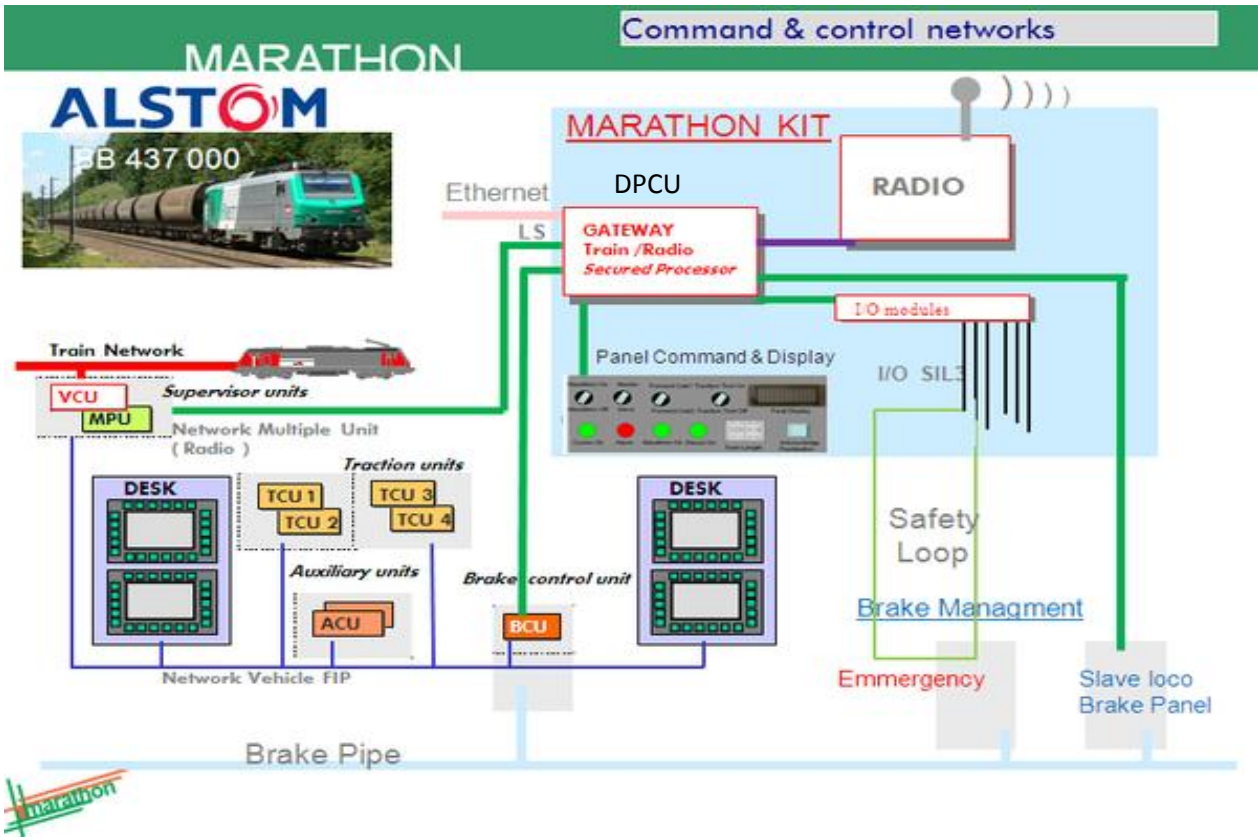

Figure 3 – MARATHON Architecture on BB 437000 Locomotives



Figure 4 – Installation of MARATHON Kit on a BB 437000 Locomotive



Figure 5 – Installation of MARATHON Kit on EURO 4000 Locomotive

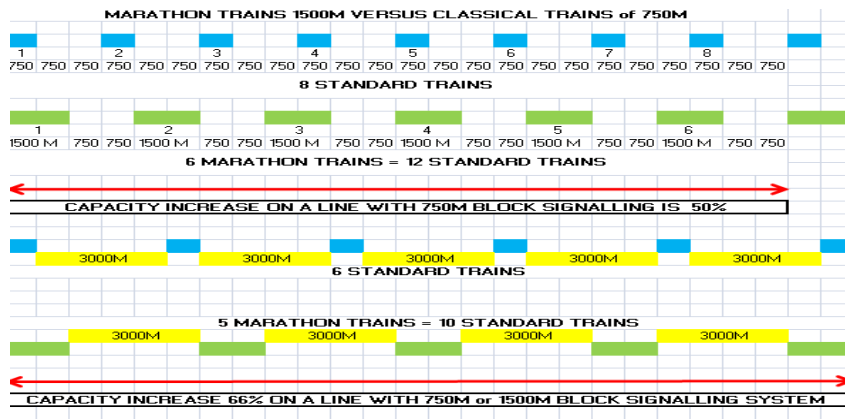

Figure 6 – MARATHON – Capacity Results



Figure 7 –MARATHON Achievements