



ALLEGRA Project
**ADVANCED LOW NOISE LANDING (MAINSKY
AND NOSE) GEAR FOR REGIONAL
AIRCRAFT**

GRANT AGREEMENT NO: 308225

JTI Clean Sky GRA ITD

ALLEGRA Consortium

www.cleansky.eu



Project Overview

❖ **Call SP1-JTI-CS-2011-03 – 29th July 2011**

❖ **Project Partners:**

Organisation name		Country
1. [CO] Trinity College Dublin	TCD	Ireland
2. Royal Institute of Technology	KTH	Sweden
3. Magnaghi	MAGNAGHI	Italy
4. PininFarina	PININFARINA	Italy
5. tecknosud	tecknosud	Italy
6. Eurotech	EUROTECH	Italy



❖ **Project Start Date – 1st January 2013**

❖ **Duration**

▶ 24 months + 5 month extension = 29 months



Project Overview

- ❖ The ALLEGRA project has been developed in response to the requirements of the European Clean Sky Joint Technology Initiative to assess low noise technologies applied to both nose and main landing gear architectures
- ❖ In the past full-scale models of landing gear have rarely been tested due to the large test facilities required
- ❖ Most experimental airframe noise research has been performed using small-scale models
- ❖ One of the significant contributions of ALLEGRA is that a full representation of the landing gear detail and associated structures (e.g. bay cavity, bay doors, belly fuselage etc.) will be included and addressed at a realistic scale
- ❖ The nose landing gear is designed at full scale and the main landing gear at half scale



Project Overview

WP1 - Main Landing Gear Studies

- ❖ **T1.1: Identification, preliminary evaluation and first down-selection of MLG low-noise solutions**
- ❖ **T1.2: Specific design of MLG low noise solutions**
 - ▶ ST1.2.1: Preliminary design of MLG
 - ▶ ST1.2.2: Preliminary structural analysis of MLG
- ❖ **T1.3: Theoretical assessment and down-selection of MLG low-noise solutions for WTT**
- ❖ **T1.4: Aero-acoustic WTT of MLG baseline and low-noise configurations**
 - ▶ ST1.4.1: Definition of test program
 - ▶ ST1.4.2: Executive design of MLG
 - ▶ ST1.4.3: Manufacturing and modal testing of MLG
 - ▶ ST1.4.4: Experimental setup and tunnel characterization
 - ▶ ST1.4.5: Wind tunnel test
- ❖ **T1.5: WTT results analysis and final assessment**
 - ▶ ST1.5.1: Acoustic characterization of WT for far field and near field noise
 - ▶ ST1.5.2: Acoustic test analysis of MLG measurement



Project Overview

WP2 - Nose Landing Gear Studies

- ❖ **T2.1: Identification, preliminary evaluation and first down-selection of NLG low-noise solutions**
- ❖ **T2.2: Specific design of NLG low noise solutions**
 - ▶ ST2.2.1: Preliminary design of NLG
 - ▶ ST2.2.2: Preliminary structural analysis of NLG
- ❖ **T2.3: Theoretical assessment and down-selection of NLG low-noise solutions for WTT**
- ❖ **T2.4: Aero-acoustic WTT of NLG baseline and low-noise configurations**
 - ▶ ST2.4.1: Definition of test program
 - ▶ ST2.4.2: Executive design of NLG
 - ▶ ST2.4.3: Manufacturing and modal testing of NLG
 - ▶ ST2.4.4: Experimental setup and tunnel characterization
 - ▶ ST2.4.5: Wind tunnel test
- ❖ **T2.5: WTT results analysis and final assessment**
 - ▶ ST2.5.1: Acoustic characterization of WT for far field and near field noise
 - ▶ ST2.5.2: Acoustic test analysis of NLG measurement



Project Overview

WP3 Management and JTI GRA Interaction

- ❖ T3.1: Scientific coordination
- ❖ T3.2: Financial and administrative coordination
- ❖ T3.3: Intellectual property and confidential issues management within JTI-GRA

Input to GRA Low Noise Down Selection (TCD & Magnaghi)

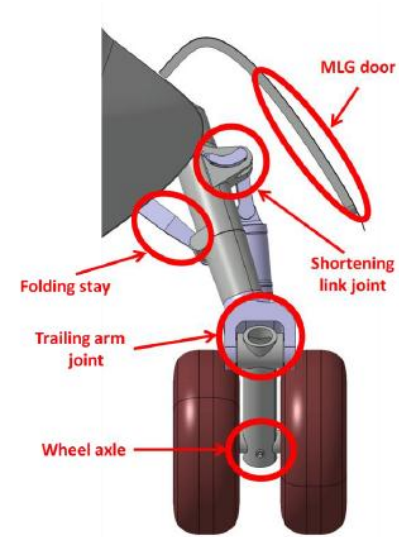

MLG

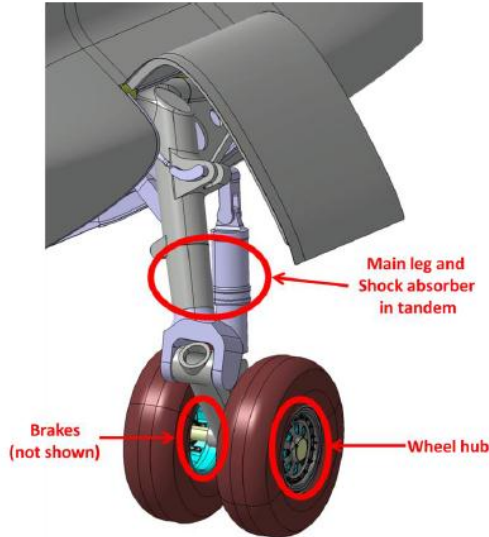

The best solutions proposed are:

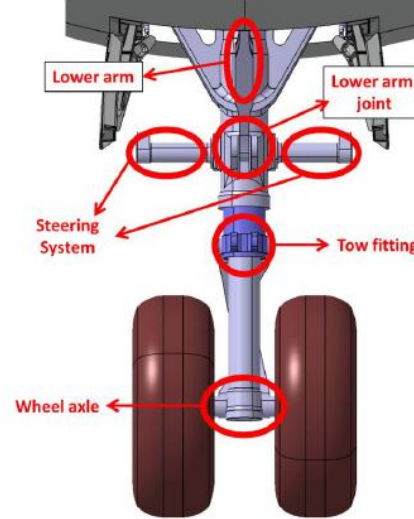

NLG

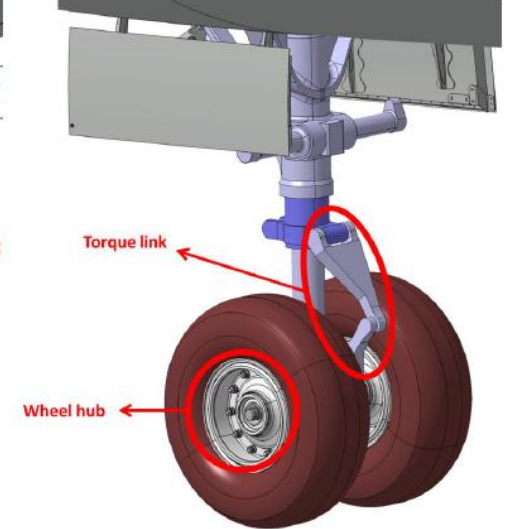

Rank	ID	Description	Total
1	1	Fairings	24
2	8	Meshes	24
3	6	Wheel hub caps	22
4	7	Hole covering	22
5	2	Deployable ramp type fairing (bay protection)	20
6	9	Air curtain	19
7	3	Optimised bay door design	18
8	4	Optimised component design	18
9	10	Plasma actuators	18
10	5	Acoustic treatment of landing gear bay (cavity)	17
11	11	Vortex disintegrators	17
12	12	Boundary layer suction	15



Wind Tunnel Model Design and Manufacture (Tecknosud, Eurotech, Magnaghi)

- The purpose of the activity was the development and manufacturing of scale wind tunnel models for testing of noise reduction solutions in landing gears area.
- They have been developed two different models (full scale for NLG and half scale for MLG) reproducing simplified external lines of Advanced Turboprop lower fuselage, main and nose landing gears and landing gear bay and doors, starting from reference surfaces up to the physical mock-up.
- Furthermore low noise devices have been developed, modeled, realized and integrated into the Baseline Model, in accordance with Alenia Aermacchi and GRA down-selection

Wind Tunnel Model Design and Manufacture (Tecknosud, Eurotech, Magnaghi)

INPUT SURFACES

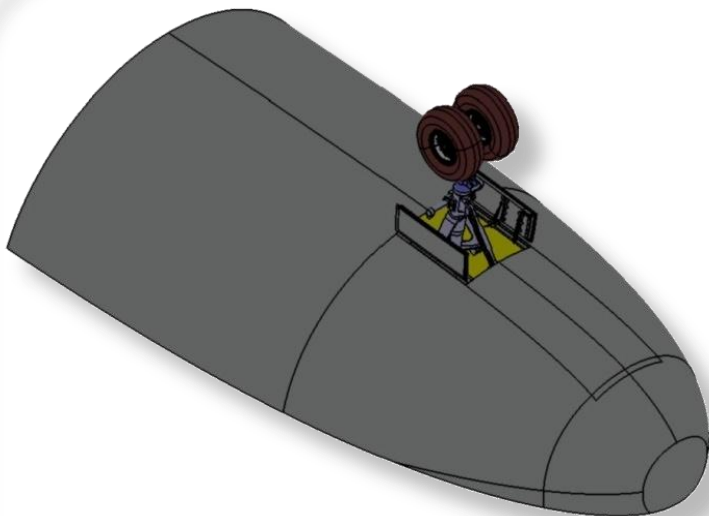

NLG Reference Surfaces

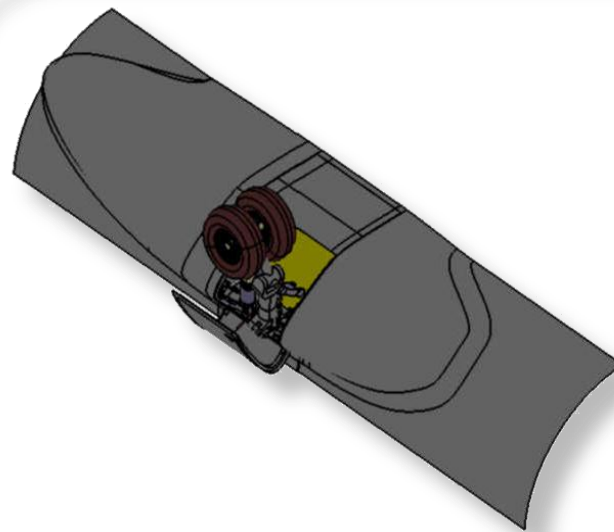

MLG Reference Surfaces

Wind Tunnel Model Design and Manufacture (Tecknosud, Eurotech, Magnaghi)

FROM INPUT TO FINAL SHAPE

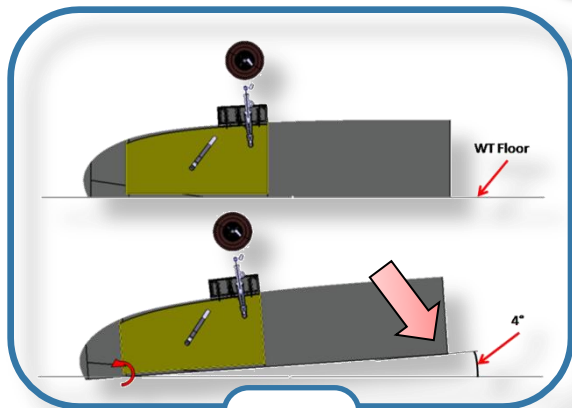

NLG

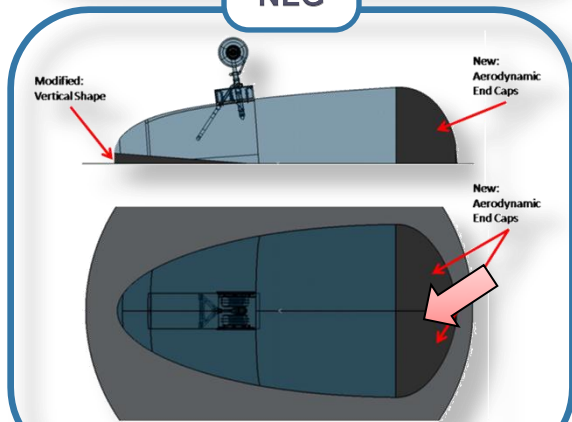

NLG Final Shape Definition

The first step was to reconstruct the external surfaces of the models.

Because of test specifications, reference surfaces has been rotated to match 4° attach angle and interface surfaces has been modified or redesigned were missing.

New aerodynamic caps was developed in order to avoid any issues with air flow in wind tunnel.

Surfaces are reconstructed in order to close gaps with WT floor.

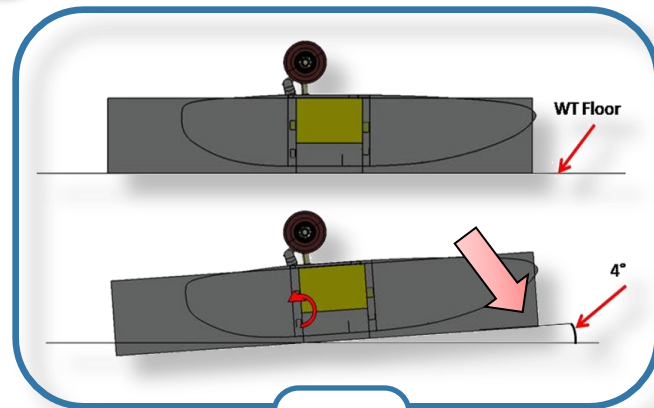

MLG

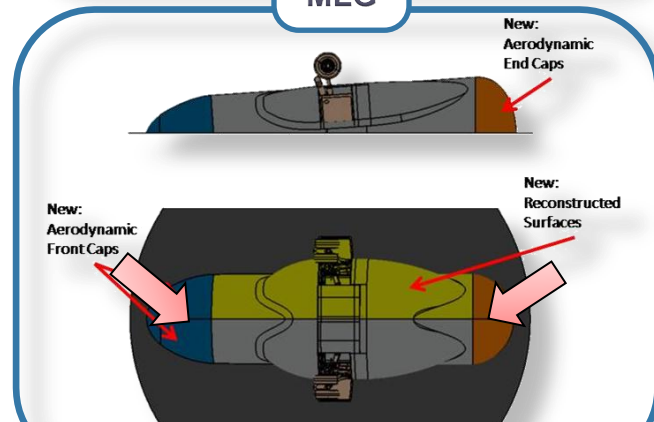

MLG Final Shape Definition

Wind Tunnel Model Design and Manufacture (Tecknosud, Eurotech, Magnaghi)

FROM SHAPE TO CAD MODEL

Input Surfaces

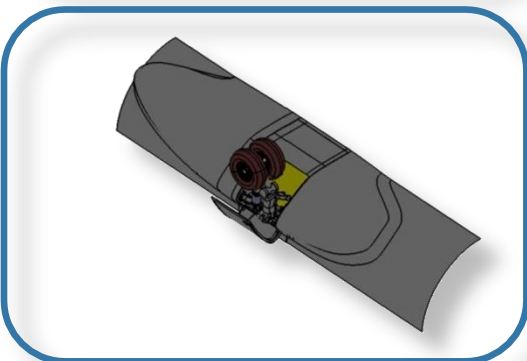
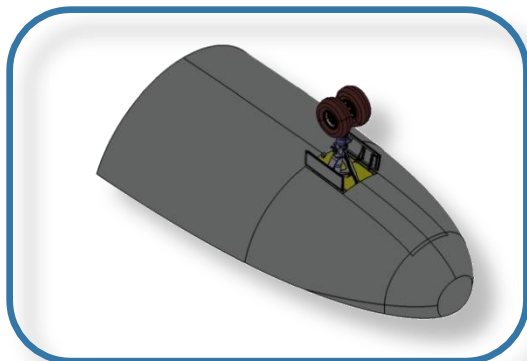

Definitive Shape



NLG



MLG



Definitive CAD Model

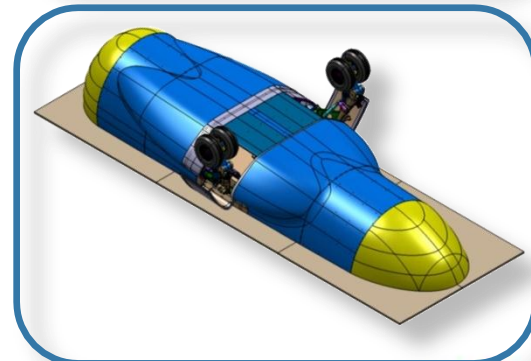
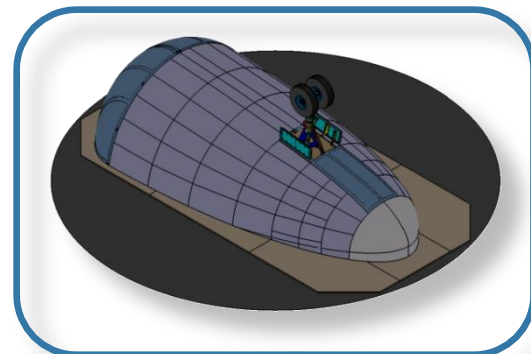

Wind Tunnel Model Design and Manufacture (Tecknosud, Eurotech, Magnaghi)

NLG BASELINE DIMENSIONAL CHARACTERISTICS

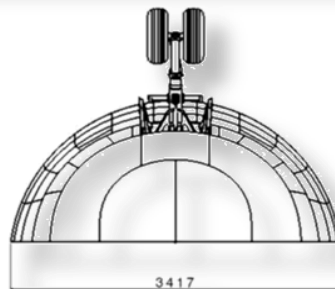
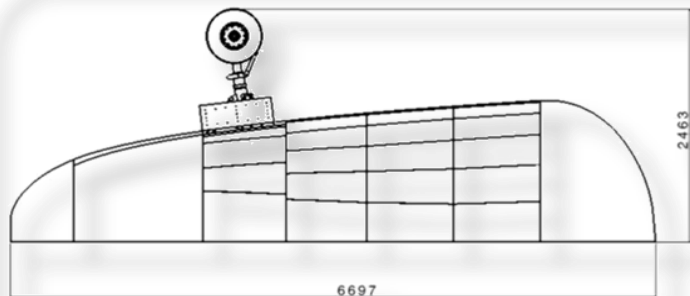

Geometrical Dimensions

WIND TUNNEL
FAN AREA

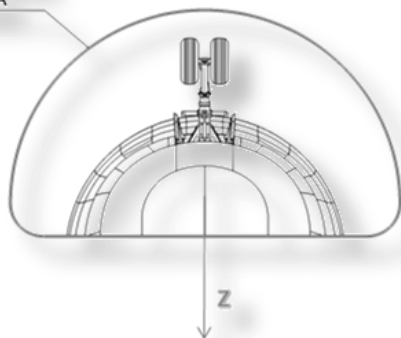

WIND TUNNEL
ROTATING FLOOR

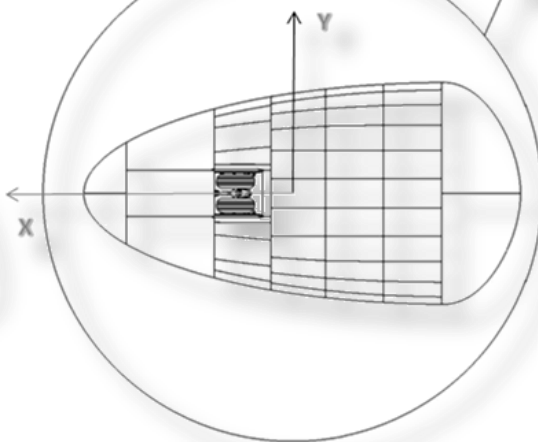

Wind Tunnel
Occupation Area

Wind Tunnel Model Design and Manufacture (Tecknosud, Eurotech, Magnaghi)

MLG BASELINE DIMENSIONAL CHARACTERISTICS

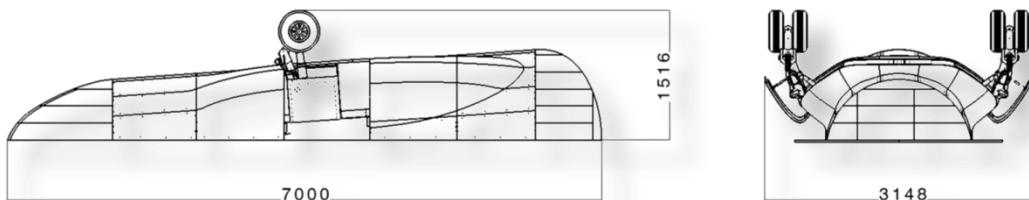

Geometrical Dimensions

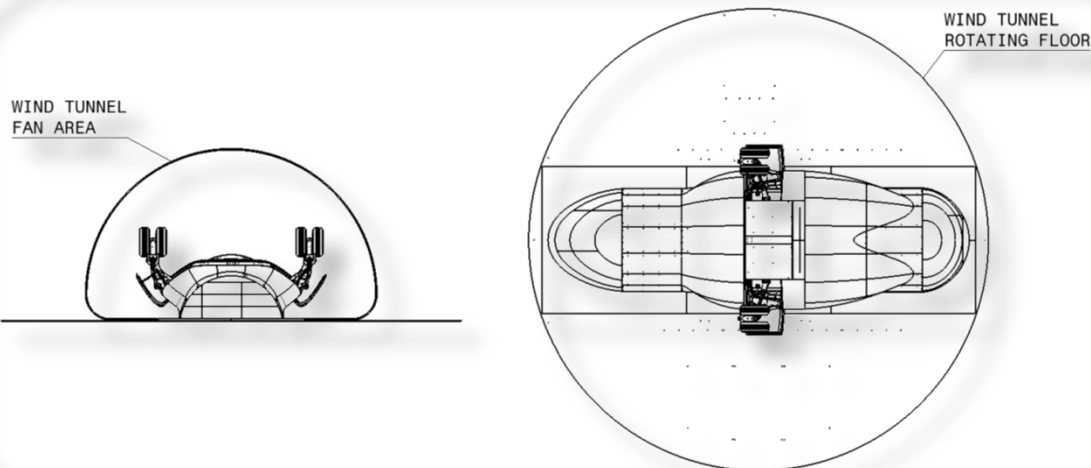

Wind Tunnel Occupation Area

Wind Tunnel Model Design and Manufacture (Tecknosud, Eurotech, Magnaghi)

MATERIAL TABLE

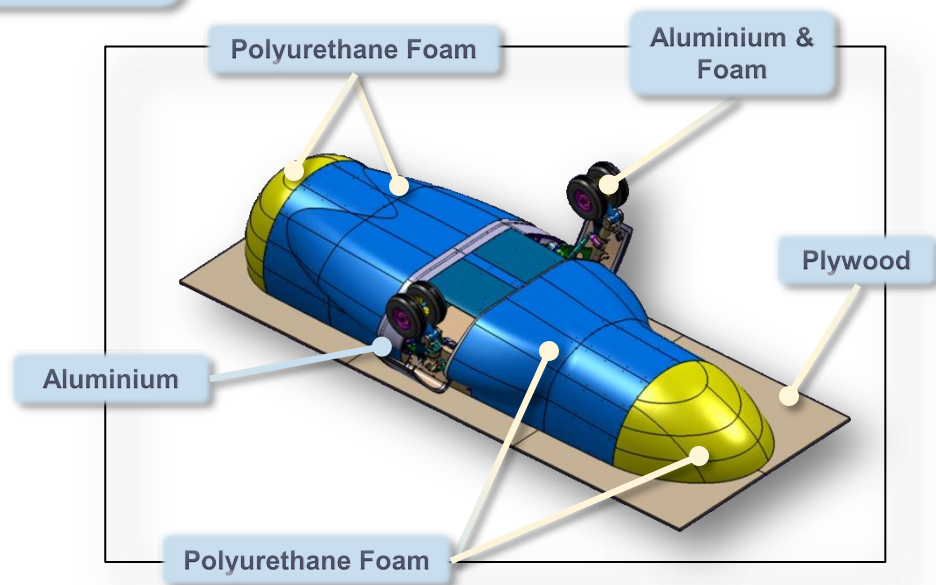
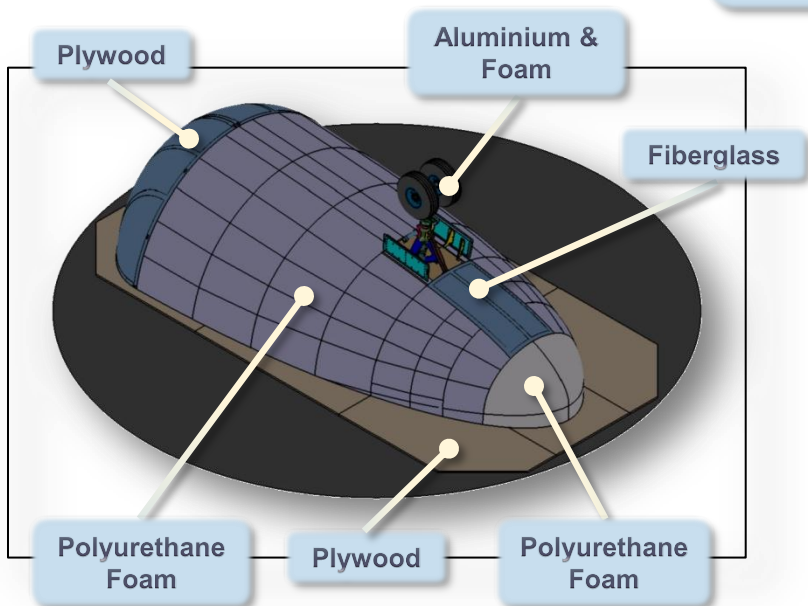

ITEM	MATERIAL
EXTERNAL SKIN	POLYURETHANE FOAM
END CAP	PLYWOOD
FRONT CAP	POLYURETHANE FOAM
MAIN STRUCTURE	STEEL
BAY STRUCTURE	PLYWOOD & STEEL
LG MOCK-UP	ALUMINIUM & FOAM

ITEM	MATERIAL
EXTERNAL SKIN	POLYURETHANE FOAM
FRONT & END CAPS	POLYURETHANE FOAM
MAIN STRUCTURE	ALUMINIUM
BAY STRUCTURE	PLYWOOD & ALUMINIUM
BAY COVER	ALUMINIUM
LG MOCK-UP	ALUMINIUM & FOAM
FLOOR	PLYWOOD

Wind Tunnel Model Design and Manufacture (Tecknosud, Eurotech, Magnaghi)

NLG LOW NOISE SOLUTIONS

C
O
N
C
E
P
T

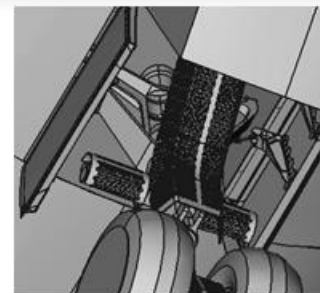
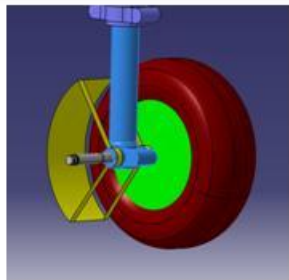
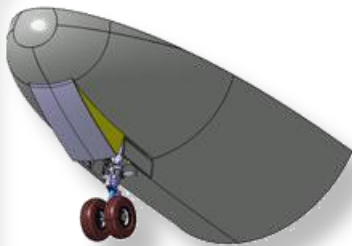

C
A
D
M
O
D
E
L
S

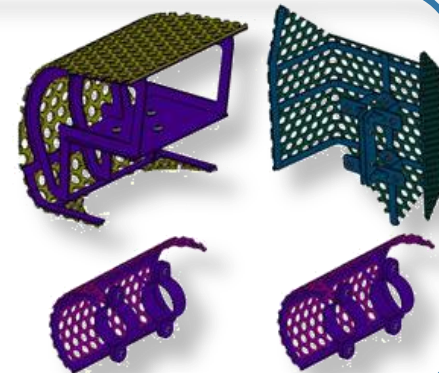
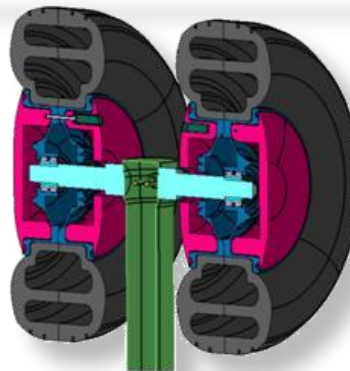
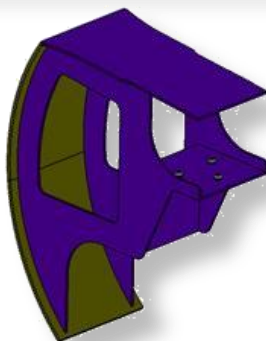
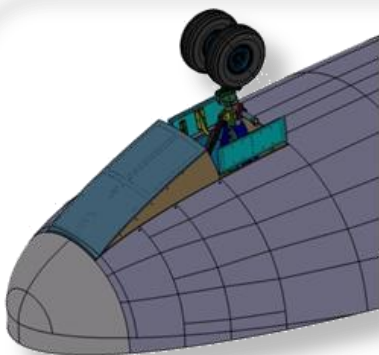

Wind Tunnel Model Design and Manufacture (Tecknosud, Eurotech, Magnaghi)

NLG LOW NOISE SOLUTIONS

CAD MODELS

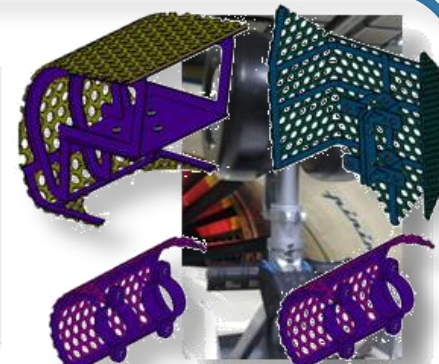
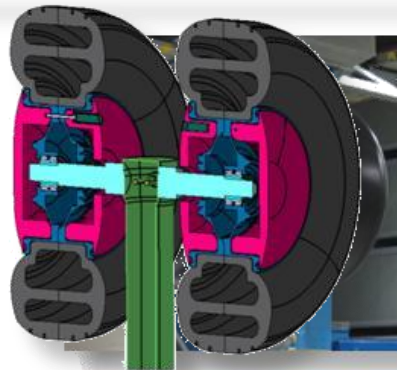
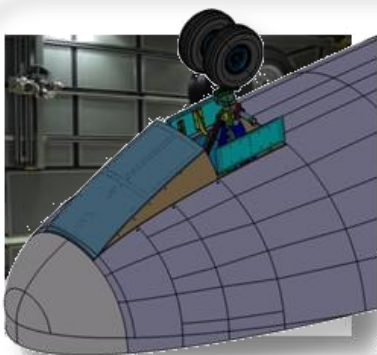

Wind Tunnel Model Design and Manufacture (Tecknosud, Eurotech, Magnaghi)

NLG LOW NOISE SOLUTIONS

CAD MODELS

CAD MODELS

DEVICES

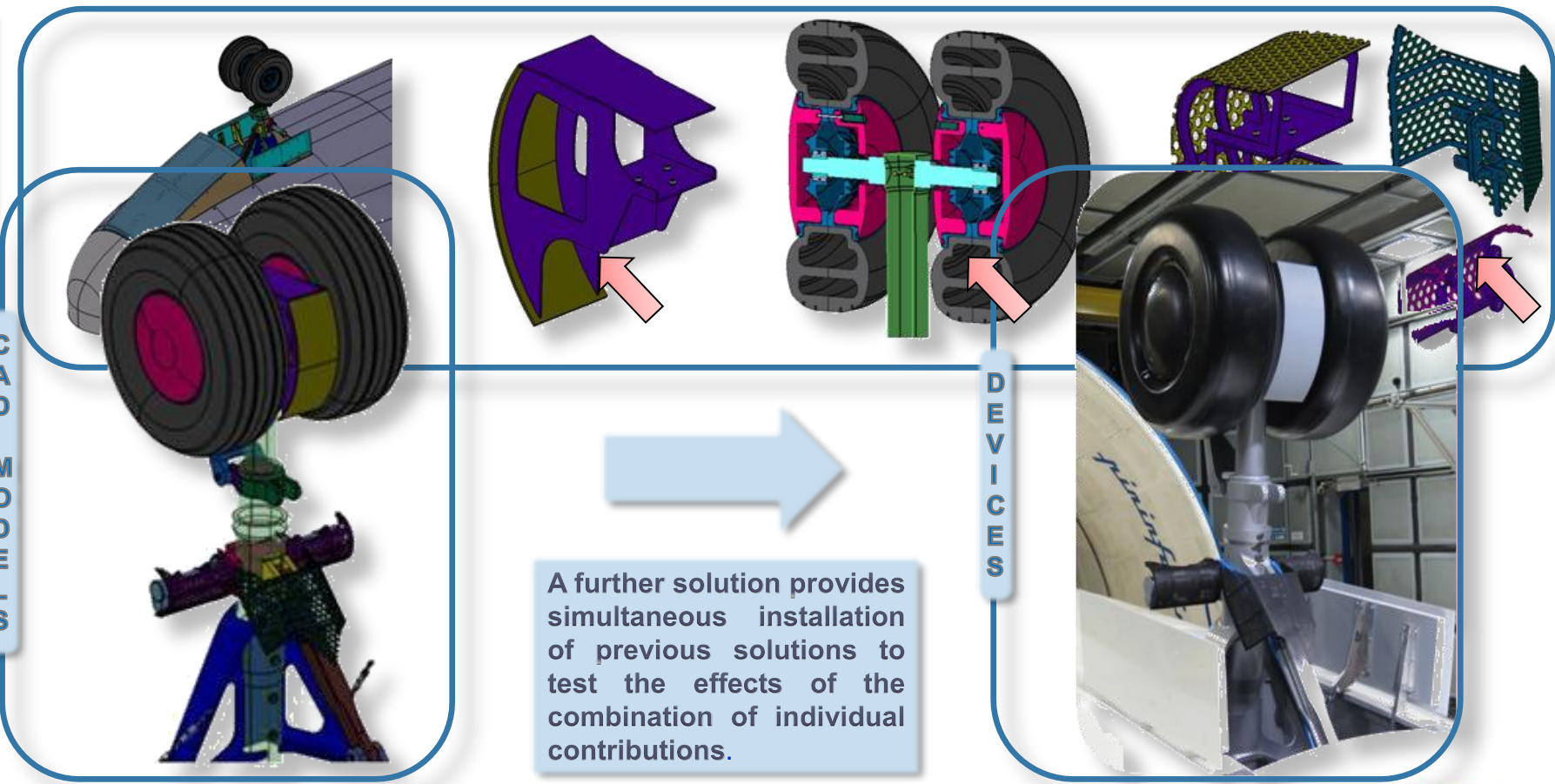

Wind Tunnel Model Design and Manufacture (Tecknosud, Eurotech, Magnaghi)

MLG LOW NOISE SOLUTIONS

C
O
N
C
E
P
T

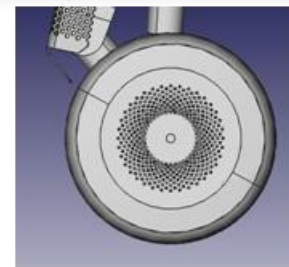
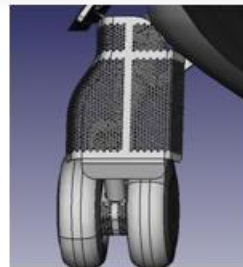

C
A
D
M
O
D
E
L
S

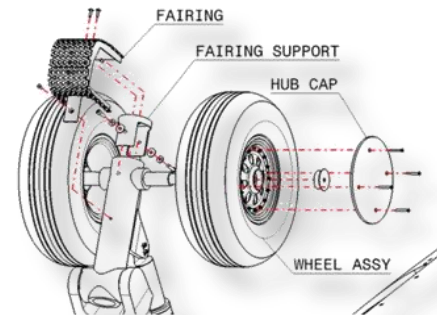
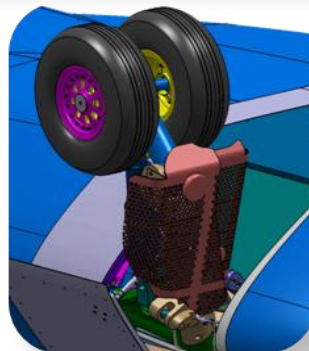
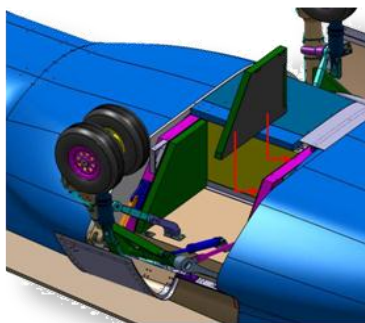
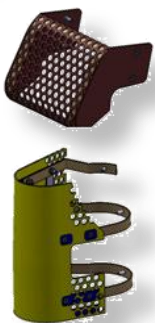

Wind Tunnel Model Design and Manufacture (Tecknosud, Eurotech, Magnaghi)

MLG LOW NOISE SOLUTIONS

C
D
E
V
I
C
E
S

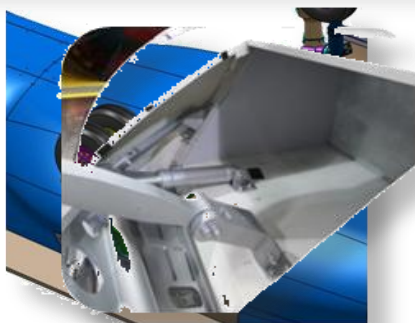

Wind Tunnel Model Design and Manufacture (Tecknosud, Eurotech, Magnaghi)

MLG LOW NOISE SOLUTIONS

A further solution is MLG Baseline with Fully-Open Bay

C
A
D
M
O
D
E
L
S

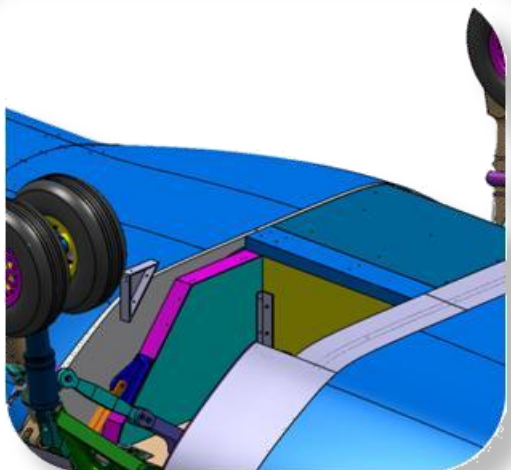

D
E
V
I
C
E
S



Wind Tunnel Model Design and Manufacture (Tecknosud, Eurotech, Magnaghi)

NLG WT CAD MODEL



PRE - RENDERING



NLG WT PHISICAL MODEL



Wind Tunnel Model Design and Manufacture (Tecknosud, Eurotech, Magnaghi)

MLG WT CAD MODEL

PRE - RENDERING

MLG WT PHISICAL MODEL

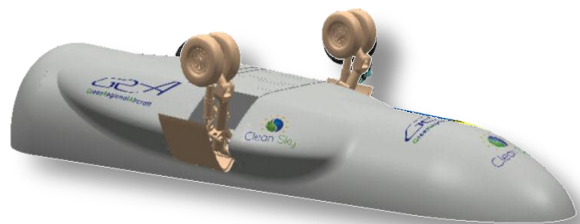

CFD and CAA Simulation (KTH)

- The work process starts with CAD files of the main landing gear geometry provided by Tecknosud.
- These are detailed CAD files that correspond to the manufacturing model tested in the wind tunnel.
- The CAD must be remodelled and simplified to obtain an adequate water-tight surface for meshing.
- The preliminary RANS solution is fed as initial condition to the full unsteady flow simulation (DES) and the pressure fluctuations on the landing gear surface are recorded.
- Finally, these surface pressure time series are used to run a FWH solver which computes the sound propagation to far-field microphones.

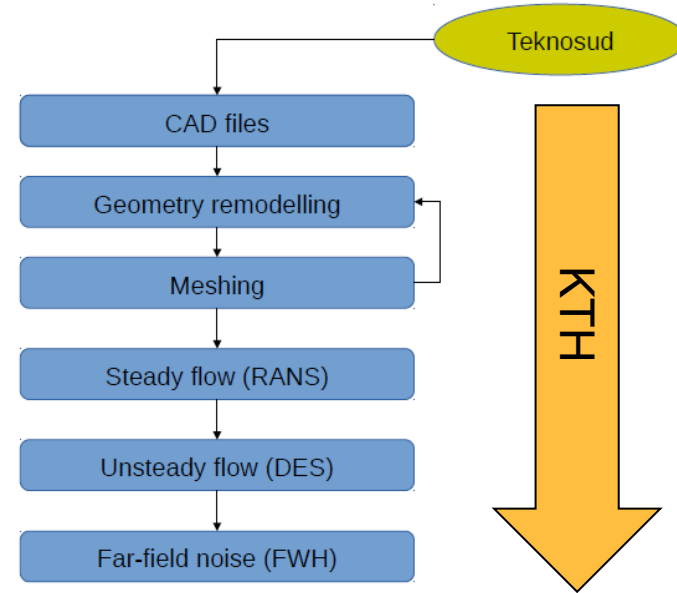

CFD and CAA Simulation (KTH)

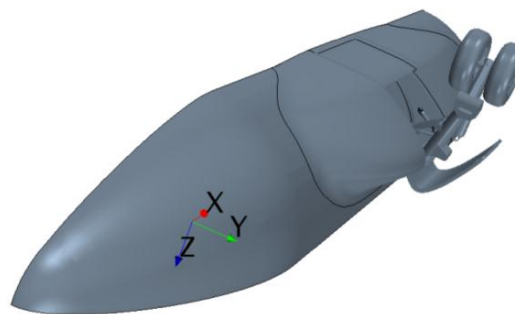
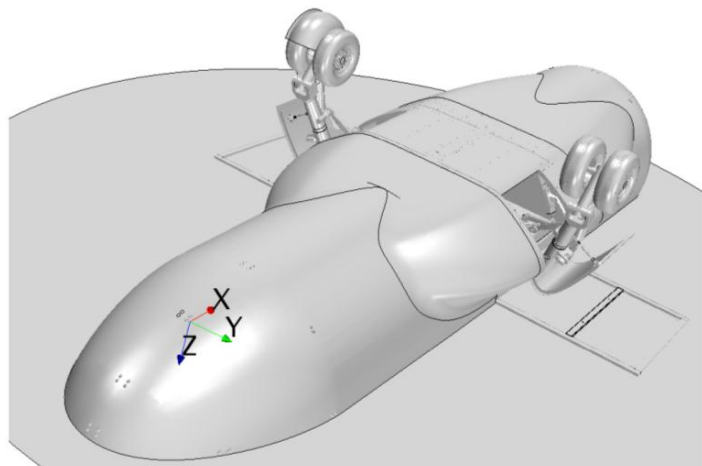

Comparison of
Tecknosud CAD files
(left) and KTH CFD input
(right)

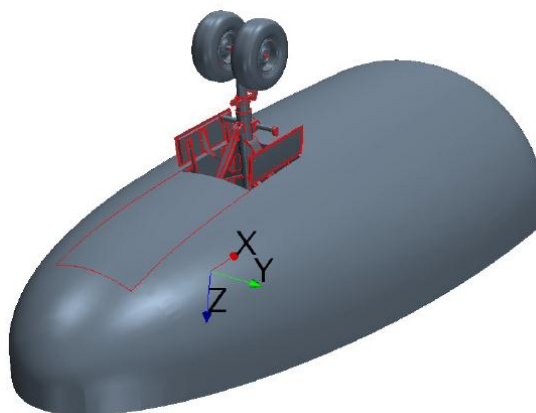
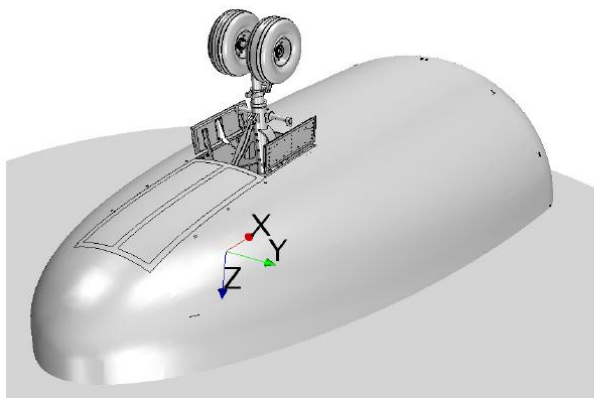

CFD and CAA Simulation (KTH)

CAD

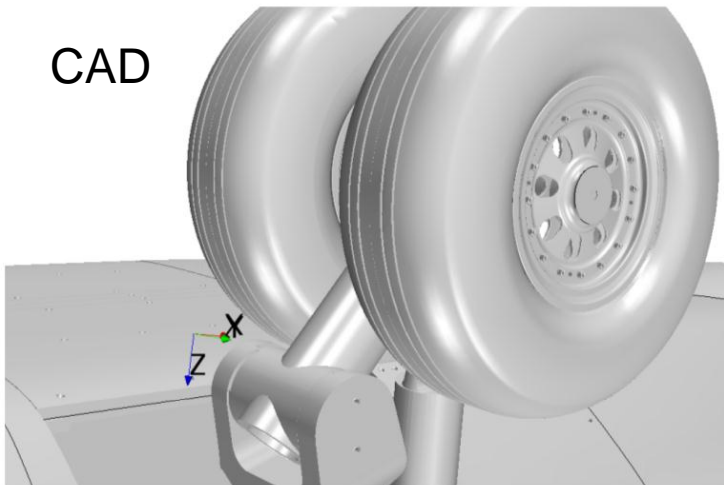

CFD

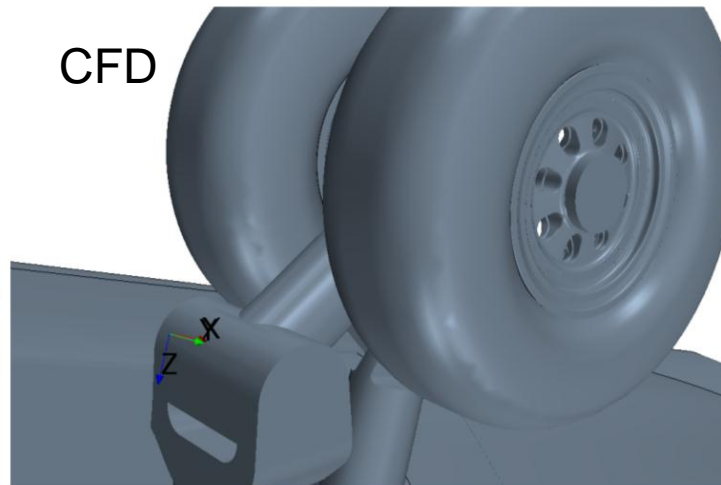

High fidelity
detailing of MLG
CAD retained for
CFD calculations

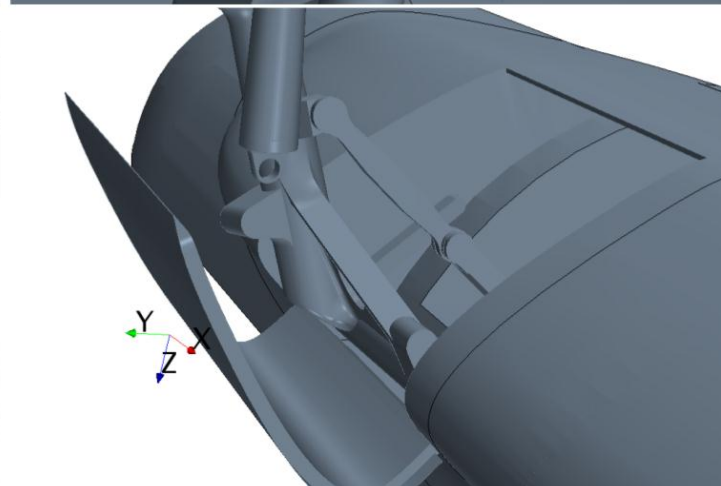
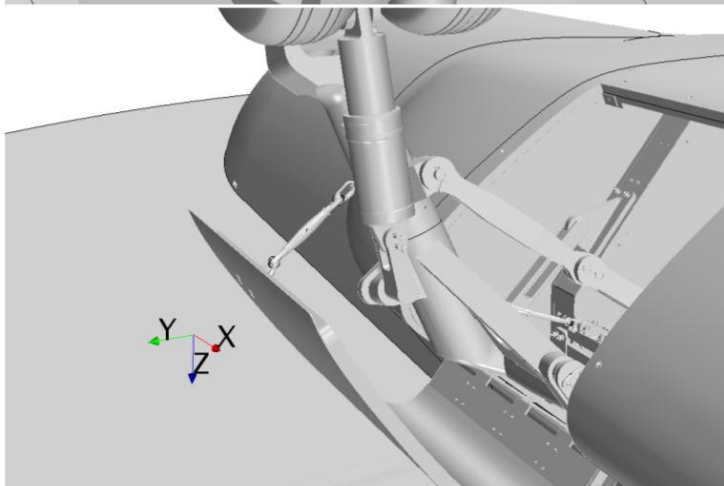

CFD and CAA Simulation (KTH)

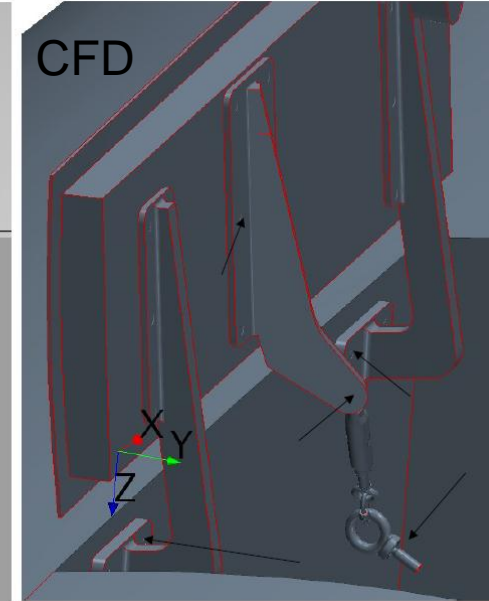
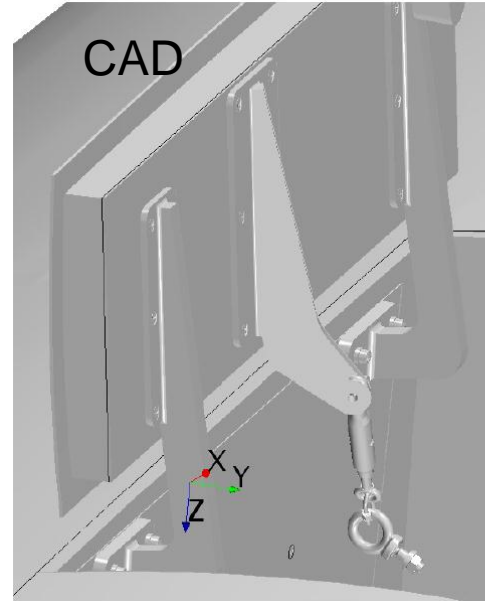
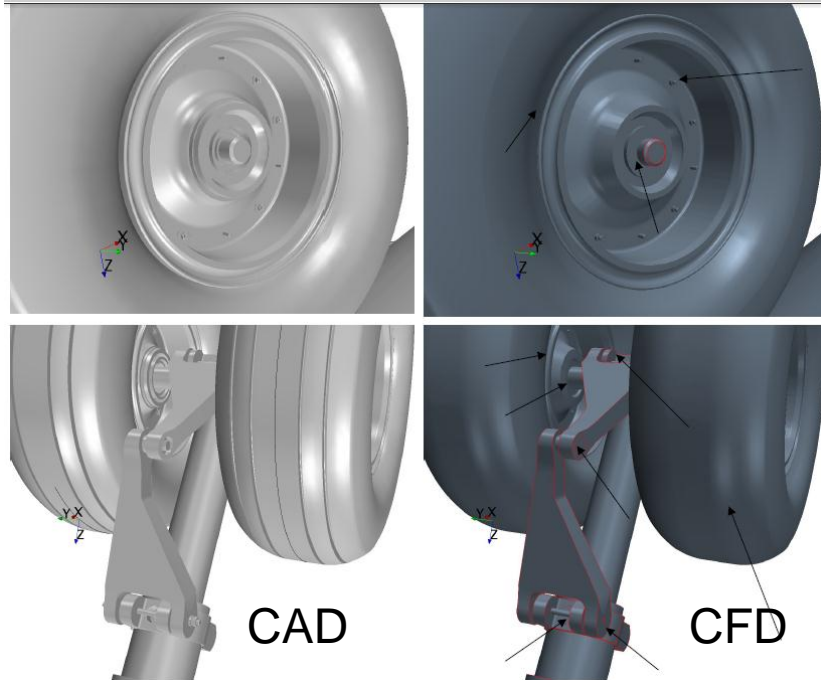

High fidelity detailing of NLG CAD retained for CFD calculations

CFD and CAA Simulation (KTH)

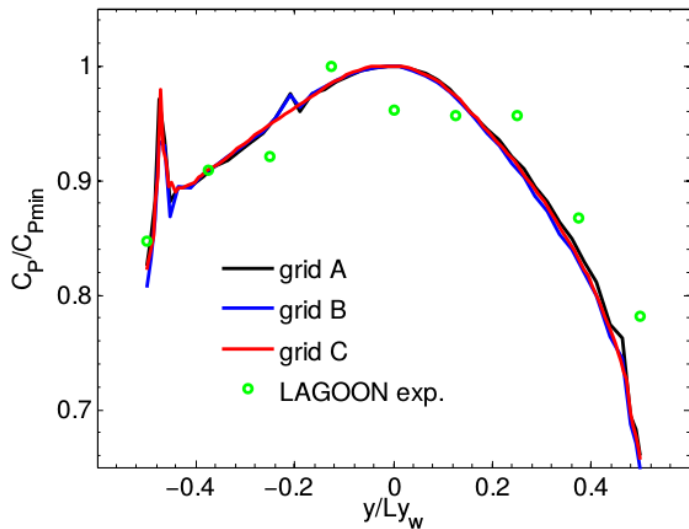
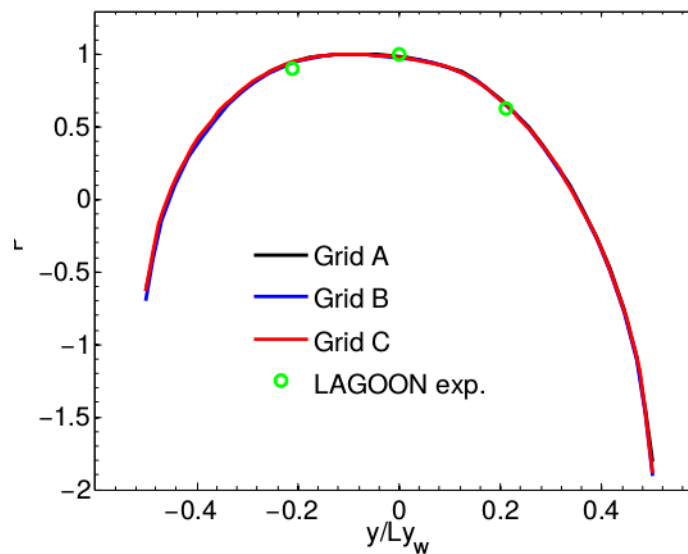
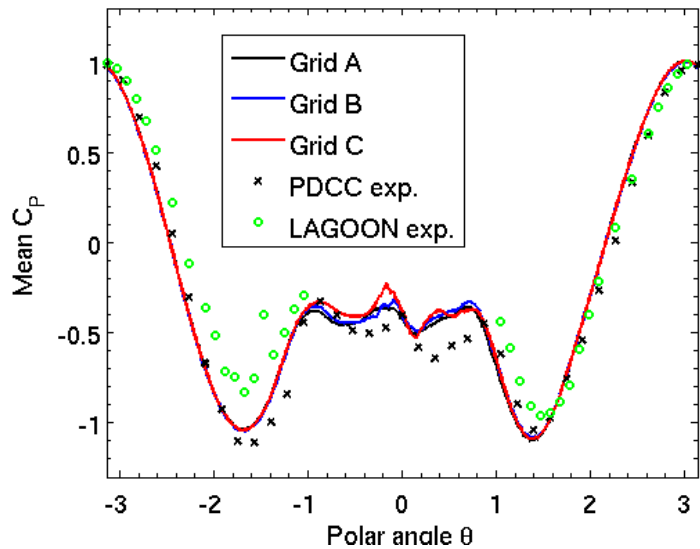

Comparison of surface pressure on the wheels with LAGOON and PDCC nose LGs.

CFD and CAA Simulation (KTH)

Instantaneous velocity for zero yaw, 50m/s, baseline case.

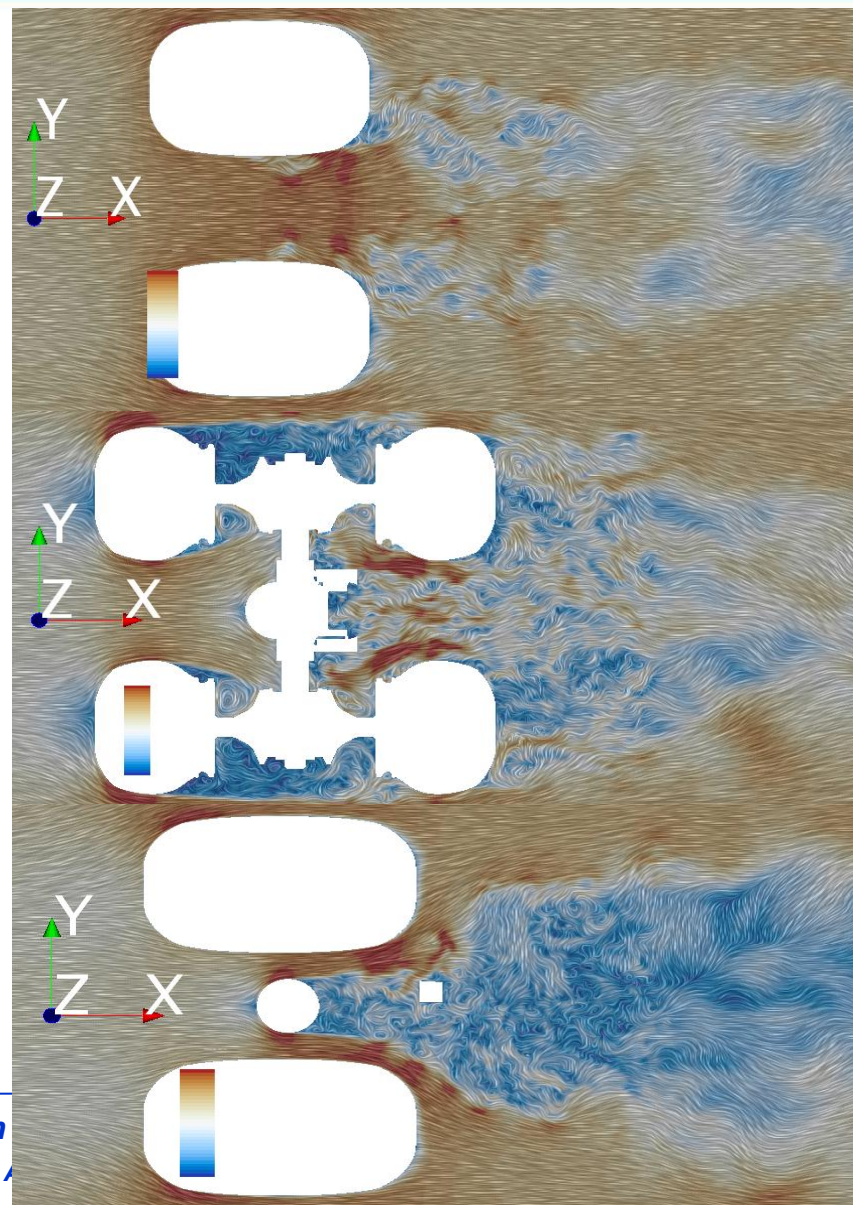
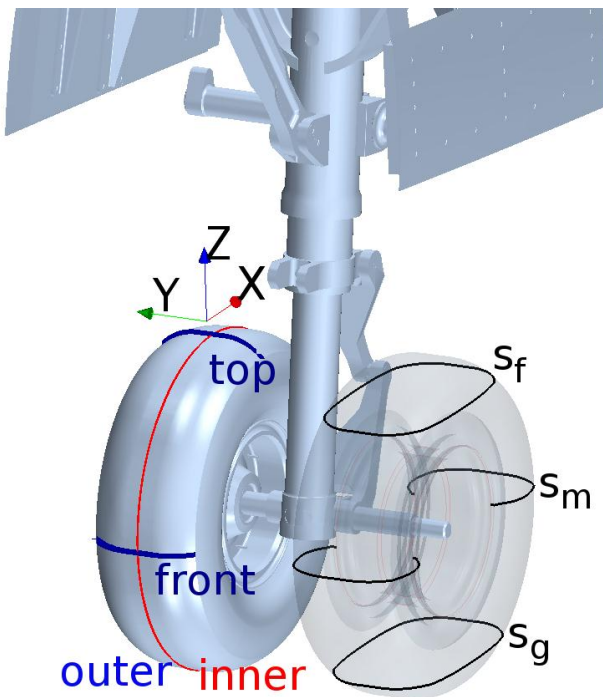

CFD and CAA Simulation (KTH)

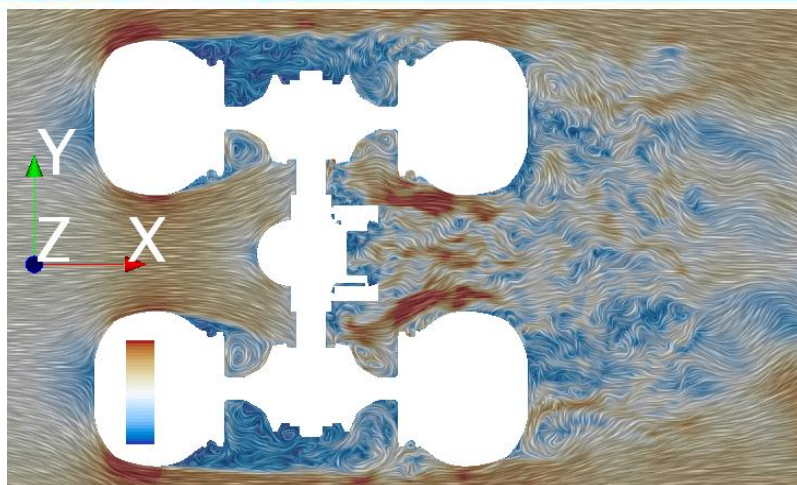

Baseline

NL3

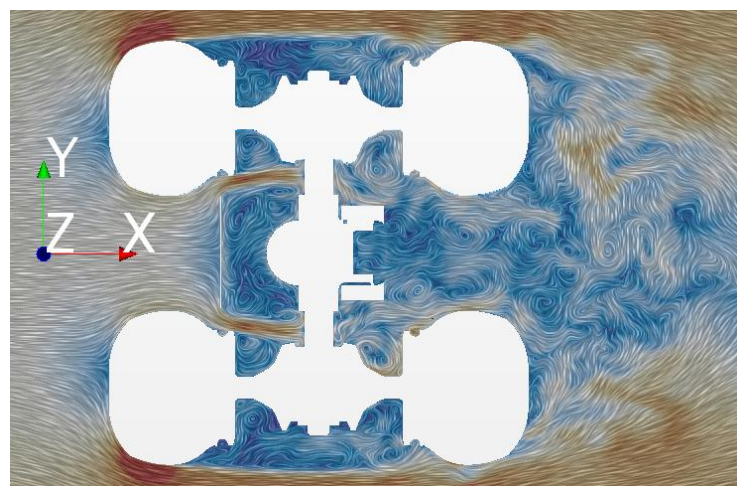
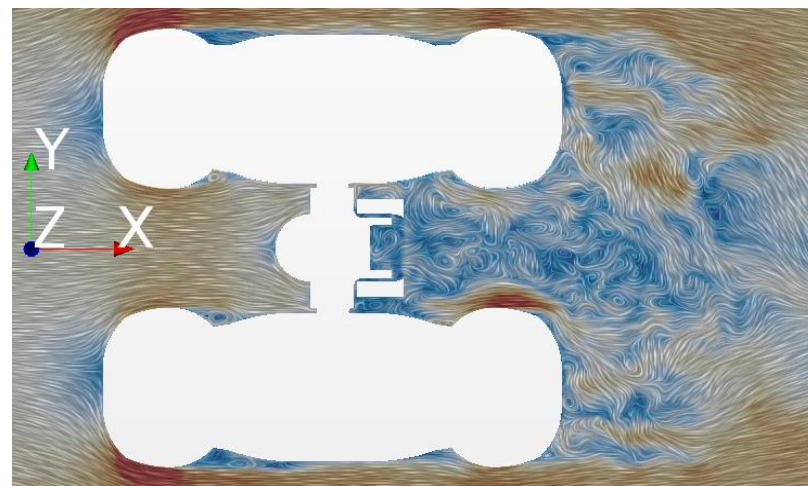

NL2

CFD and CAA Simulation (KTH)

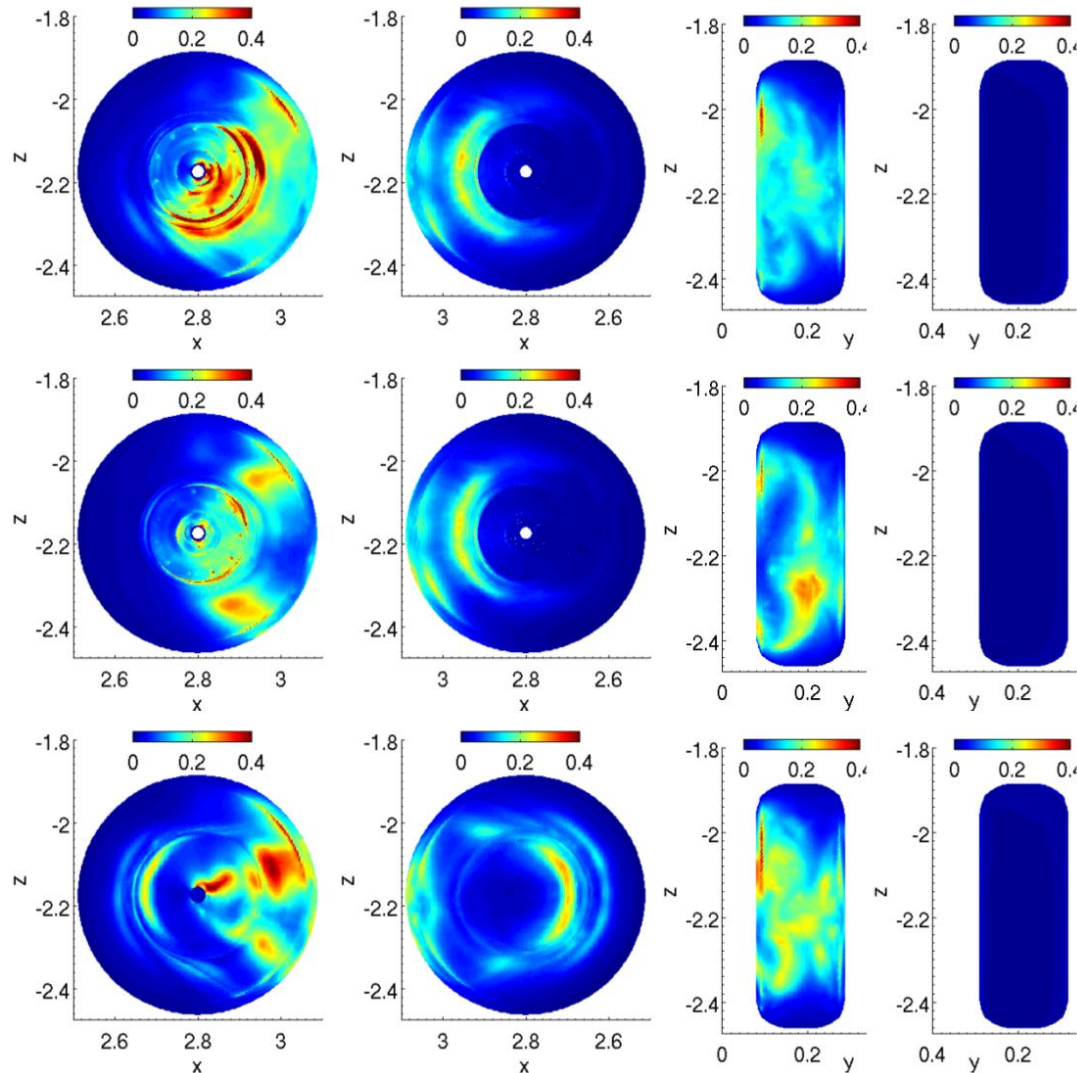

RMS surface pressure contours on wheel for baseline, LN2 and LN3

CFD and CAA Simulation (KTH)

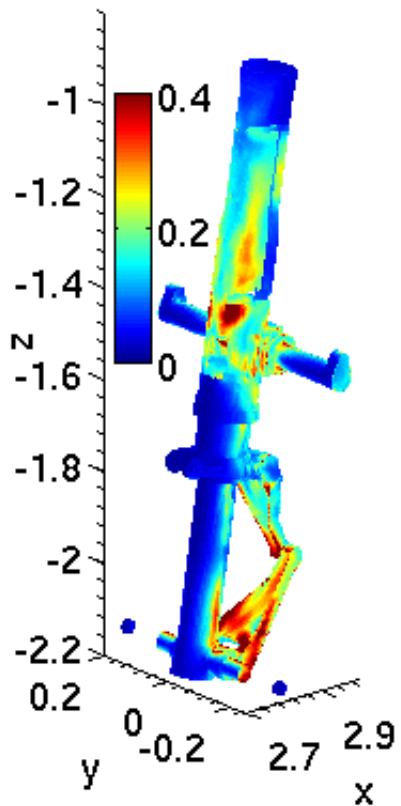

Baseline

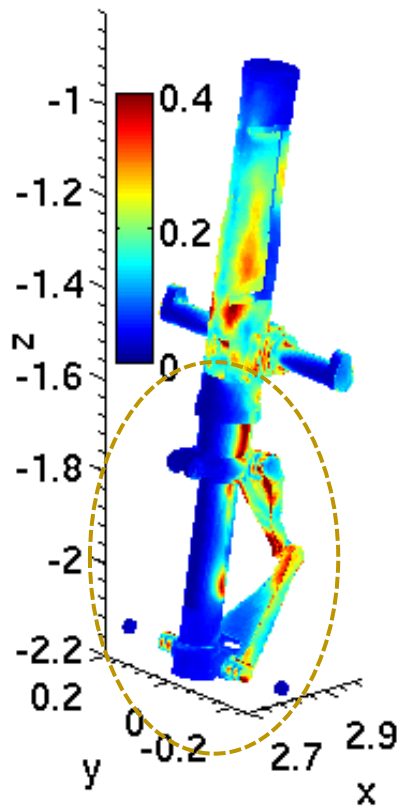

LN2

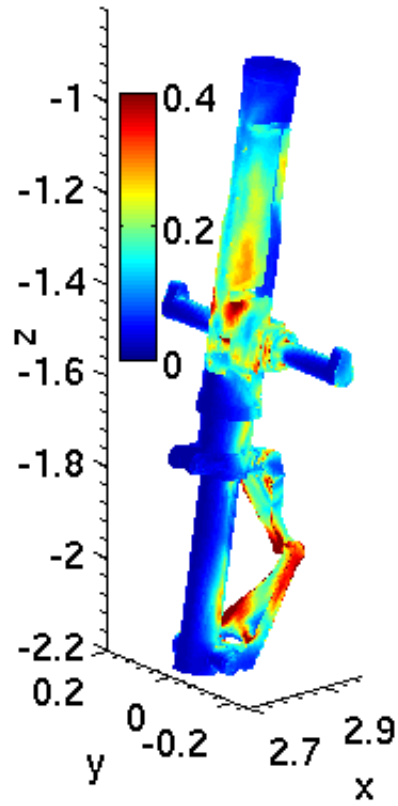

LN3

Reduced pressure fluctuations on the leg and torque links with LN2

CFD and CAA Simulation (KTH)

Impact of yaw angle on surface pressure fluctuations on door

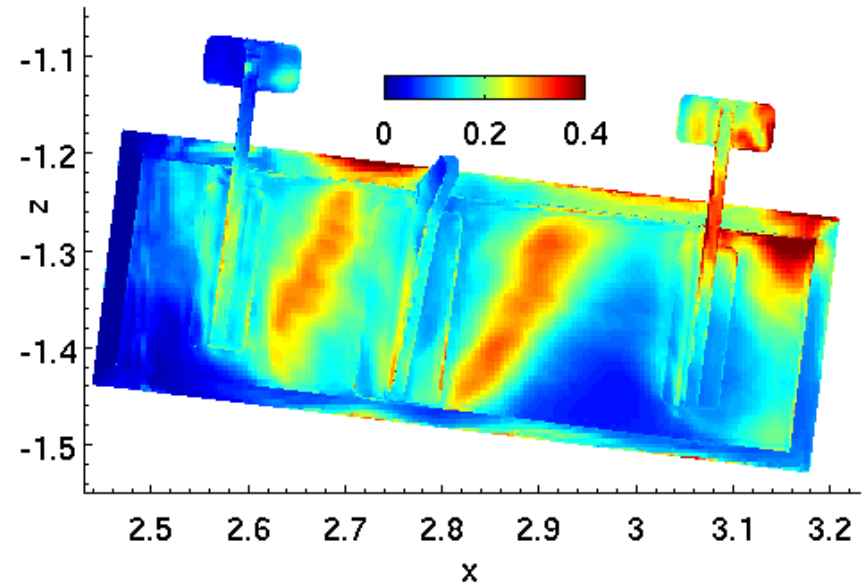
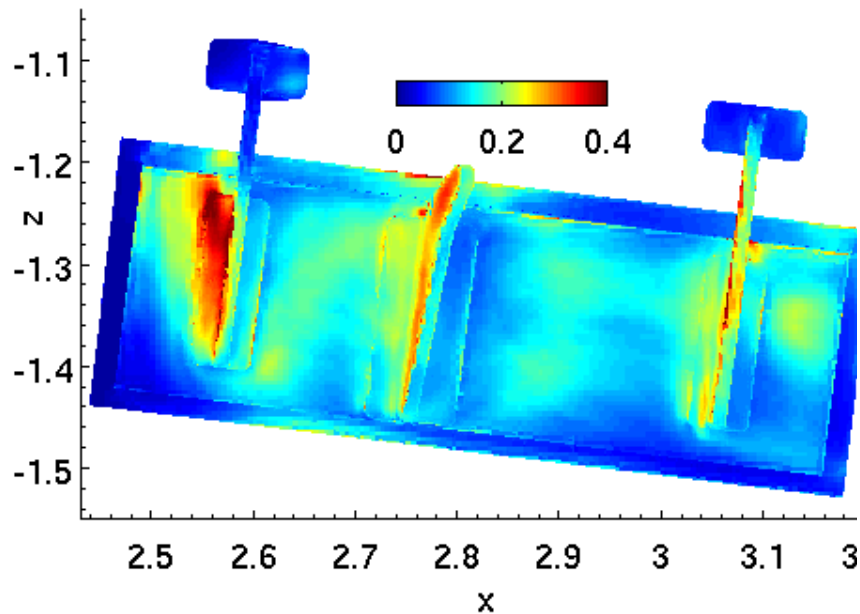

Reference $V=50\text{m/s}$, yaw angle =0 - Reference $V=50\text{m/s}$, yaw angle=10

Wind Tunnel Testing (Pininfarina, TCD, Eurotech)

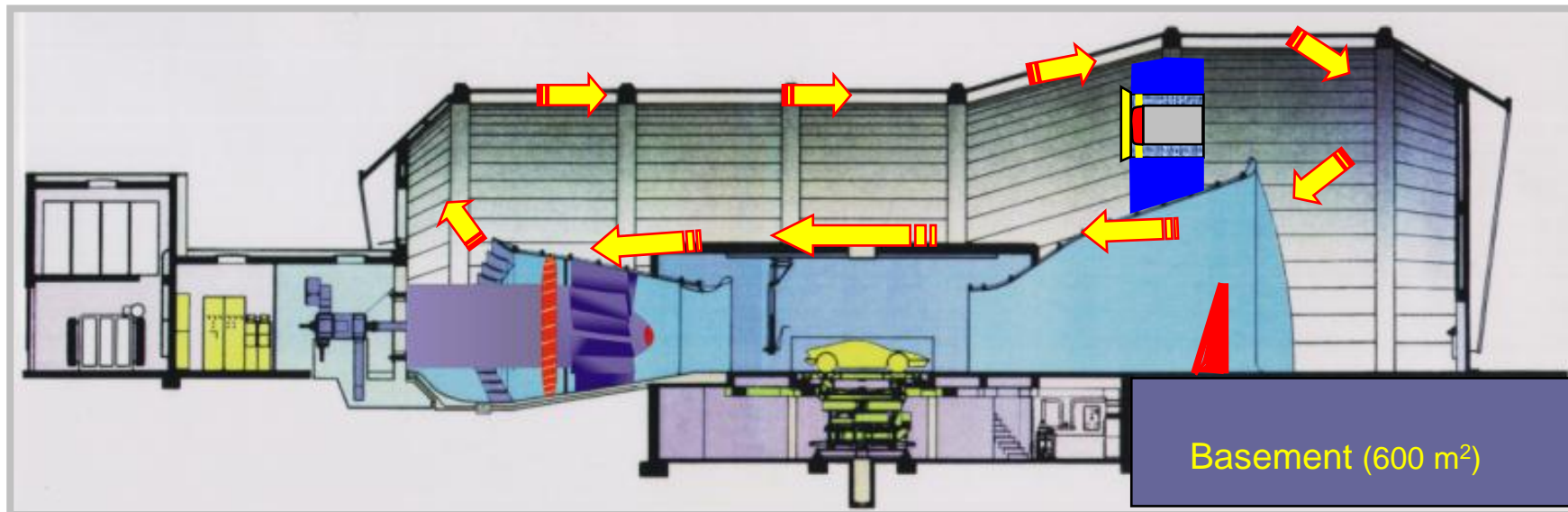

Jet Section	:	11 m ² (semi-circular)
Flow Max Velocity	:	260 km/h (*)
Background Noise Level	:	68 dBA at V = 100 km/h
Turbulence Intensity	:	0.3%
		(*) in empty test section

Wind Tunnel Testing (Pininfarina, TCD, Eurotech)

The Wind Tunnel was improved in two steps:

1. A new **Low-Noise Fan Drive System** (29 blades, low rpm) to reduce noise in the test section
2. An array of **13 Fans** in the return circuit to increase the wind speed

In this way it has been possible to:
 increase max speed up to 260 km/h
 reduce BNL to 68 dBA at 100 km/h

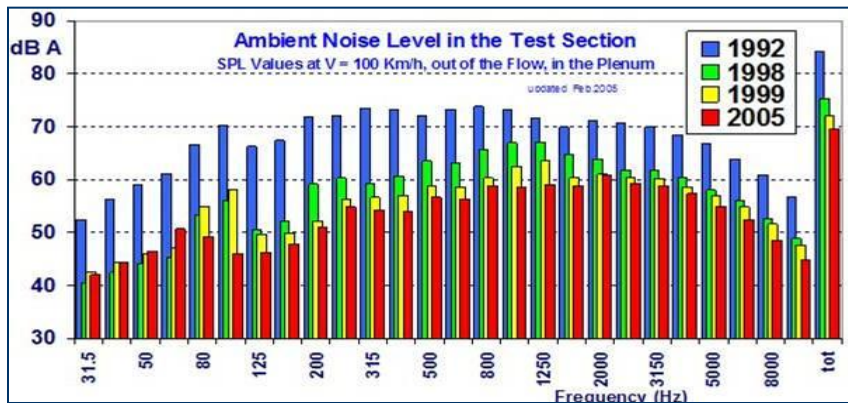

Reverberation Time (from 1992 to 2005)

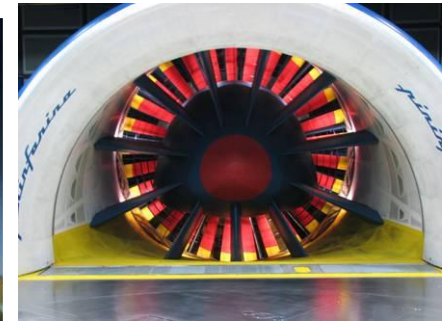
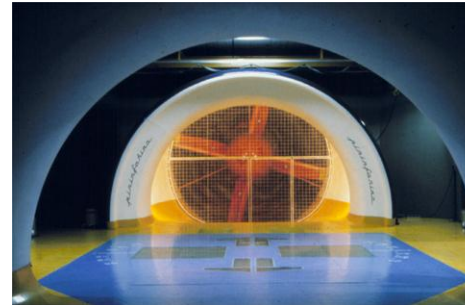
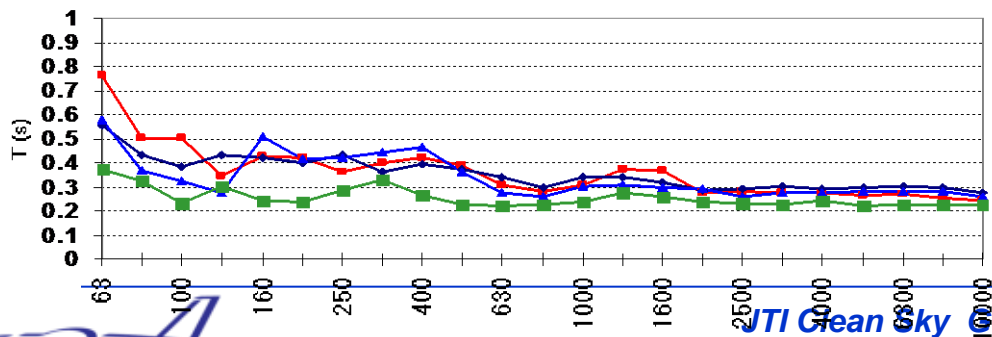

Wind Tunnel Testing (Pininfarina, TCD, Eurotech)

External noise is measured by:

- Linear FF Array 13 mic (B&K type 4189)
- 4 Surface Microphones (B&K type 4949)
- XZ Microphone Array 66 mic(Side Beamf)
- XY Microphone Array 78 mic (Top Beamf)

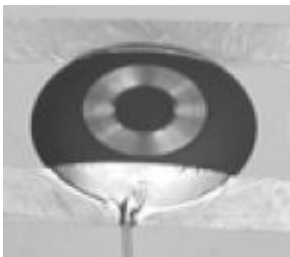

(B&K Type 4949)

Diameter of Housing	20 mm
Diameter of Diaphragm	11.3 mm
Height	2.51 mm
Sensitivity	11.2 mV/Pa
Frequency Range	5 • •20000 Hz
Dynamic Range	30 • •140 dB
Temperature	-30 • •100 ••C
Resonant Frequency of Diaphragm	24 kHz (90 ••Phase Shift)
Others	CCLD Preamplifier

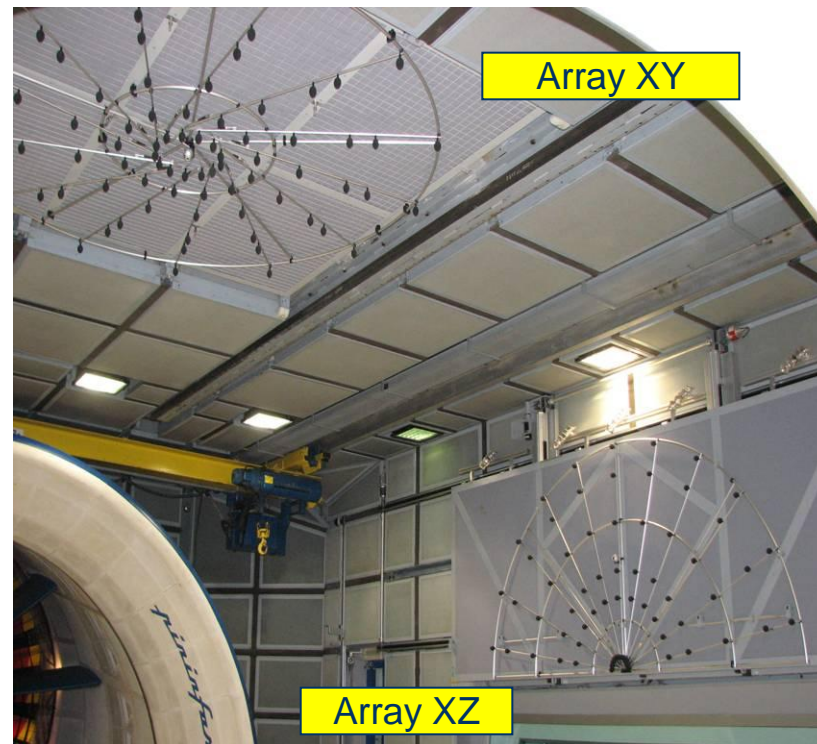

Wind Tunnel Testing (Pininfarina, TCD, Eurotech)

NLG TEST MODEL IN PININFARINA WIND TUNNEL FACILITY

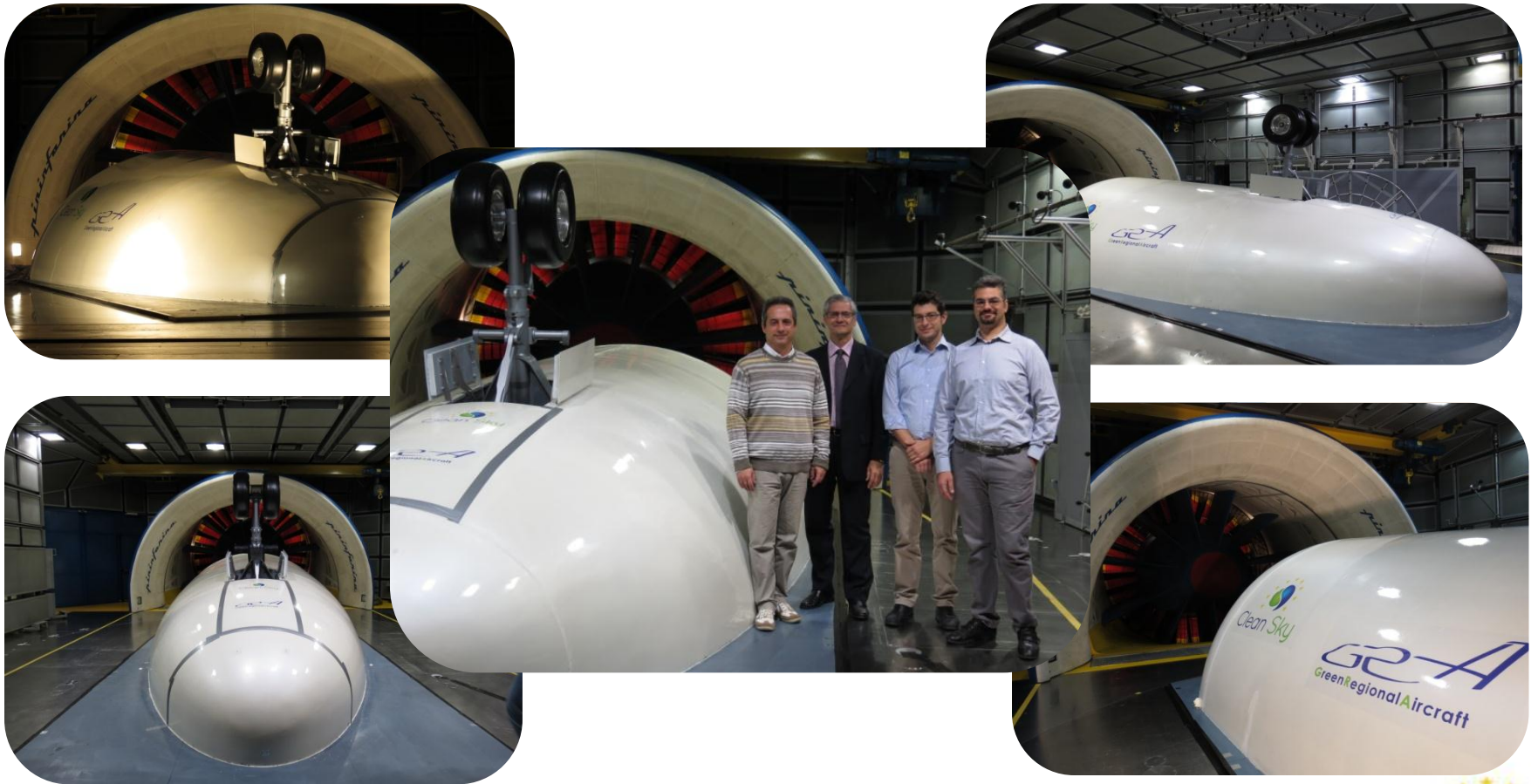

Wind Tunnel Testing (Pininfarina, TCD, Eurotech)

MLG TEST MODEL IN PININFARINA WIND TUNNEL FACILITY

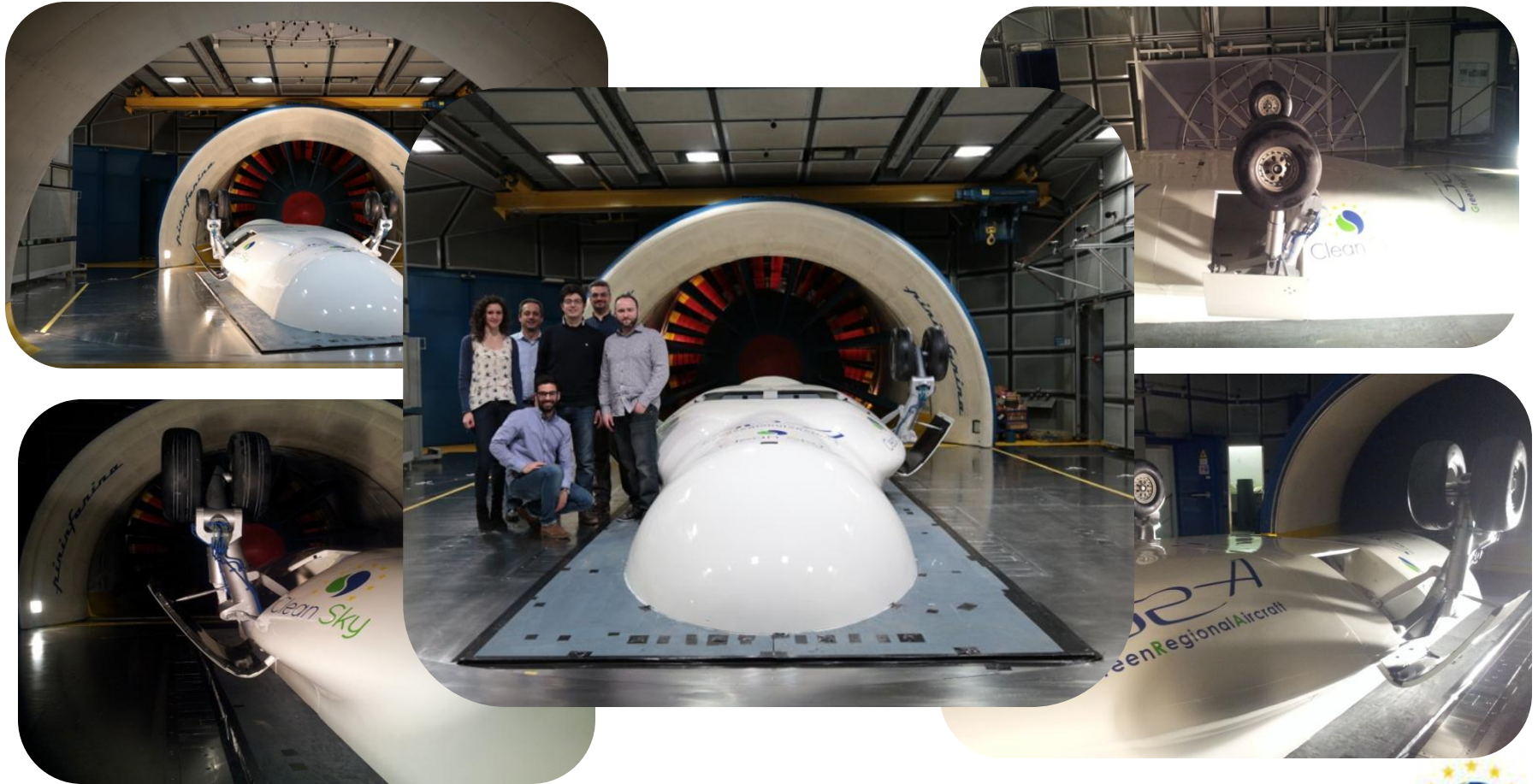

Wind Tunnel Test Data Analysis (TCD)

- Each model configuration was tested at a variety of flow speeds and yaw settings. The yaw settings allowed the performance of the technology to be evaluated under conditions equivalent to landing with a cross wind
- Datasets from all sensors were sampled at 32768 Hz for a time duration of 10 seconds
- Processed using 1/3 octave band analysis between 20 Hz and 10 kHz
- PNL and PNLT calculations
- Narrow band spectral analysis
- Beam forming source identification

40m/s	50m/s	60m/s	65m/s
-10°	-10°	-10°	
-5°	-5°	-5°	-5°
0°	0°	0°	0°
5°	5°	5°	5°
10°	10°	10°	
-10° to +10°			

Test ID	Description
NLF	Closed fuselage section representing landing gear retracted
NLU	Nose landing gear extended without hydraulic dressing
NLG	Nose landing gear extended with hydraulic dressing
NL1	Nose landing gear extended with door ramp spoiler
NL2	Nose landing gear extended with wheel pack wind shield
NL3	Nose landing gear extended with hydraulic dressing and inner and outer wheel hub caps applied.
NL4	Nose landing gear extended with perforated fairings
NL5	Nose landing gear extended with N2+N3+N4
NL6	Nose landing gear extended with N1+N2+N3

Wind Tunnel Test Data Analysis (TCD)

Test ID	Description	Ranking
NL1	Nose landing gear extended with door ramp spoiler	2nd
NL2	Nose landing gear extended with wheel pack wind shield	3rd
NL3	Nose landing gear extended with hydraulic dressing and inner and outer wheel hub caps applied.	4th
NL4	Nose landing gear extended with perforated fairings	6th
NL5	Nose landing gear extended with N2+N3+N4	5th
NL6	Nose landing gear extended with N1+N2+N3	1st

- The combination technology NL6 was the best performing noise low noise technology.
- This combination comprised of the best performing individual technologies.
- The strongest contribution to the noise reduction was generated by the NL1 ramp door fairing

Wind Tunnel Test Data Analysis (TCD)

Mic Number	x (m)	θ (°)
1	3.668	37.32
2	2.336	47.10
3	1.467	55.94
4	0.823	63.89
5	0.297	71.31
6	-0.166	78.43
7	-0.600	85.46
8	-1.034	92.63
9	-1.497	100.18
10	-2.023	108.33
11	-2.667	117.35
12	-3.536	127.53
13	-4.868	139.06

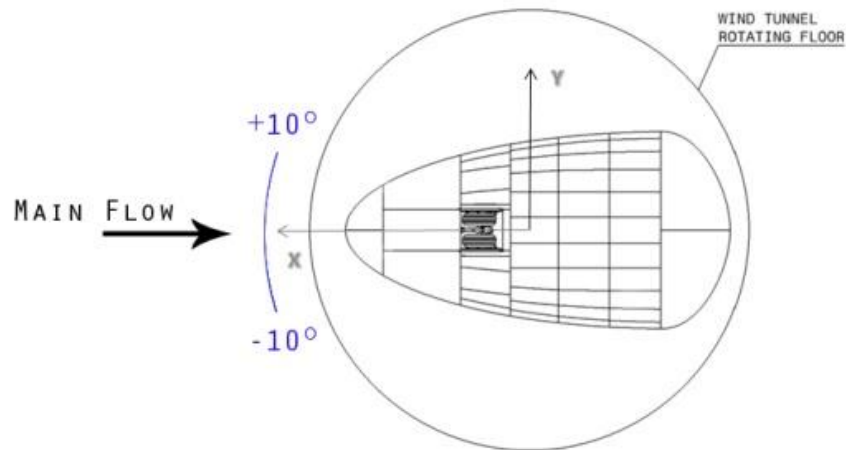
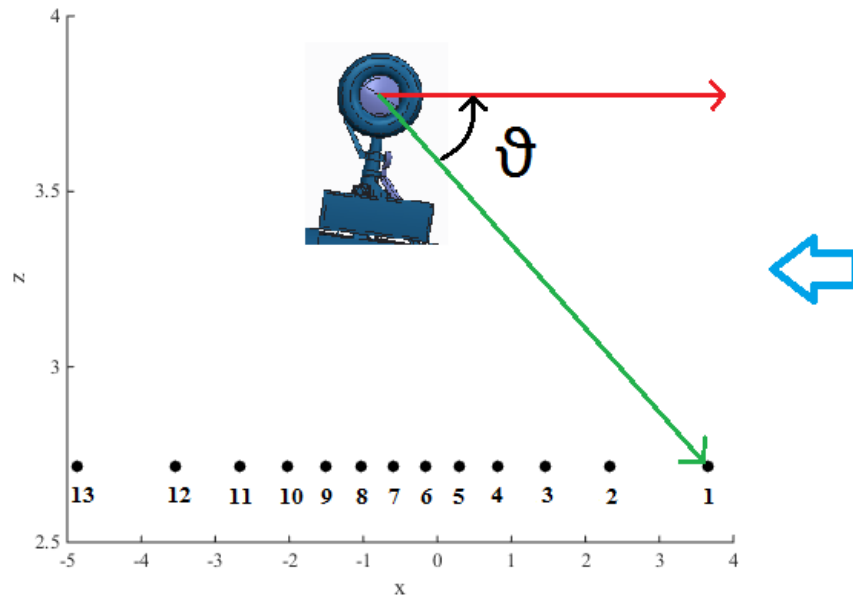

Wind Tunnel Test Data Analysis (TCD)

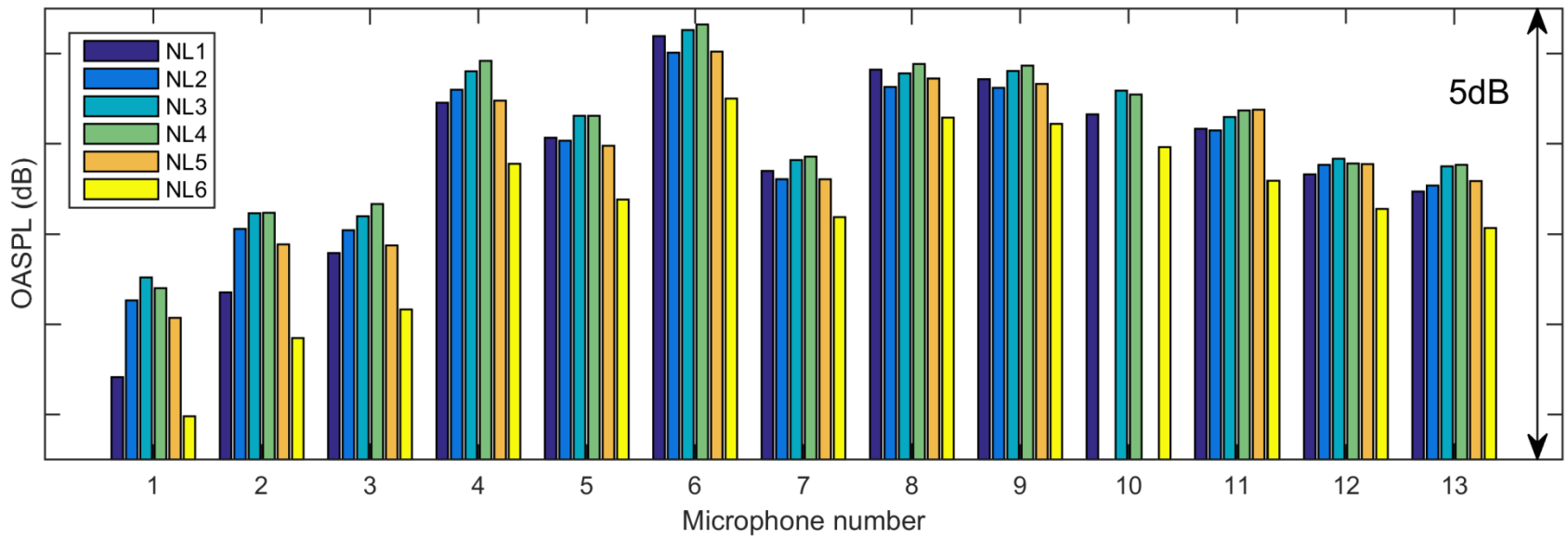
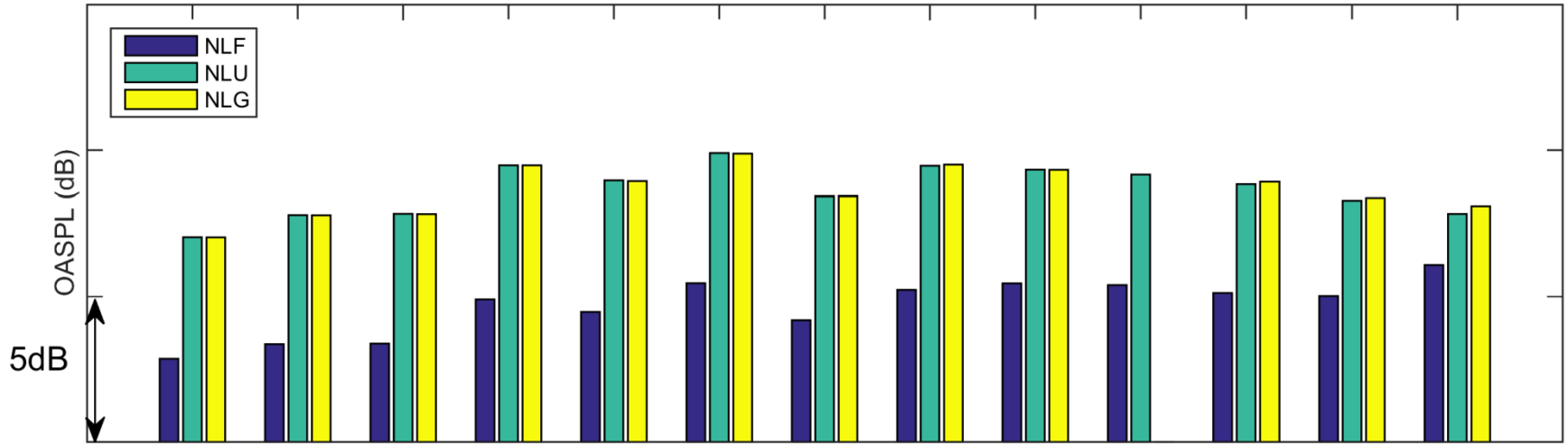

Wind Tunnel Test Data Analysis (TCD)

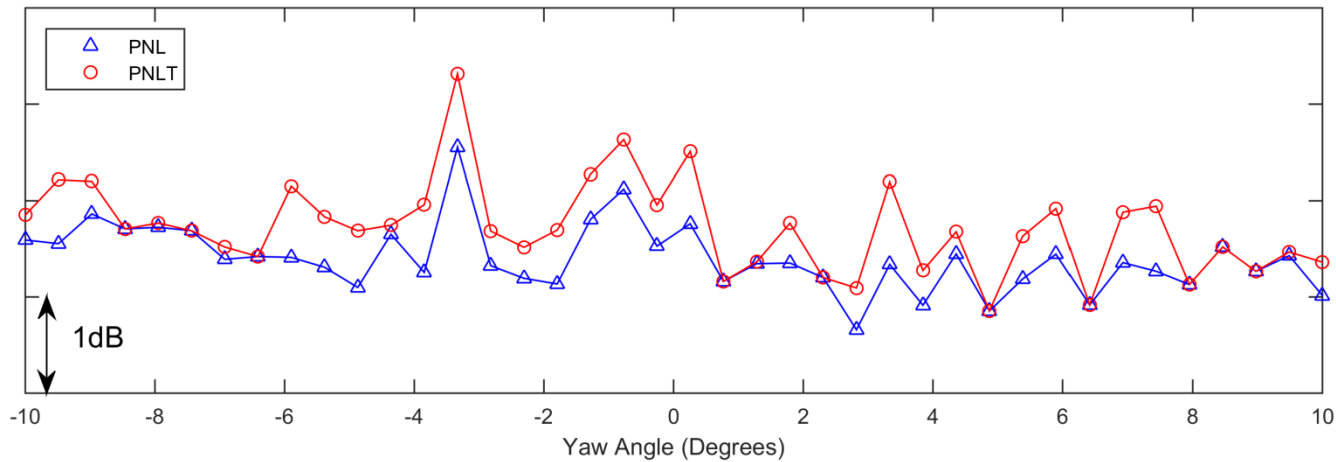
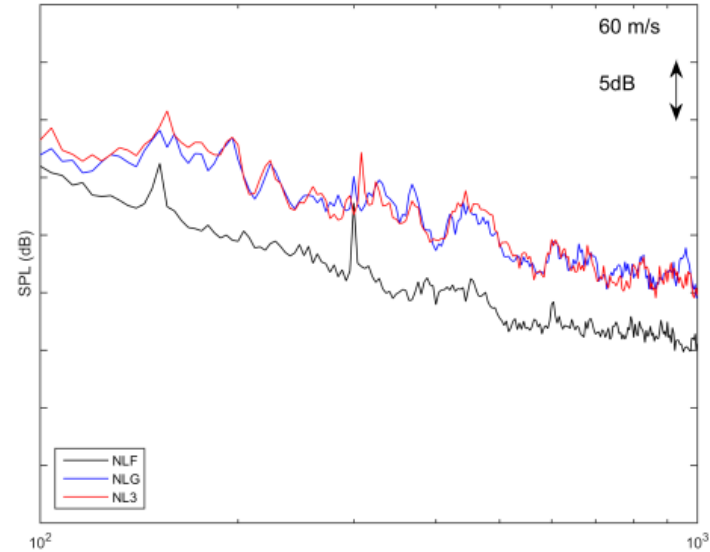
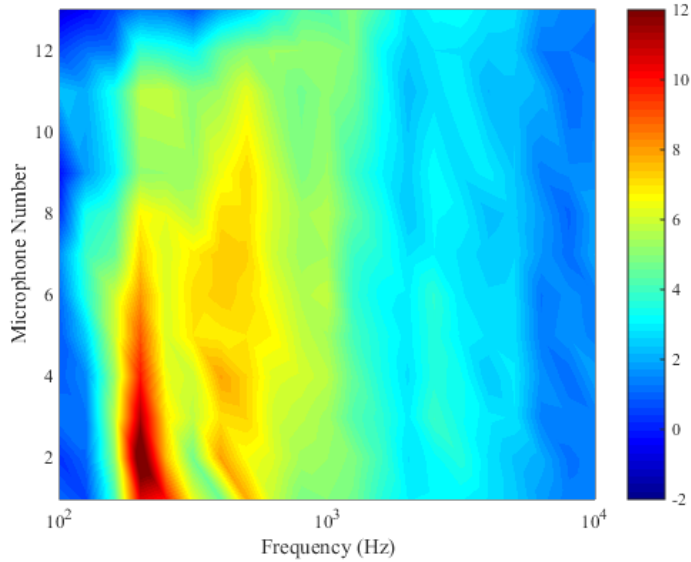

Wind Tunnel Test Data Analysis (TCD)

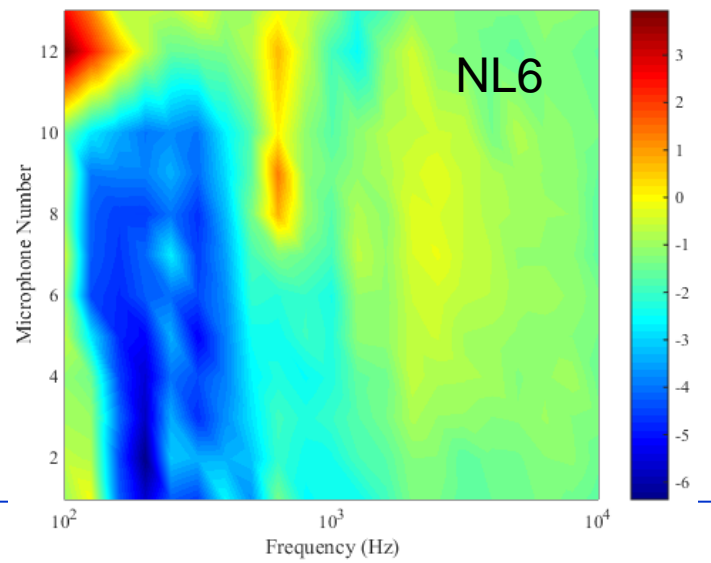
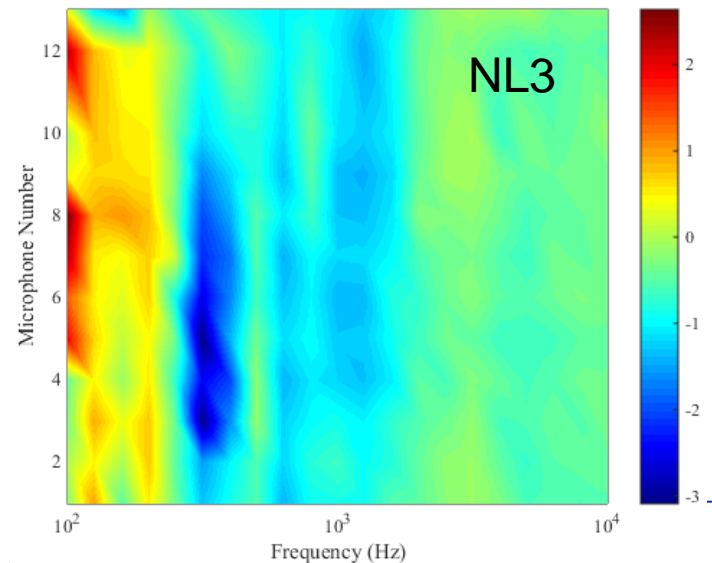
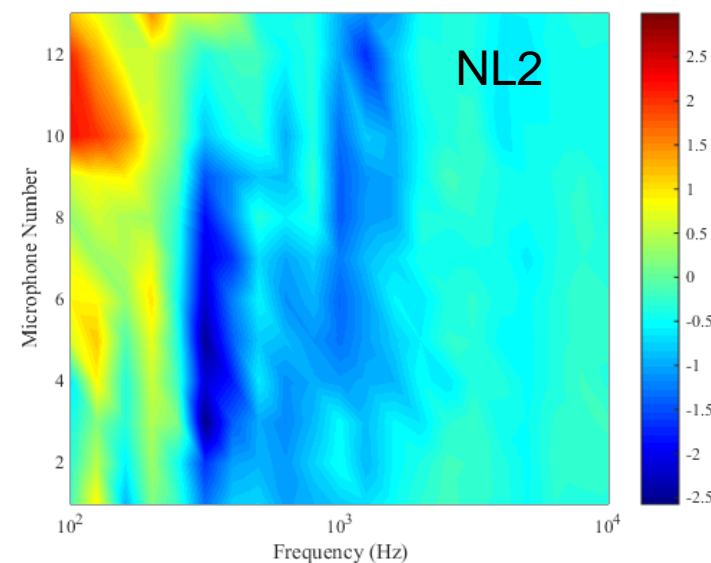
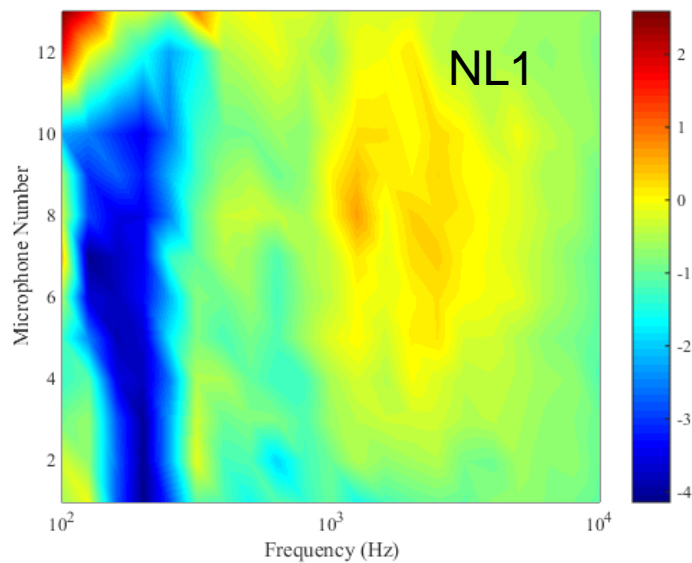

NL6 combined noise reductions at different frequency ranges from the different technologies

Wind Tunnel Test Data Analysis (TCD)

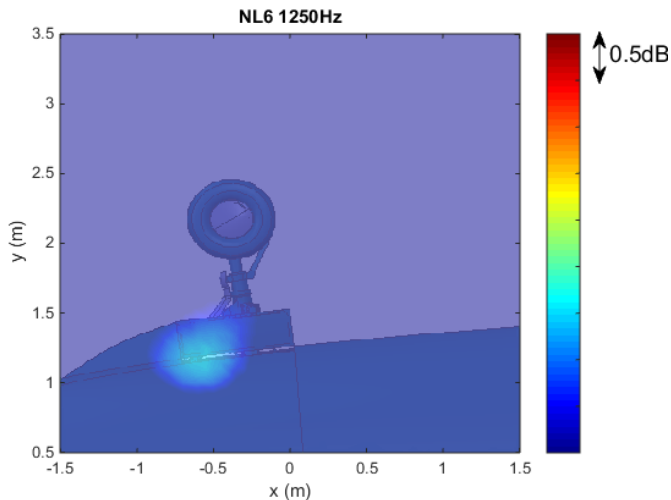
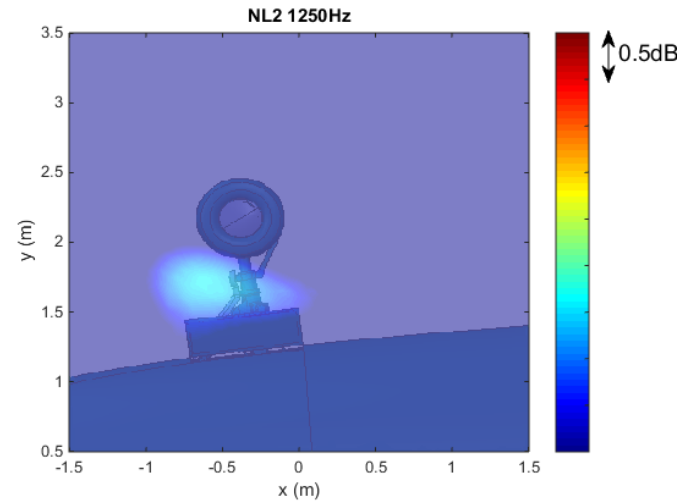
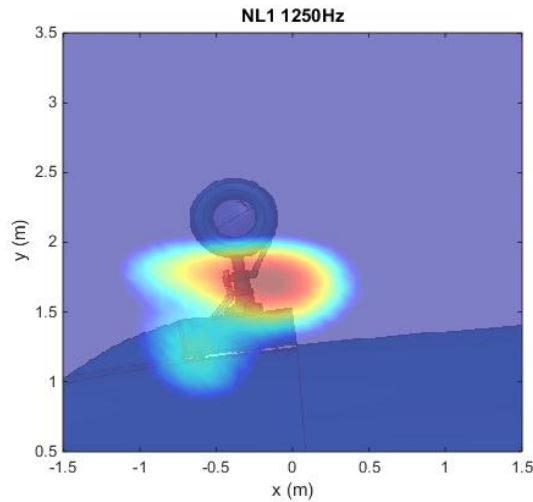
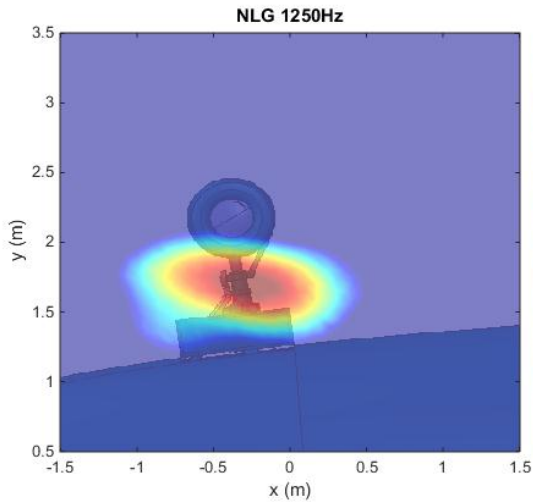

NL6 has effectively eliminated the original steering pinion and torque link source with a reduction of over 4dB. The strongest remaining noise source in this frequency band is now in the region of the intersection of the bay door and the door ramp fairing. Thus, NL6 can be seen as a combination of the beneficial effects of NL1, NL2 and NL3.

Wind Tunnel Test Data Analysis (TCD)

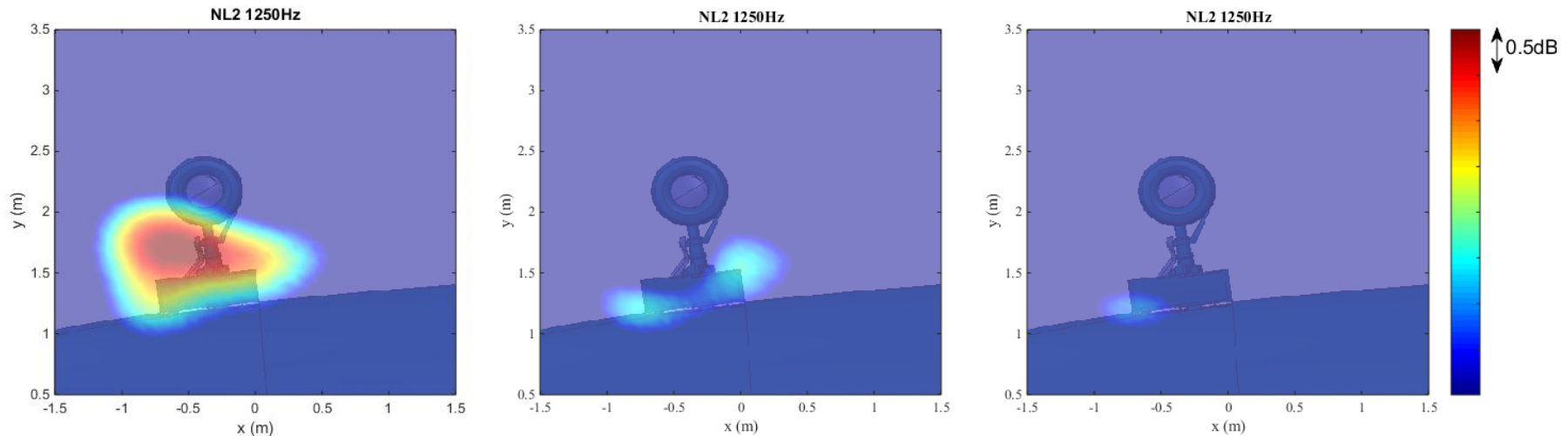

- Beam forming source deletion is a simple technique to reveal weaker sources by subtractive signal decomposition.
- Utilizing this approach for NL2 we can see the initial beamforming map has a distributed source with a peak covering the steering pinion and torque links.
- When this peak is removed the contribution of the door edges becomes clearer.
- A further iteration removes the contribution of the rear door edge and the front door edge noise source is the final remaining source.

Wind Tunnel Test Data Analysis (TCD)

- Each model configuration was tested at a variety of flow speeds and yaw settings. The yaw settings allowed the performance of the technology to be evaluated under conditions equivalent to landing with a cross wind
- Datasets from all sensors were sampled at 32768 Hz for a time duration of 10 seconds
- Processed using 1/3 octave band analysis between 20 Hz and 10 kHz
- PNL and PNLT calculations
- Narrow band spectral analysis
- Beam forming source identification

40m/s	50m/s	60m/s	65m/s
-10°	-10°	-10°	
-5°	-5°	-5°	-5°
0°	0°	0°	0°
5°	5°	5°	5°
10°	10°	10°	

Test ID	Description
MLF	Closed fuselage section representing landing gear retracted
MLU	Main landing gear extended without hydraulic dressing
MLG	Main landing gear extended with hydraulic dressing
ML4	Main landing gear extended with perforated fairings
ML5	Main landing gear extended with bay cavity absorber
ML7	Main landing gear extended with mesh treatment
ML8	Main landing gear extended with outer wheel hub caps and wheel axle fairing
FOB	Main landing gear extended with a fully open bay cavity

Wind Tunnel Test Data Analysis (TCD)

Test ID	Description	Ranking
ML4	Main landing gear extended with perforated fairings	3 rd
ML5	Main landing gear extended with bay cavity absorber	4 th
ML7	Main landing gear extended with mesh treatment	1 st
ML8	Main landing gear extended with outer wheel hub caps and wheel axle fairing	2 nd
FOB	Main landing gear extended with a fully open bay cavity	5 th

- The technology ML7, mesh treatment, was the best performing noise low noise technology.
- ML8 was almost equivalent in noise reduction
- ML5, the bay absorber treatment, achieved minimal noise reduction

Wind Tunnel Test Data Analysis (TCD)

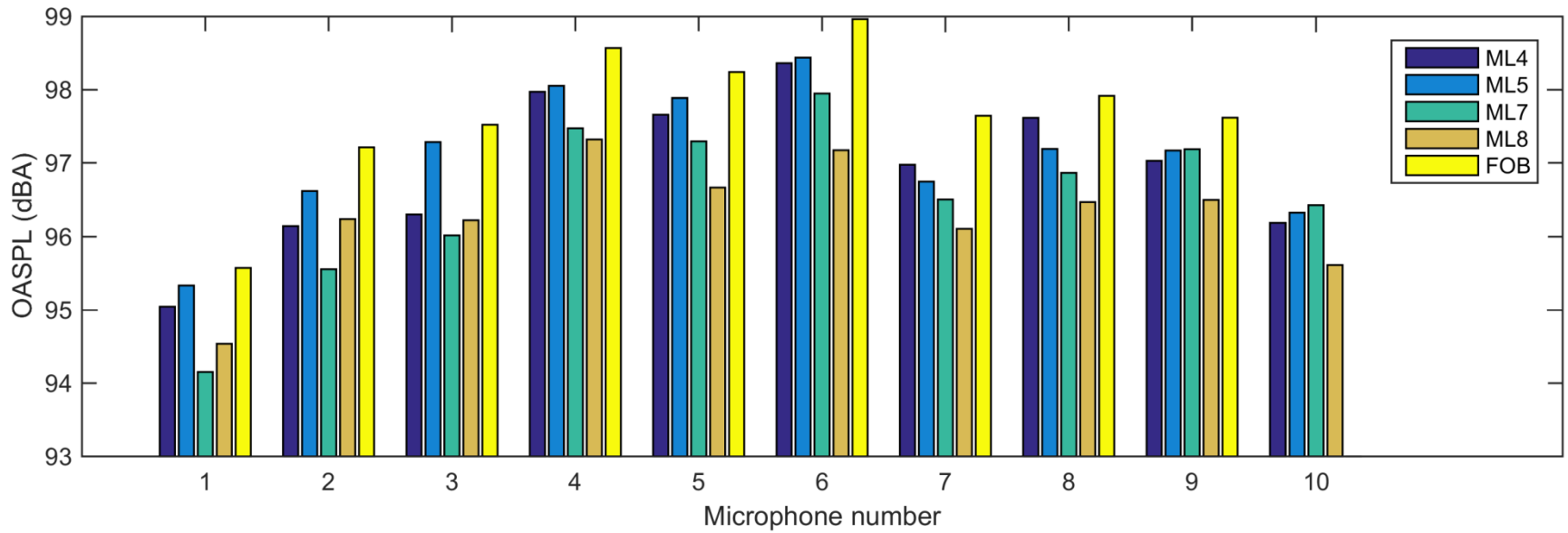
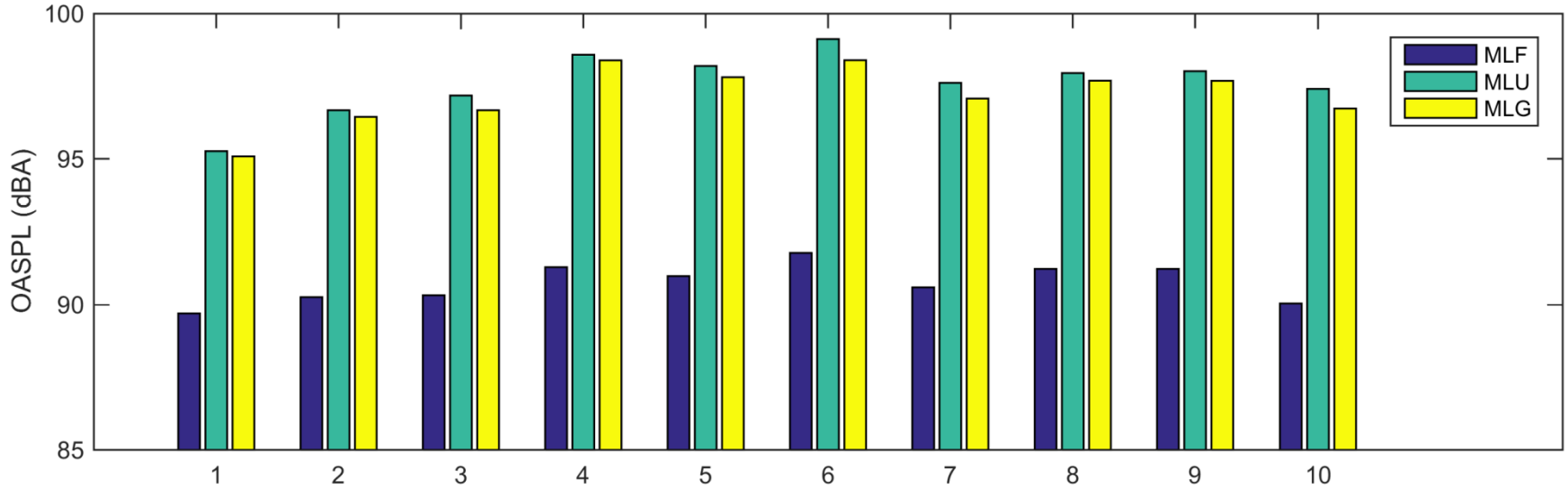

Wind Tunnel Test Data Analysis (TCD)

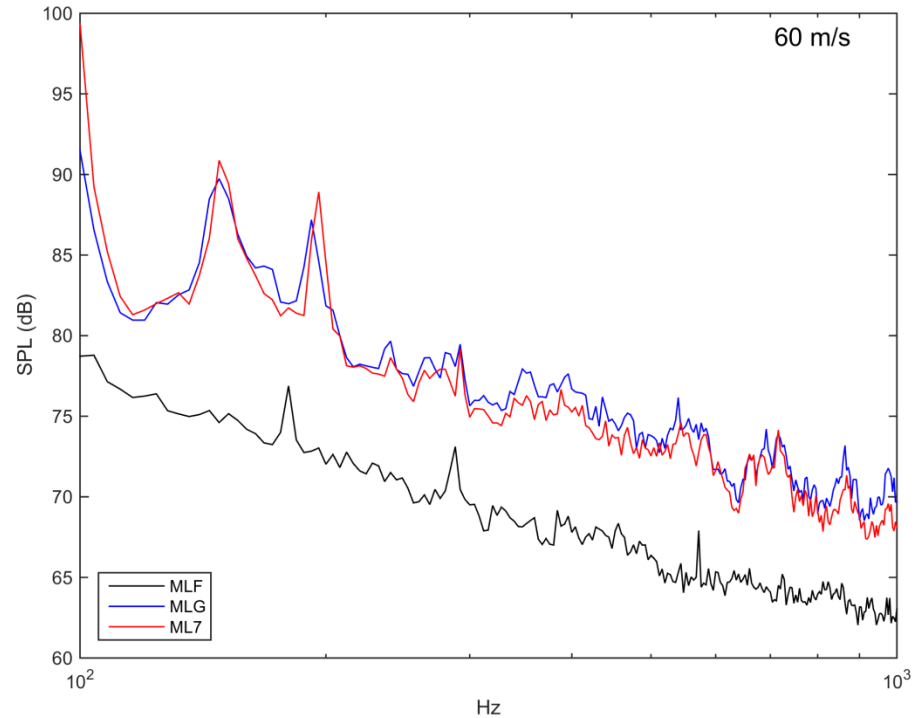
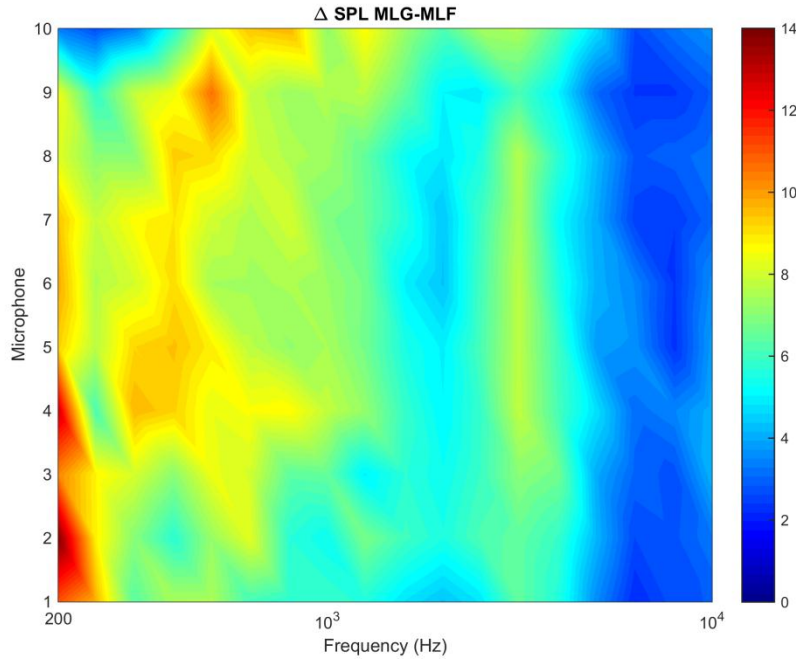

- The extended MLG generated noise up to 14 dB higher than the fuselage only background
- The effect of ML7 can be see as a broadband noise reduction

Wind Tunnel Test Data Analysis (TCD)

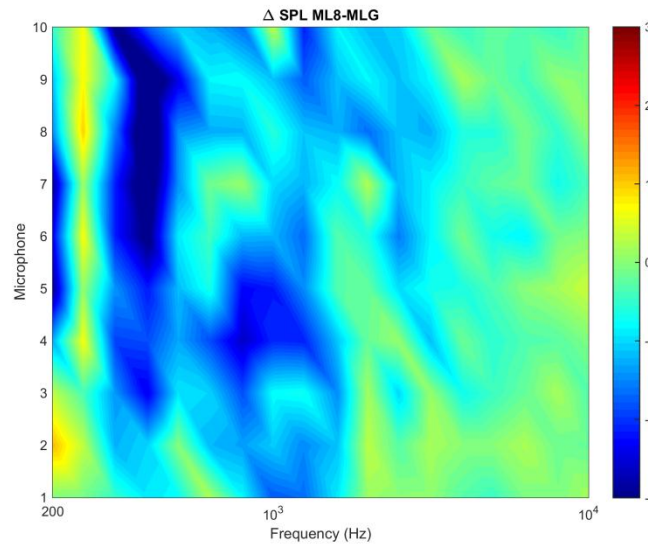
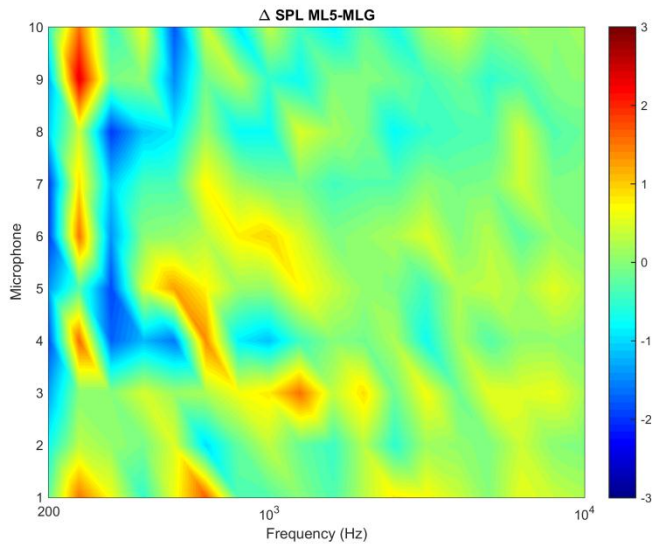
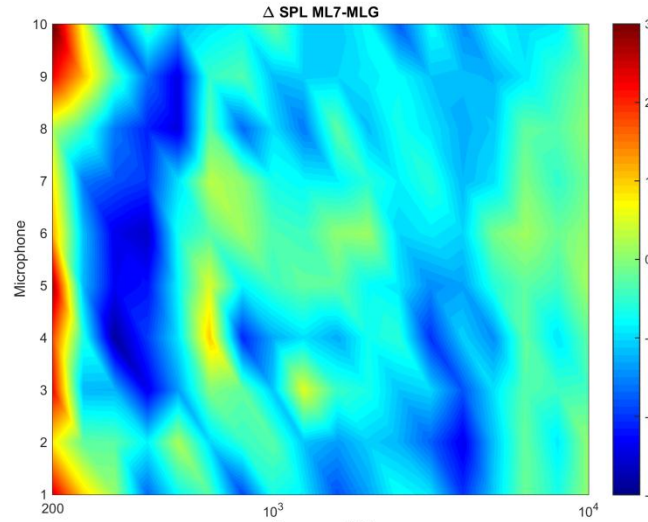
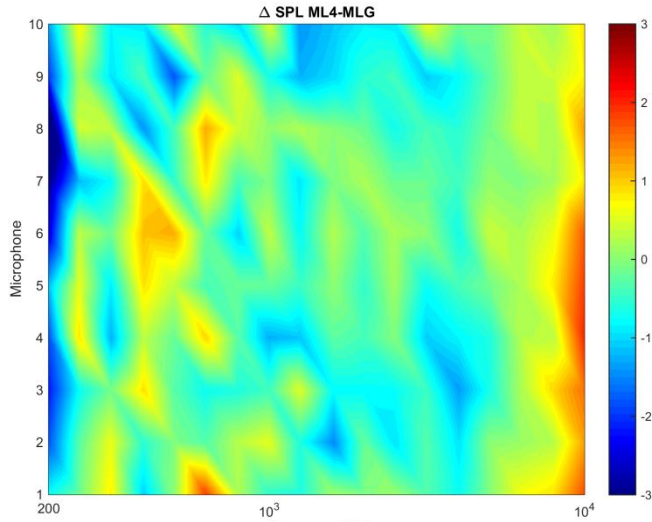

ML7 and ML8 achieve broadband noise reductions for all emission angles

Project Management (TCD)

No.	Milestone Name	Date DoW	Date Achieved / Scheduled
MS1	<i>Main Landing Gear Requirements</i>	M1	M5
MS2	<i>Preliminary Design Review</i>	M4	M15
MS3	<i>MLG low-noise configurations</i>	M12	M14
MS4	<i>Critical Design Review</i>	M16	M21
MS5	<i>Manufacturing review of MLG</i>	M19	M25
MS6	<i>Test Readiness Review</i>	M19	M25

Del. No.	NAME	DoW Date	Date Scheduled
D1.1	MLG low-noise preliminary solutions	M2	M6
D1.2	MLG low-noise solutions design	M5	M18
D1.3	Preliminary evaluation of MLG selected solutions	M9	M18
D1.4	CFD/CAA analyses of MLG baseline and low noise selected concept	M21	M26
D1.5	WT Test Matrix	M13	M22
D1.6	MLG model Requirements	M16	M19
D1.7	Executive Design of MLG of selected solution	M17	M18
D1.8	Test article hardware of MLG selected configurations	M19	M25
D1.9	MLG Wind Tunnel Test report	M21	M26
D1.10	Final Report	M24	M29

Project Management (TCD)

No.	Milestone Name	Date DoW	Date Achieved / Scheduled
MS7	<i>Nose Landing Gear Requirements</i>	M1	M5
MS8	<i>Preliminary Design Review</i>	M4	M15
MS9	<i>NLG low-noise configurations</i>	M12	M14
MS10	<i>Critical Design Review</i>	M16	M15
MS11	<i>Manufacturing review of NLG</i>	M19	M19
MS12	<i>Test Readiness Review</i>	M20	M22

Del. No.	NAME	DoW Date	Date Scheduled
D2.1	NLG low-noise preliminary solutions	M2	M6
D2.2	NLG low-noise solutions design	M5	M18
D2.3	Preliminary evaluation of NLG selected solutions	M9	M18
D2.4	CFD/CAA analyses of NLG baseline and low noise selected concept	M21	M26
D2.5	WT Test Matrix	M13	M19
D2.6	NLG model Requirements	M16	M18
D2.7	Executive Design of NLG of selected solution	M17	M18
D2.8	Test article hardware of NLG selected configurations	M19	M22
D2.9	NLG Wind Tunnel Test report	M21	M22
D2.10	Final Report	M24	M29

Project Dissemination

- ❖ Jeremy Dahan, Romain Futrzynski, Ciaran O'Reilly, Gunilla Efraimsson, *Aero-acoustic source analysis of landing gear noise via dynamic mode decomposition*, ICSV21, Beijing, China, July 13-17, 2014
- ❖ Jeremy Dahan, Ciaran O'Reilly, Gunilla Efraimsson, *Numerical Investigation of a Realistic Nose Landing Gear*, 20th AIAA/CEAS Aeroacoustics Conference, Atlanta, GA, 2014, (AIAA 2014-2077)
- ❖ Jeremy Dahan, Ciaran O'Reilly, Gunilla Efraimsson, *A numerical investigation of passive strategies for landing gear noise reduction*", AIAA /CEAS conference 2015
- ❖ Jeremy Dahan, Ciaran O'Reilly, Gunilla Efraimsson, *Numerical investigation of the flow around a detailed nose landing gear*, submitted
- ❖ Neri, E. Kennedy, J. Bennett, G., O'Reilly, C. Dahan, J., Esposito, M., Amoroso, F., Bianco, A., Massimiliano, B., 2015, *Characterization of low noise technologies applied to a full scale fuselage mounted nose landing gear*, Proceedings of the Internoise 2015/ASME NCAD Meeting, Internoise2015 August 9-12, San Francisco, California, USA
- ❖ Neri, E. Kennedy, J. Bennett, G., 2015, *Aeroacoustic source separation on a full scale nose landing gear featuring combinations of low noise technologies*, Proceedings of the Internoise 2015/ASME NCAD Meeting, Internoise2015 August 9-12, San Francisco, California, USA

Project Dissemination

- ❖ An article in the EU wide publication "European Energy Innovation"
 - ▶ [European Energy Innovation](#) (page 16)
- ❖ A deliberate campaign to disseminate our EU funded research in the national and international press.
 - ▶ [TCD webpage](#)
 - ▶ [The Irish Times, Thursday August 28th, 2014](#)
 - ▶ [Silicon Republic, Thursday August 28th, 2014](#)
 - ▶ [The Metro, Friday August 29th, 2014](#)
 - ▶ [The Herald, Friday August 29th, 2014](#)
 - ▶ [The Journal, Friday August 29th, 2014](#)
 - ▶ [The University Times, Friday August 29th, 2014](#)
 - ▶ [Research And Innovation, Friday August 29th, 2014](#)
 - ▶ [Environment And Energy Management, Friday August 29th, 2014](#)
 - ▶ [Physorg: Trinity engineers design next-gen aircraft to reduce noise and carbon footprint](#)
 - ▶ [International Business Times – Australia: EU Initiative For Eco Friendly Green Regional Aircraft Taking Wings At Ireland](#)
 - ▶ [Cleansky Newsletter](#)

ALLEGRA – Contact Details

**Project Coordinator:
Trinity College Dublin**

Dr. Gareth Bennett
gareth.bennett@tcd.ie

ALLEGRA Consortium
Trinity College Dublin – Ireland
Royal Institute of Technology – Sweden
Magnaghi – Italy
PininFarina – Italy
Tecknosud – Italy
Eurotech - Italy

