

# 1 Final publishable summary report SCARLET

## 1.1 Executive summary

The SCARLET (*Scale-up of Calcium Carbonate Looping Technology for Efficient CO<sub>2</sub> Capture from Power and Industrial Plants*) project is a large and ambitious project to investigate one of the most promising post-combustion CO<sub>2</sub> capture technologies, Calcium Carbonate Looping (CCL). The CCL technology combines low CO<sub>2</sub> avoidance costs and efficiency penalties with a low environmental impact and the possibility of retrofit for any fossil fired flue gas source. This project focuses on bringing the CCL technology the next step towards maturity.

Results from four long-term CaL test campaigns carried out in the 1 MW<sub>th</sub> pilot plant at Technische Universität Darmstadt provide a reliable data base for process scale-up to industrial size. The experimental tests were particularly focused on the long-term sorbent reactivity in realistic operating to gain reliable information about the sorbent performance using hard coal either in pulverized and coarse form as well as pulverized or grained lignite, respectively. During these test campaigns, different sorbents with different chemical compositions and particle size distributions were utilized. During steady-state operation, CO<sub>2</sub> absorption rates in the carbonator higher than 90 % and overall CO<sub>2</sub> capture rates higher than 95 % were proven under a wide range of parameters, e.g. fuel characteristics in the calciner, solid circulation rates, make-up rate etc. Steady-state operation decarbonizing the flue gas of a 1 MW<sub>th</sub> coal fired furnace was investigated during 2,400 operating hours of the pilot, thereof more than 1,200 hours with continuous CCL operation.

For a scale-up of the CCL technology from 1 to 20 MW<sub>th</sub> and finally to 600-100 MW<sub>el</sub>, reliable design tools to model the whole system were developed and validated against experimental data from long-term pilot testing. Therefore, steady-state and dynamic process models for heat and mass balancing were developed and validated against the experimental data to predict the performance of up-scaled plants. Three-dimensional computational fluid dynamic (CFD) models based on different approaches for detailed reactor investigations and optimizations were investigated.

As the subsequent step towards commercialization of the CCL technology, a scale-up of the process to a 20 MW<sub>th</sub> pilot plant was carried. The work has been supported by the experimental data in 1 MW<sub>th</sub> scale and the developed scale-up tools. The design and engineering of reactors and all required auxiliary systems were based process configuration was defined based on heat and mass balances created for various load cases. The design and operational performance of the reactors were confirmed by CFD simulation with different model approaches. The investment cost (CAPEX) and operational cost (OPEX) were estimation. A detailed measurement plan was elaborated to validate the process in the scaled-up pilot plant. Furthermore, the operating procedures were defined describing the control strategy for various operating conditions. The Balance of Plant and the permitting process for erection and operation was prepared including a detailed plan for operation and logistics. Health, safety, environment (HSE) and technical risk assessment have identified no risks that would be considered unmanageable.

The thermodynamic, economic and environmental analyses for various host power and industrial plants based on the validated process model show the great advantages of CCL retrofit in terms of energy penalty, CO<sub>2</sub> avoidance costs and environmental impact. A net efficiency loss including CO<sub>2</sub> compression in a range of 6-7 %-points (including CO<sub>2</sub> compression) for hard coal and lignite fired power plants combined with very competitive CO<sub>2</sub> avoidance costs of 20-27 €/per tonne CO<sub>2</sub> show substantial advantages compared to other carbon capture technologies. Life cycle assessments conclude that the environmental burden of host power and industrial plants can be significantly reduced by a CCL retrofit.

## 1.2 Summary description of project context and objectives

Calcium carbonate looping (CCL) is a promising 2<sup>nd</sup> generation technology for low-cost post combustion CO<sub>2</sub> capture for fossil fuels which has recently been tested in pilot scale. Previous assessments of the CCL process propose a low efficiency penalty (including CO<sub>2</sub> compression) and low CO<sub>2</sub> avoidance costs, i.e. far below that of 1<sup>st</sup> generation capture processes, but were mainly based on thermogravimetric data and lab-scale experiments. The principle of CCL follows the scheme of Figure 1.

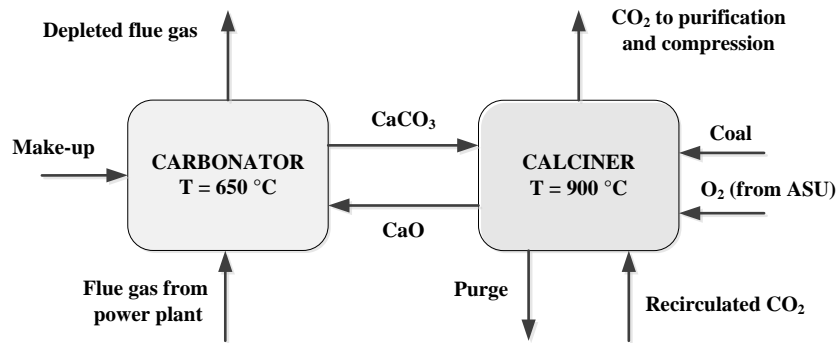

Figure 1: Basic principle of calcium carbonate looping

After the flue gas stream has been cleaned by conventional pollution control equipment (e.g desulphurization), the CO<sub>2</sub> in the flue gas is absorbed by CaO in a fluidized bed reactor operating at temperatures of about 650 °C. As the CaO is carbonated by the CO<sub>2</sub> in the flue gas, CaCO<sub>3</sub> is formed in an exothermic reaction. The CaCO<sub>3</sub> is then fed to a calciner where, at temperatures above 900 °C, the CO<sub>2</sub> is released through an endothermic reaction, and CaO is transported back to the carbonator. The calciner is also a fluidized bed type reactor. Fuel is burned with oxygen in the calciner to supply the heat needed for the calcination reaction of the CaCO<sub>3</sub> and to obtain a CO<sub>2</sub>-rich stream at the calciner outlet.

As this carbon capture process operates at very high temperatures, the heat of the off-gas streams from carbonator and calciner can be utilized to produce high temperature steam for electricity generation in a water steam cycle when combined with a conventional fossil fuel steam generation system. This is a key differentiator with respect to many first generation carbon capture processes, in which significant portions of energy are at temperature levels that allow no useful recovery but require degrading of energy by dumping into cooling systems.

To overcome the uncertainties of small scale tests as a basis for scale-up scenarios, the extensive long-term pilot testing under realistic operating conditions is required. Previous tests performed with a 1 MW<sub>th</sub> scale pilot plant at TU Darmstadt have confirmed the feasibility of the technology in short operation phases, while giving a solid ground to assess the required next steps of follow-up projects, aiming mainly at conversion improvement and reliability. Given the results obtained at TU Darmstadt and given that the next logical step of CCL technology industrialization is to move to larger demonstrations – in a scale of 10 MW<sub>th</sub> or more, the following key issues were identified at the project start:

- The process of CO<sub>2</sub> removal by carbonation and calcination is new and therefore the key process variables and control strategies must be determined for a wide range of operating conditions (e.g. using different fuels in the calciner) by operating an upgraded pilot plant.
- The CO<sub>2</sub> capture is strongly dependent on the reactor configuration, residence time of solids, and system thermal operation, and this dependence has to be modelled through process and 3D computational fluid dynamics (CFD) simulations for scale-up.

- More reliable experimental data, obtained from a wider set of measurements, taken on an upgraded version of the technology that is closer to realistic full operation conditions with different fuels, are necessary for the validation of models and assumptions on which the scale-up to larger units will be based.
- Economic evaluations, a thorough understanding of environmental effects and a methodical assessment of risks are required to give confidence for the scale-up of the technology.

### 1.2.1 Objectives

The major goal of the SCARLET project was to obtain reliable information and tools for the scale-up and pre-engineering of a 20 MW<sub>th</sub> CCL plant by continuous self-sustaining operation of an upgraded 1 MW<sub>th</sub> pilot plant at TU Darmstadt. The project should provide technical, economic and environmental assessments of this promising technology, as well as the fundamental expertise needed for the scale-up and integration of pre-commercialisation CCL facilities. By addressing these key challenges and demonstrating the upgraded technology at the TU Darmstadt pilot scale of 1 MW<sub>th</sub>, the project should give confidence for investments into a larger-scale unit, i.e. 20 MW<sub>th</sub>. After successful demonstration of units of this size, the technology will be ready for design and installation of commercial size units on utility boilers and other sources where CO<sub>2</sub> reduction is required. The following key objectives were addressed for the SCARLET project:

- Identification of the key process parameters and control strategies for the 1 MW<sub>th</sub> CCL pilot plant fuelled by hard coal and by lignite.
- Development of scale-up tools and guidelines for CCL reactor design and process layout, validated by experimental data of 1 MW<sub>th</sub> pilot plant)
- Design, cost estimation, and health, safety and technical risk assessment of a 20 MW<sub>th</sub> CCL pilot plant to be built at the Emile Huchet Site of Uniper France.
- Techno-economic analysis of CCL application to hard coal and lignite fired power plants as well as cement and steel industry at commercial full-scale.
- Environmental impact analysis of CCL application to hard coal and lignite fired power plants as well as cement and steel industry at commercial full-scale

### 1.2.2 Work plan

The work plan was divided up in 9 comprehensive work packages (see Figure 2). **WP1** focused on long-term tests in an upgraded 2 MW<sub>th</sub> pilot plant. Four comprehensive test campaigns of 4 weeks each for hard coal and lignite were conducted to investigate the long-term behavior of the process focused on sorbent stability and reactivity. In-furnace measurements (gas extraction probe for in-bed gas analysis, capacitive probe for measuring solid load and velocity) were carried out to further validate the developed models with these experimental data. Solid samples extracted while testing were analyzed to complete the set of data. Additionally, a modified solids flow measuring system was tested to create a reliable method for measuring solids mass flow at the high temperatures of the process.

For **WP2**, the main objectives were the development of steady-state and unsteady process models as well as CFD models for three different approaches. For the process model development the heat and mass balances of CCL plants were calculated. CFD model development was focused on the discrete element method (DEM), the two fluid model utilizing the energy-minimization multi-scale method (EMMS) and stochastic collision detection for particle/particle interaction. Experimental data were

used to validate the models by simulations performed for selected operating conditions. Additionally, concepts for improved design were elaborated with particular attention to the geometry.

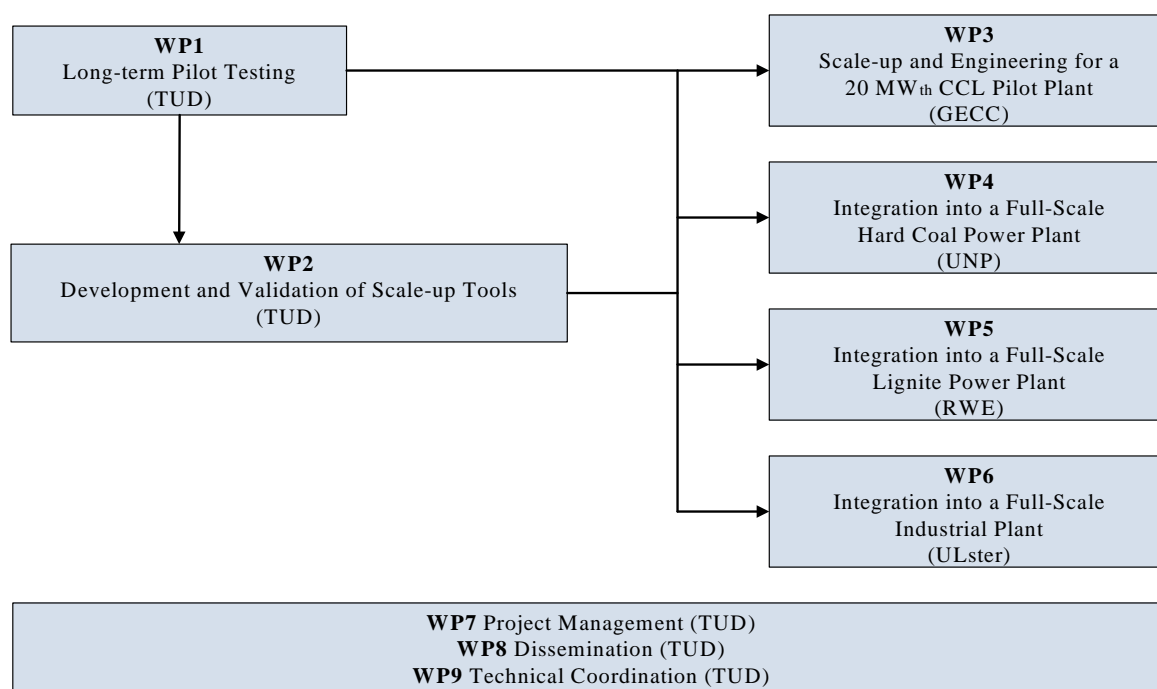

**Figure 2: Overall strategy of the work plan (WP leaders in brackets)**

**WP3** was focused on the design and engineering of a 20 MW<sub>th</sub> pilot plant utilizing the operational and design experience from the 1 MW<sub>th</sub> pilot plant tests (WP1), the design models and scale-up tools developed and validated (WP2). The workload comprised the definition of the process configuration, the design and engineering of reactor and auxiliary system, the definition of a measurement plan and operation procedures for various scenarios as well as detailed planning for operation and logistics. A health, safety and technical risk analysis was carried out for identification of potential risks and thereby supporting the initial permission actions. All information acquired were used to calculate the overall investment costs (CAPEX), operational costs (OPEX) and maintenance costs expected for the scaled-up 20 MW<sub>th</sub> pilot.

The objectives for **WPs 4-6** were the thermodynamic, economic and environmental evaluation for hard coal, lignite, steel and cement host plants. Therefore, existing plants were selected to provide the basis of design and the boundary conditions for the work to be carried out. The defined boundary conditions for the host plants were reconciled to guarantee the comparability of the results for the different plants considering the European Benchmarking Task Force definitions. This allowed the comparison of CCL with other capture technologies. Based on the host plant data, the thermodynamics (i.e. heat and mass balances, energy penalties) were calculated with the validated and scaled-up process model (WP2). With this input data, techno-economic analyses for the identification of cost of electricity (CoE) and cost of CO<sub>2</sub> avoided to evaluate CCL technology compared to other CCS solutions were carried out. In addition, the assessment of the environmental impact of CCL systems was conducted by a life cycle analysis (LCA).

All these tasks are accompanied by project management, dissemination and technical coordination activities in **WP7**, **WP8**, and **WP9**, respectively.

The SCARLET consortium consisting of 11 international members (see Table 1) including two universities, a research organization and 8 industrial partners with an excellent industrial support provided a strong platform to address the key challenges in scaling-up the CCL technology.

**Table 1: Details of the SCARLET consortium**

Full Name	Short Name	Country	Type
Technische Universität Darmstadt	TUD	DE	University
GE Carbon Capture GmbH	GECC	DE	Technology provider
Centre for Research & Technology Hellas	CERTH	EL	Research institute
University of Ulster	ULster	UK	University
Lhoist Recherche et Développement	LRD	BE	Material supplier
UNIPER Technologies	UNP	UK	Utility
RWE Power AG	RWE	DE	Utility
Steinmüller Babcock Environment GmbH	SBE	DE	Technology provider
ArcelorMittal Maizières Research SA	AM	FR	Steel producer
Cemex Research Group AG	CEMEX	CH	Cement producer
SWR Engineering Messtechnik GmbH	SWR	DE	Equipment provider

### 1.2.3 Innovative impact

SCARLET has brought CCL to the next level of maturity, preparing the ground for pre-commercial demonstration of the technology. By addressing the key challenges and demonstrating the technology at pilot scale of 1 MW<sub>th</sub>, the project gives confidence for investments into a larger-scale 20 MW<sub>th</sub> unit. With the help of validated simulation tools for scaling up the CCL process, scaling criteria were determined to facilitate the design of a future large-scale demonstration project, aiming at short term commercialisation of the process. Besides, the SCARLET project identified the technical and economic integration of CCL into a commercial power plant, a steel plant, or a cement plant to optimise performance and minimise technical risks, targeting efficiency, reliability, and operability. The innovative contributions are summarized as follows:

- The long-term operability and performance of the CCL process under realistic operation and conditions and a wide range of operating parameters in MW<sub>th</sub> scale was proven.
- Highly sophisticated simulation tools for process scale-up have been developed and validated with the experimental data of long-term pilot tests.
- Design and engineering of a 20 MW<sub>th</sub> pilot plant was carried out including operating procedures, health, safety and risk analyses showing no unmanageable risks as well as a calculation of investment and operational costs.
- Detailed thermodynamic, economic and environmental assessment of existing host power and industrial plants proofed the advantages in efficiency (low energy penalty), economics (low CO<sub>2</sub> avoidance costs) and environment (reduced environmental burden of host plants).

After successful demonstration of units of the 20 MW<sub>th</sub> size, the technology will be ready for design and installation of commercial size units on utility boilers and other sources where CO<sub>2</sub> reduction is required.



flue gases in bag filters. The inventory of solids in the carbonator and calciner is continuously determined by the measurement of the reactor pressure drop between the plane above the distributor and the exit of the reactor. The average composition of the solids entering and leaving the carbonator leaving is frequently determined from solid sampling using sampling ports in the loop seals and the screw conveyor. Also samples from the heat exchanger and the filters are taken.

### Long-term pilot testing

Four comprehensive long-term CaL test campaigns of four weeks each were conducted using hard coal either in pulverized and coarse form as well as pulverized or grained lignite, respectively. During these test campaigns, two different sorbents from western and southern Germany with different chemical compositions and particle size distributions were utilized. Semi-industrial pilot testing of the CCL process during 16 weeks with more than 1,200 hours of stable CO<sub>2</sub> capture showed the maturity of the process realizing high CO<sub>2</sub> capture rates in steady-state operation realizing operating points up to 60 hours. During steady-state operation, CO<sub>2</sub> absorption rates in the carbonator higher than 90 % and overall CO<sub>2</sub> capture rates higher than 95 % were proven under a wide range of parameters, e.g. fuel characteristics in the calciner, solid circulation rates, make-up rate etc.

A challenge of the CCL technology addressed in the pilot tests is the decreasing reactivity with increasing number of cycles of carbonation and calcination of the sorbent. Hence, a continuous feed of limestone as make-up is required in order to maintain a certain capacity of the sorbent to absorb CO<sub>2</sub>. Consequently, a realistic assessment of sorbent performance can only be provided by a homogeneous mixing of existing and continuous make-up feed. Therefore, extensive long term operating is required to achieve steady conditions of the sorbent phase. To investigate the sorbent performance, particular focus during operation was set on achieving steady state operating points, i.e. stable conditions of gas and sorbent phase. Thereby, the mean residence time of the sorbent was used to estimate the required period to achieve steady-state conditions in the solid phase. Three times the residence time of the sorbent, i.e. around 30-70 hours, ensure that at least 95 % of the inventory is exchanged by the make-up flow. Based on the screening, stable operating conditions based on the chemical composition of the sorbent samples were assessed. Extensive screening on selected solid samples has been performed based on chemical composition determined by X-ray fluorescence (XRF), the so-called loss

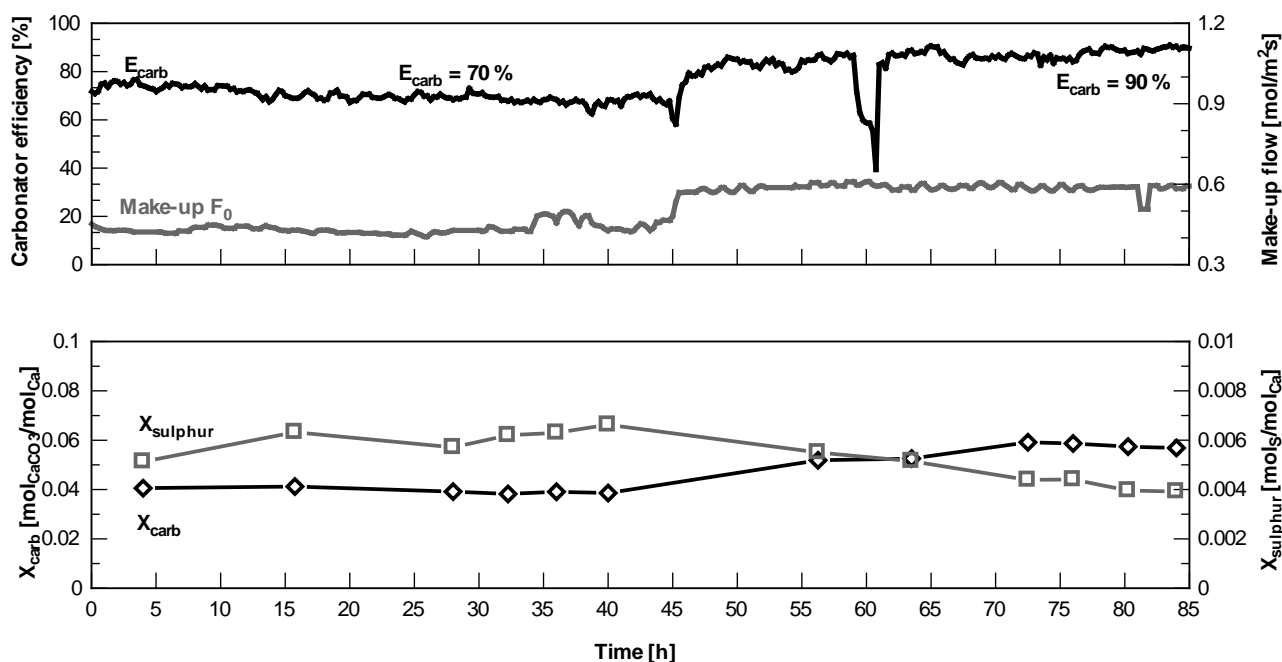

Figure 4: Exemplary steady-state operation from long-term pilot testing

on ignition (LoI) to quantify the amount of residual water, carbon and CO<sub>2</sub> as well as particle size distribution (PSD). More than 400 sorbent samples collected during the different test campaigns have been analyzed and steady-state operation points have been identified for evaluation.

An exemplary operation period of 85 hours is shown in Figure 4 when two steady-state operating points were achieved. The first steady state period was reached after 40 hours leading to the absorption efficiency in the carbonator of 70 %. In order to investigate the effect of an increased make-up rate, the make-up flow  $F_0$  was increased and the carbonator efficiency significantly rises until a new steady-state was reached absorbing 90 % in the carbonator. Solid analyses show a significant increase of the CO<sub>2</sub> carrying capacity ( $X_{\text{carb}}$ ) between both steady-state periods as well as the fraction of impurities, especially sulphated material ( $X_{\text{sulphur}}$ ) decreased. Consequently, more CO<sub>2</sub> can be absorbed at the same operating conditions.

Another focus of the investigation was the influence of the calciner fuel particle size and the fuel type on the composition of the sorbent circulation between the reactors and thus, the performance to absorb CO<sub>2</sub> from the flue gas lead in the carbonator since an increased amount of impurities represent an inactive fraction decreasing the ability of the sorbent of absorbing CO<sub>2</sub>. Figure 5 shows the effect of the fuel type and particle size on the sorbent circulating during CaL pilot tests with the same feed ratio of make-up. Obviously, significant difference in the amount of inactive material (gypsum, ash) can be observed both depending on the particle size and on the type of fuel. Using hard coal with the same composition and different particle size distribution, it can be observed that the share of gypsum is similar but ash differs. With coarse hard coal, more ash accumulates in the circulating solid stream compared to firing with pulverized coal (see Figure 5a). The particle size of the coal feed influences the ash separation efficiency in the calciner cyclone. The bigger the ash particles, the more ash is separated and accumulates in the circulating material. A significant difference in gypsum amount can be recognized comparing the composition of the samples for pulverized hard coal as well as lignite. A rather low of share gypsum accumulates in solid circulation firing lignite compared to hard coal. The low sulphur content of the lignite with 1.8 g<sub>sulphur</sub>/MJ compared to the hard coal with 5.6 g<sub>ash</sub>/MJ has a positive effect on accumulation of inert material in the process.

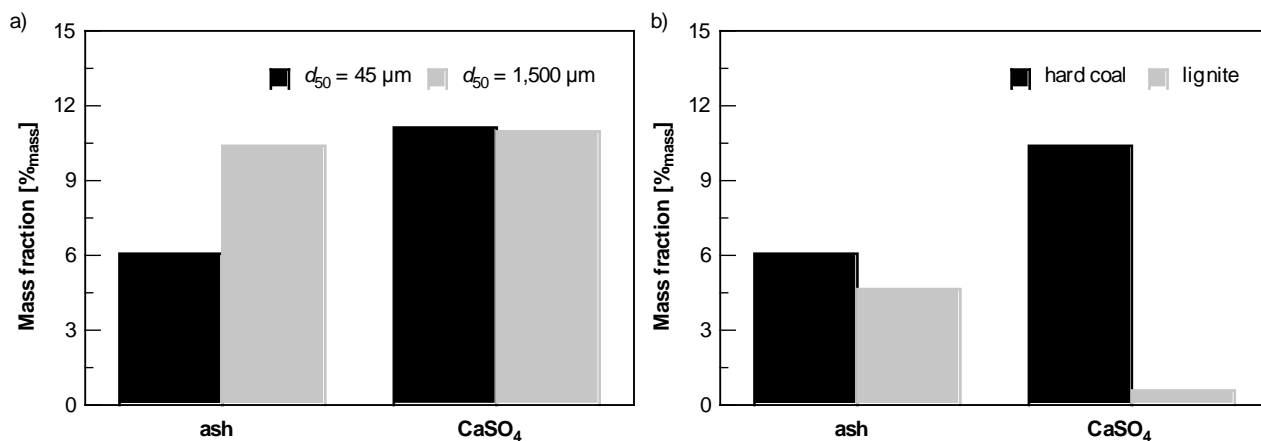

Figure 5: Solid composition of circulating sorbent with the same make-up rate using different fuel particle sizes (a) and different types of fuel with the same particle size (b) in the calciner

### In-furnace measurements

TUD constructed and installed two probes for in-furnace measurements of solids load and velocity as well as gas composition. A capacitance probe was used for particle flow pattern measurements, and a gas extraction probe combined with a mobile gas analysis system was used for gas composition



measurements. Detailed flow profiles could be recorded by horizontally traversing the probe and measuring at up to 30 positions along the reactor cross section.

An exemplary profile measurement of particle concentration and velocity profiles is shown in Figure 6. For all shown profiles, an increase of particle load towards the reactor wall is detectable in the entire reactor. There exists a clear core-annular flow structure with up-flowing particles in the reactor center and down-falling particles near the reactor wall. The results show the prevalence of a strong core-annular flow structure at almost every measured height inside the reactors. These results were very helpful for the validation of 3D CFD tools.

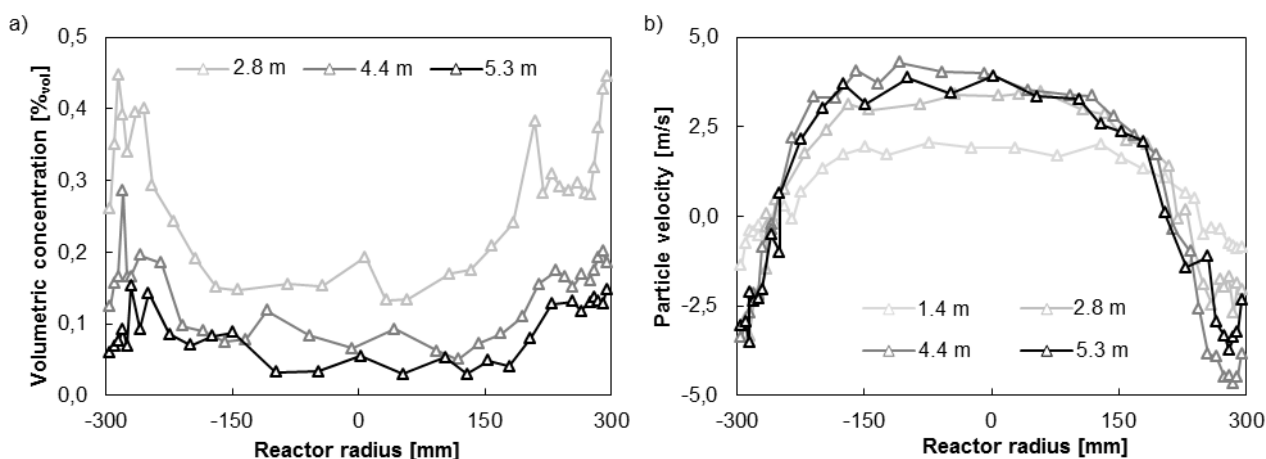

**Figure 6: Particle concentration profiles (a) and particle velocity profiles (b) at different heights in the carbonator**

### Main conclusions

Long-term pilot testing of the CCL process in 1 MW<sub>th</sub> scale was successfully conducted under a wide range of parameters under realistic operating conditions. The results show that high CO<sub>2</sub> absorption rates were achieved during steady-state operation, which will be the basis for validation of scale-up tools. Carbonator absorption rates of 80-90 % corresponding to total CO<sub>2</sub> capture efficiencies of 90-95 % were accomplished for periods up to 70 h in steady-state operation. Thus, the long-term pilot testing provides the experimental experience and data for reliable scale-up of the Calcium Carbonate Looping process. A broad data basis is provided for validating the developed scale-up tools in WP2, which were applied for a 20 MW<sub>th</sub> pilot plant in WP3. Crucial process parameters, e.g. make-up and sorbent looping ratio as well as fuel particle size in the calciner and temperatures in the reactors, strongly influence the engineering and could be identified. The gained experience of realistic long-time sorbent properties enables scale-up on a solid foundation the results were used to establish the design heat and mass balance of the scaled-up plant. The operating conditions favorable for high performance and interesting for further investigation in 20 MW<sub>th</sub> scale were based on the pilot experience. The experiences from the 1 MW<sub>th</sub> pilot plant in various fields, such as upgrade and reactor design (e.g. coal preparation and residence time in the calciner to avoid insufficient char burnout and transfer to carbonator), security reviews, measurement equipment, operating procedures etc. were transferred to WP3 as a basis for the measurement planning, the operating procedures as well as the health, safety and risk and the technical risk assessment.

### **WP2: Development and Validation of Scale-up Tools (TUD)**

A steady-state process model, a dynamic process model, and three-dimensional models for reactor simulation were developed and validated by experimental data from comprehensive test campaigns

in WP1. All models from WP2 were scaled-up to 20 MW<sub>th</sub> and applied to support the upscaling activities planned in WP3 to WP6.

### Steady-state process model

An existing in-house steady state process model [1] was advanced to account for the physical effects inside circulating fluidized bed reactors regarding the sorbent-gas and sorbent-sorbent interactions using the software ASPEN PLUS<sup>TM</sup> with customized FORTRAN routines. In the first place, the process model (Figure 7) is capable to predict mass and energy balances of the Calcium Carbonate Looping (CCL) system. Particles attrition effects and consequently overall reaction rates in both reactors were considered. The carbonator and the calciner are modelled by detailed circulating fluidized bed (CFB) sub-models (a, b in Figure 7). Each of the reactor sub-models take into account the CFB hydrodynamics, as well as reaction kinetics for carbonation and calcination [1, 2]. Both cyclones are modelled according to Muschelknautz [3], based on the dimension of those cyclones applied in the pilot plant. Figure 8 depicts the simulated efficiencies of carbonator ( $E_{\text{Carb}}$ ) and calciner ( $E_{\text{Calc}}$ ) that are in good accordance with experimental data obtained during four different operating points in tests from WP1.

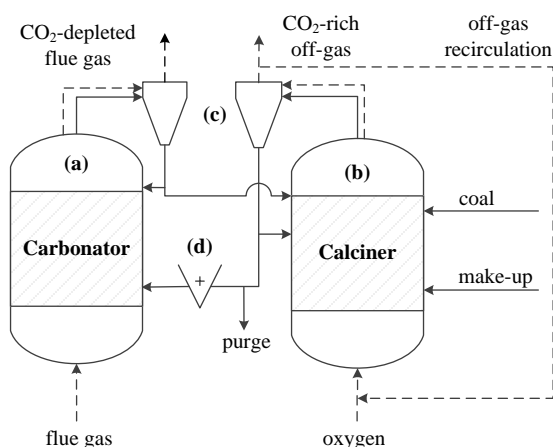

**Figure 7: Simplified flowsheet of the steady-state process model**

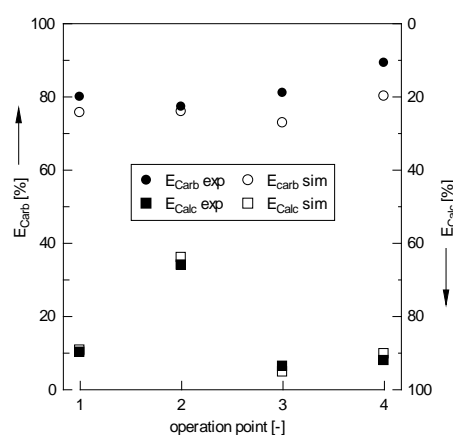

**Figure 8: Comparison of carbonator and calciner efficiencies**

### Dynamic process model

A dynamic process model was developed using the software ASPEN PLUS Dynamics/Custom modeler. The model includes a detailed reactor model for the carbonator that includes several sub-models to calculate among other values e.g. the entrainment rate, hydrodynamics, particle distribution and CO<sub>2</sub> absorption rate depending on the history of limestone. Furthermore, the model calculates a heat and mass balance of the carbonator in association with custom-built sub models that consider hydrodynamics and heat transfer among phases (Figure 9). Hence the model allows the prediction of the reactor temperature over time as it is exemplary depicted in Figure 10 during start-up operation. The detailed thermodynamic model allows the calculation of the reactor temperature for different operating conditions. Hence realistic start-up, shut-down and load change scenarios using burner power or pre-heated air can be investigated and studied with the model. The sorbent distribution is described by a two-zone model according Kunii and Levenspiel that assumes perfect sorbent mixing in each zone. Additionally, a sub-model for considering the effects of steam on the CO<sub>2</sub> absorption rate was included. Appropriate loop controllers can be used to set up specified behavior of single CCL plant components (e.g. screw-conveyer, electrical pre-heaters etc.). The dynamic process model was vali-

dated with experimental data during start-up, shut-down and load change showing satisfactory agreement during all operating phases of the CCL plant. After thorough model validation with experimental data from 1 MW<sub>th</sub> pilot plant the model was scaled-up to 20 MW<sub>th</sub>, see WP3.

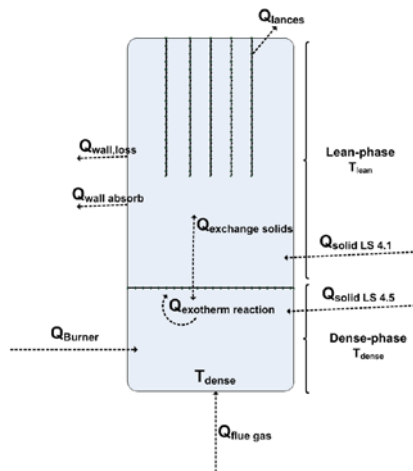

Figure 9: Thermodynamic heat streams of dynamic carbonator process model

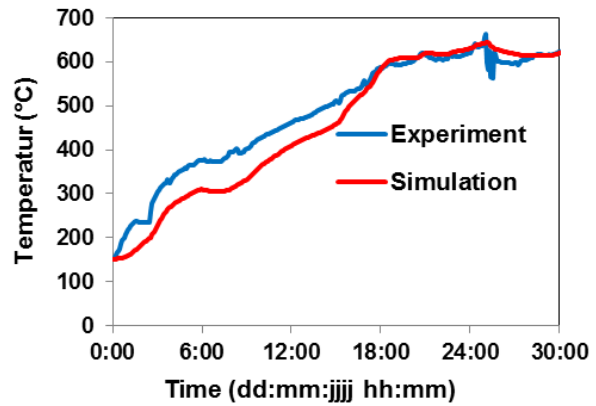

Figure 10: Simulated carbonator temperature profile during start-up operation

### 3D CFD models

3-D Computational Fluid Dynamics (CFD) tools were developed and validated for the simulation of the gas-solid flows inside the carbonator and calciner reactors. The models were developed using three different numerical approaches that can be divided in Euler-Lagrange and Euler-Euler (Figure 11). In the latter mentioned method, the particulate phase is treated as a fluid with closure equations according the theory of granular flows to describe the solid properties. In the former case the particles are tracked in the course of time with individual properties such as diameter, velocities, densities, sorbent conversion etc. Furthermore, the Euler-Lagrange models can be distinguished by their collision methodology, either deterministic or stochastic based collision formulation. The coarse grain discrete element method model that is based on a deterministic collision algorithm was developed by TUD while the stochastic based collision models were developed by GE. The Euler-Euler

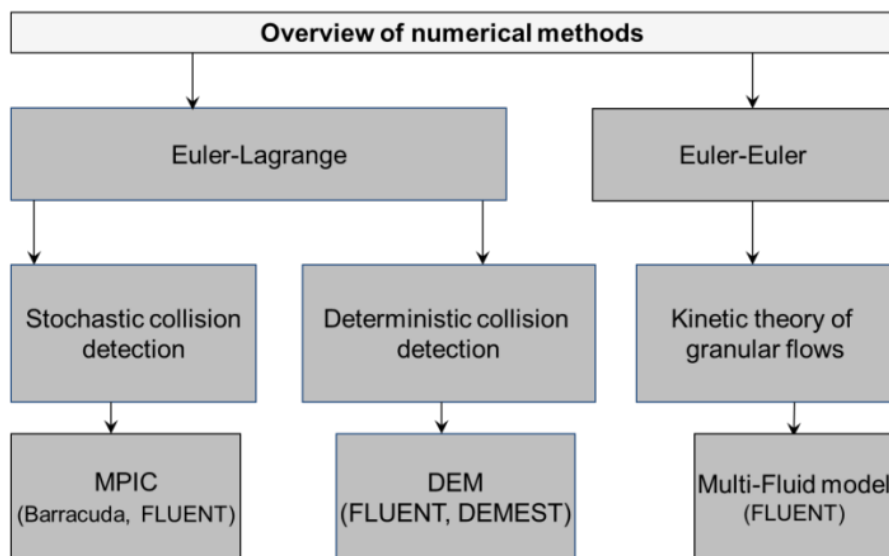

Figure 11: Numerical methods applied in Task 2.3

model was incorporated by CETH/CPERI. In all models appropriate reaction rates were applied either retrieved from the recent literature or small scale experimental batch reactor tests. Apart from this, a new version of the innovative sub-grid EMMS (Energy Minimization Multi-Scale) method was applied to the Euler-Euler and Euler-Lagrange models for considering a realistic description of momentum exchange between phases. Due to that, the particle distribution in the CFB unit was simulated more realistically in comparison to conventional drag models. Additionally, a routine was implemented to maintain a realistic particle size distribution for inert ash and reactive limestone particles during the transient simulation. For modeling of the appropriate drag, reaction rates and particle size distribution were integrated by means of custom built models in the C programming language into the ANSYS platform using User Defined Functions (UDFs).

The developed Barracuda approach based reactor models couple first principle thermochemical models (particle physical properties, particle chemistry, and gas-particle reaction kinetics) with scalable hydrodynamic models, to provide a robust basis for describing performance at various scales. The modelling of reactors considers mass and heat transfer between gas and particle species, multiple simultaneous reactions, and heat loss to the environment. Reactor modelling also considers the entire circulation loop, capturing particle entrainment flux and allowing the tracking of individual particles, both position and associated properties in time. Figure 12 depicts on the left hand side two instantaneous contour plots of the solids distribution using Gidaspow and EMMS drag models. It can be seen that the EMMS model gives a more pronounced dense zone with a thinner lean zone in comparison to the conventional Gidaspow model. Additionally the pressure profile is directly affected by the particle distribution, as it is depicted on the right hand side of Figure 12.

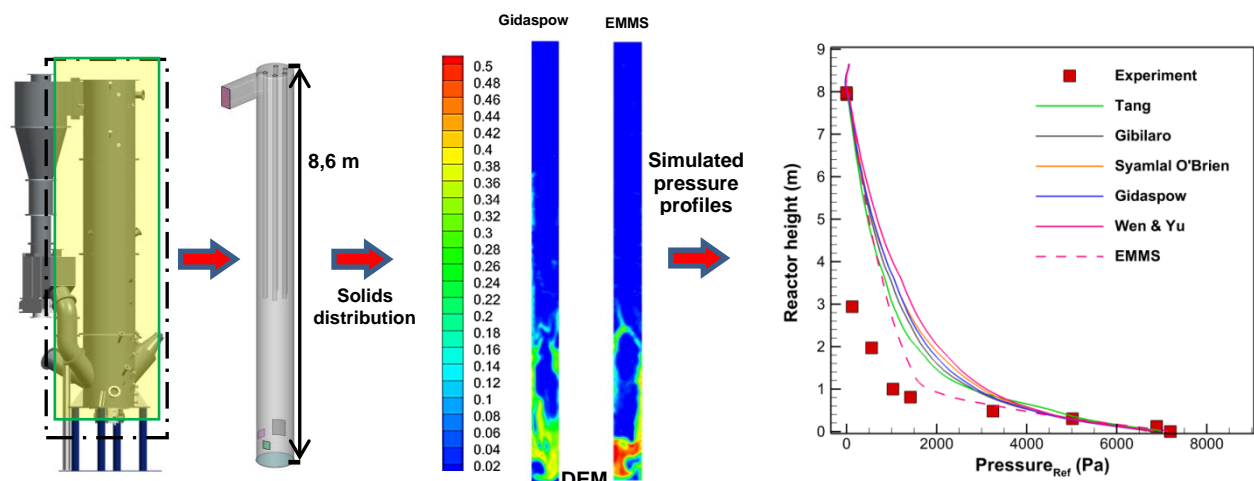

Figure 12: CFD modeling results of 1 MW<sub>th</sub> scale

### Design improvements

Potential design improvements were investigated on the experiences from 1 MW<sub>th</sub> pilot testing, validated process and 3D models respectively. The experiences from pilot testing allow identifying optimization potentials, especially in geometry of the carbonator calciner, cyclones, loops seals and devices for coupling between the two fluidized bed reactors for different operating conditions. Furthermore, the CFD analysis in terms of CO<sub>2</sub> absorption efficiency favored a modified carbonator fat bottom design, that yielded a higher capture efficiency than the original design. Design improvements were jointly defined in a separate workshop. TUD integrated the proposed design modifications for the 1 MW<sub>th</sub> plant into an existing scaled cold flow model and tested the performance under cold conditions (Figure 13). Experiments consisted of four separate configurations: each fluidized bed (CFB600=carbonator, CFB400=calciner) internally recirculating on its own, known as *stand-alone operation*, and two configurations in which solids circulation occurred between fluidized beds,

known as *coupled operation*. By adjustment of the J-valve and cone valve, it was possible to control the amount of solids between reactors and achieve stable operation. The removal of LS4.5 from the reactor configuration was also investigated. In this case, the cone valve's transfer capacity improved so much that the J-valve became the limiter of solids transfer between the two reactors. However, the configuration was much more vulnerable to gas bypass, especially at start-up, because fluidization air from CFB 600 could flow directly up the standpipe into the cyclone of CFB 400.

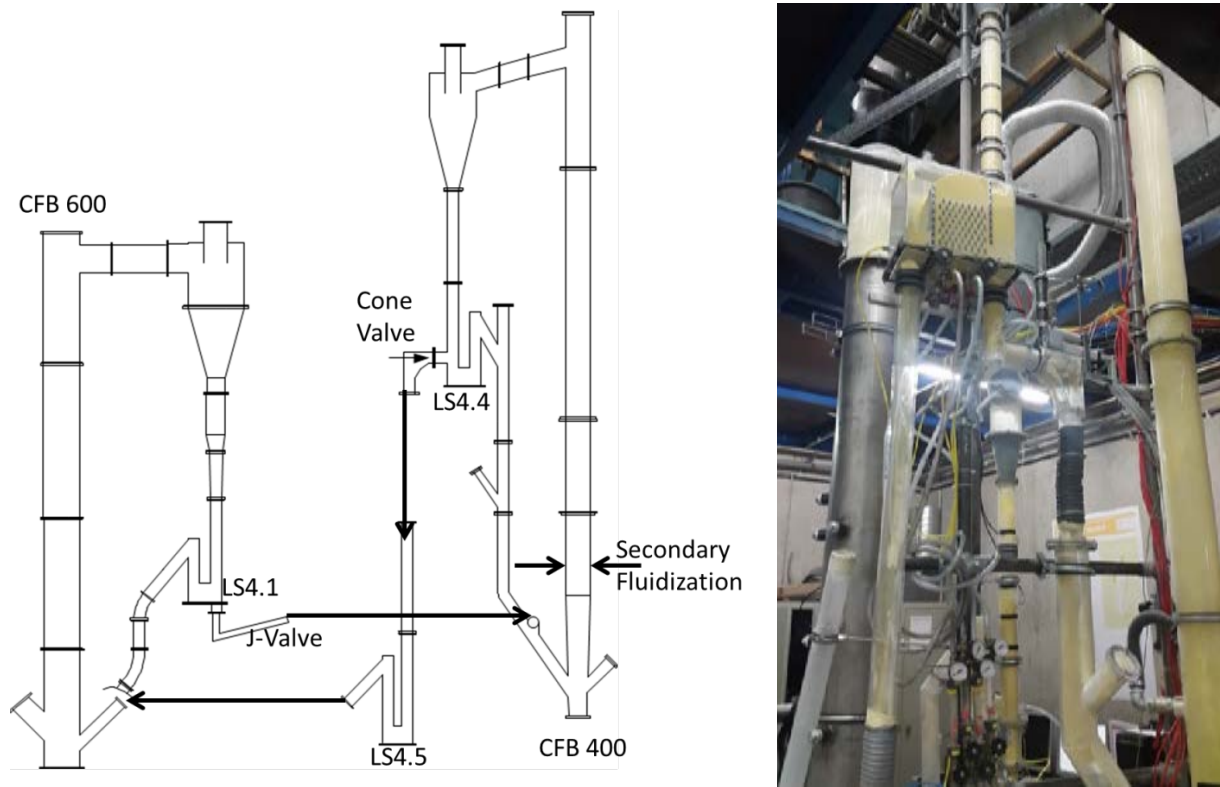

Figure 13: Scheme of Cold Flow Model (left) and adaption with FBHE loop seal (right)

### Conclusions

The developed models in WP2 are strong tools that can be used for the process scale-up. The developed steady-state process model successfully validated by the experimental data in 1 MW<sub>th</sub> scale allows to define the design heat and mass balance in 20 MW<sub>th</sub> scale in WP3 and to assess the full-scale implementation in WPs4-6. The developed 3D CDF models allow to evaluate the design based on the process modelling. Detailed investigations of reactor geometries and its effect on the performance are possible.

### **WP3: Scale-up and Engineering for a 20 MW<sub>th</sub> CCL Pilot Plant (GECC)**

The main objective of WP3 was to develop a conceptual design for a 20 MW<sub>th</sub> pilot plant that demonstrates the next step for the development and scale-up of the CCL technology towards industrial implementation. The process configuration and nominal operation conditions with mass & heat balances for the 20 MW<sub>th</sub> pilot plant were established based on the results of WP1 & 2 utilizing validated scale-up tools. The components of the 20 MW<sub>th</sub> pilot plant were designed and engineered, comprising the fluidized bed reactors with their auxiliaries, the coal, sorbent make-up and oxygen supply systems, the spent sorbent/ash handling system, the heat recovery to the water/steam cycle, the flue gas filtration, the CO<sub>2</sub> purification system as well as all utility systems required. A detailed measurement plan was defined and the operation was studied including normal operation, start-up &

shut-down procedures and the logistics for the supply of consumables and the disposal of residuals. Piping & instrumentation diagrams and the plant layout arrangement were elaborated depicting all major components of the pilot plant. A Health and Safety Risk Assessment and a Technical Risk Assessment were carried out for identification of potential risks and subsequently the process to obtain the required permission from the authorities for the erection and operation of the 20 MW<sub>th</sub> pilot plant was evaluated. All information acquired was used to calculate the overall investment cost, operational costs and maintenance costs for the scaled-up 20 MW<sub>th</sub> pilot plant. Unit 6 of the Emile Huchet power plant was selected as the theoretical host site for the integration of the 20 MW<sub>th</sub> pilot plant. The selected 600 MW<sub>e</sub> coal-fired power station, owned and operated by Uniper, is located in Saint-Avold in France.

### Process Definition

A Basis of Design (BoD) was defined comprising main boundary conditions selected for the design of the 20 MW<sub>th</sub> pilot plant. Table 2 gives an overview of main boundary conditions selected for the design of the 20 MW<sub>th</sub> pilot plant.

**Table 2: Boundary conditions of 20 MW<sub>th</sub> pilot plant design**

Parameter	Value
Coal for host plant & calciner	Hard coals (“El Cerrejon” & “US high sulfur”)
Coal particle size for calciner	$d_{50} < 90 \mu\text{m}$
CO <sub>2</sub> in flue gas to carbonator @ 100 – 52 % EH6 capacity	10.2 – 7.2 mol-% wet
CO <sub>2</sub> capture efficiency	approx. 90 %
CO <sub>2</sub> product quality	> 95 mol-% (saline aquifer quality)
Thermal duty total (calciner/carbonator)	20 (12.2/7.8) MW <sub>th</sub>
Sorbent	Lhoist “Limestone 0.1-0.3mm Messinghausen”
O <sub>2</sub> purity	99.5 mol-%
O <sub>2</sub> /moderation gas mix	40 – 50 mol-% O <sub>2</sub>
Emission limits	per Industrial Emissions Directive (IED)

### Process Configuration and Process Description

The process configuration for the 20 MW<sub>th</sub> pilot plant was defined (see simplified scheme in Figure 14) utilizing the experience from the 1 MW<sub>th</sub> pilot plant tests (WP1), the validated models and scale-up tools developed (WP2) and the expertise of the involved partners in power and chemical plant engineering in general, as well as specifically in scale-up of new CCS technologies.

A slip stream of flue gas is taken from the existing flue gas duct downstream of the wet flue gas desulfurization (Wet FGD) of Unit 6 and is routed to the carbonator via a fan and a gas preheater. In the Carbonator the flue gas is contacted with CaO in a circulating fluidized bed, and the CO<sub>2</sub> contained in the flue gas will react with solid CaO to CaCO<sub>3</sub>. A first cyclone separates the solids from the treated CO<sub>2</sub> lean flue gas stream, which is sent back via a heat recovery system and a particulate filter to the flue gas duct of the host power plant. Loaded sorbent is transferred via a loop seal with cone valve for flow control to the calciner. In the calciner CaCO<sub>3</sub> will be calcined in a fluidized circulating bed by means of coal combustion under moderated oxy combustion conditions. A first cy-

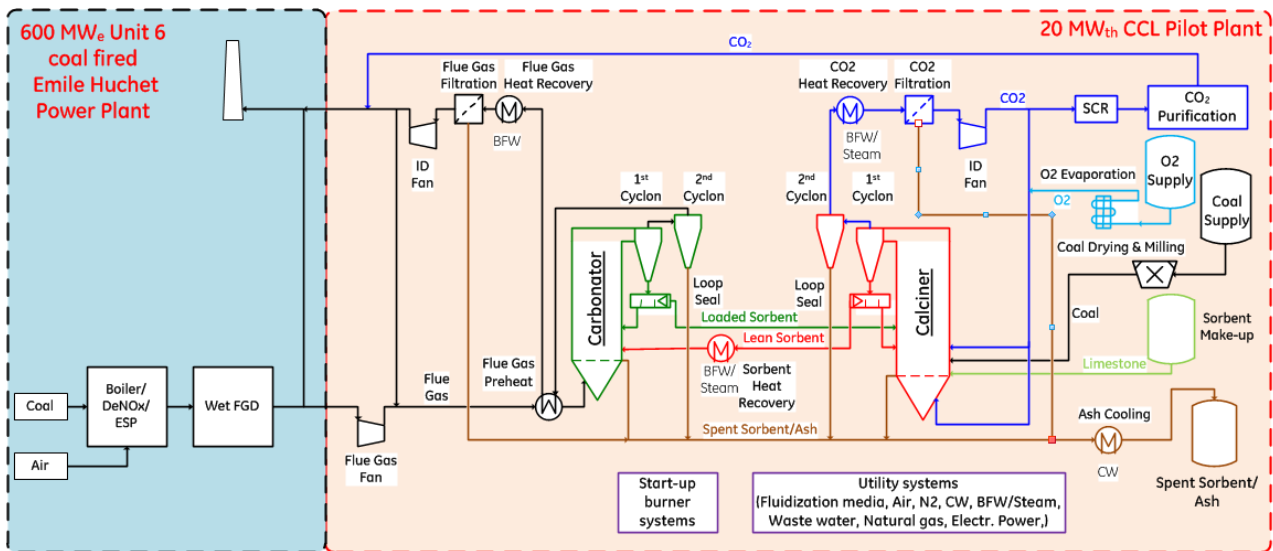

**Figure 14: Simplified Process Flow scheme**

clone separates the regenerated sorbent from the CO<sub>2</sub> rich flue gas. The calcined sorbent is returned for repeated CO<sub>2</sub> capture to the carbonator via a loop seal with cone valve for flow control and a sorbent heat recovery system, which generates steam by solid cooling. A second cyclone limits solid entrainment to the downstream filters under normal operation and during plant upsets.

The CO<sub>2</sub> rich flue gas is routed to a CO<sub>2</sub> purification unit via a heat recovery system, particulate filter and a Selective Catalytic Reactor (SCR) reducing the NO<sub>x</sub> emissions. Within the CO<sub>2</sub> purification unit the CO<sub>2</sub> is enriched to >95 mol.-% CO<sub>2</sub> purity. A small portion of the CO<sub>2</sub> is dried and utilized for fluidization and inertization purposes. Since there is no further use of the remaining CO<sub>2</sub> stream foreseen in this pilot project, the CO<sub>2</sub> product is mixed with the treated flue gas stream from the Carbonator and routed via the flue gas duct and stack of the host plant to atmosphere.

Heat recovered from CO<sub>2</sub> lean flue gas, CO<sub>2</sub> rich flue gas and from the Sorbent Heat Recovery system is utilized to produce steam from boiler feed water (BFW) supplied from the host plant. The steam produced is used either inside the pilot plant, for coal drying or as fluidization medium, or exported to the infrastructure of the existing power plant. Coal is supplied from the host power plant coal yard. Before the coal is sent to the calciner it is dried and milled to the targeted particle size. Limestone sorbent for make-up is supplied from trucks to a hopper. From the hopper, sorbent is pneumatically transported to a feeder system and finally discharged to the calciner. Oxygen is supplied from tanks as this seems the most cost effective solution for pilot purposes. The oxygen is stored as a liquefied gas and evaporated before being fed to the process. Spent sorbent and ash separated by filters and cyclones are cooled and temporarily stored before being disposed

### Nominal operating conditions

The nominal operation points for the 20 MW<sub>th</sub> pilot plant were defined and chosen in order to investigate crucial process parameters, as identified during pilot testing in WP1. With the CCL process model for the 20 MW<sub>th</sub> pilot plant, derived from the validated model developed in WP2, mass & heat balances for each of the selected eleven (11) operation points were created. The varied process parameters include for example carbonator temperature, calciner temperature, sorbent make-up flow, sorbent circulation flow, flue gas composition & flow to carbonator, oxygen concentration to calciner, Carbonator inventory, etc. Table 3 below shows main parameters resulting from the generated mass & heat balances for the design and engineering of the reactors and auxiliary systems.



**Table 3: Main process parameters**

Parameter	Value
Flue gas flow to carbonator	10.0 – 17.5 t/h
Coal flow to calciner	1.0 – 1.8 t/h
Make-up sorbent flow	1.9 – 3.0 t/h
Sorbent circulation flow	22.7 – 48.9 t/h
Oxygen flow to calciner	2.0 – 3.8 t/h
Carbonator temperature	650 - 675 °C
Calciner temperature	900 - 950 °C
Carbonator inventory	1 – 1.5 t/m <sup>2</sup>

### Design and engineering of reactors and components

Based on the process definition and the developed mass & heat balances, the design of the reactor systems and auxiliary components was conducted. The core components of the 20 MW<sub>th</sub> pilot plant are the two coupled circulating fluidized bed (CFB) reactors. Different 3D CFD simulation models, developed within WP2, were used to predict and confirm reactor system performance and to optimize the geometry and operating conditions of the reactor components (see also WP2 description for more details). Based on the CFD models and operational experience, a superficial gas velocity of 5 m/s was selected for both carbonator and calciner reactors to achieve the targeted fast fluidized bed flow regime ensuring sufficient fluidization above the minimum fluidization velocity of the particles involved. This velocity resulted in a required cross-sectional area of both reactors of approximately 2.25 m<sup>2</sup> (square area of 1.5 m × 1.5 m). A height of 20 m was selected to achieve the required residence time of the particles for the carbonation reaction in the carbonator, as well as the calcination reaction and coal burnout in the calciner. Further, the height of both reactors is driven by layout requirements to provide the required height that will ensure both the gravitationally driven flow of solids through cyclones and loop seals back to the reactors and the adequate slope of piping to accommodate the angle of repose for the solids involved. Both reactors were designed to be made from refractory-lined carbon steel with a square cross-sectional area. Based on the 3D CFD model results it was concluded that the actual design is promising to reach the specified CO<sub>2</sub> capture rate of 80 % for the Carbonator and of 90 % for the complete pilot plant. Besides the reactor systems, all auxiliary systems required to operate the pilot plant were designed, including the flue gas connections to the host power plant, the coal handling system, the sorbent make-up system, the oxygen supply system, the spent sorbent/ash handling system, the CO<sub>2</sub> purification system, the heat recovery and filter systems as well as utility systems required. The 20 MW<sub>th</sub> pilot plant requires to be equipped with extensive measurement devices due to its pilot character to evaluate the CCL process for R&D purposes and for extending the validation of related tools to a larger scale. A detailed measurement plan with approximately 500 measurement services was elaborated focusing on process evaluation in the scaled-up pilot plant.

### Operating Procedures

Normal operation, start-up and planned/emergency shut-down procedures, including control concepts, were defined based on the results from engineering and the experience from pilot testing in WP1. The work was supported by dynamic process simulation studying the dynamic behaviour of



the 20 MW<sub>th</sub> pilot plant during start-up and shut-down and other major transient scenarios identified. The simulation tool was based on a validated 1 MW<sub>th</sub> dynamic process model.

### Planning of logistics

Using available data on the amount and characteristics of consumables, utilities required and wastes produced, the logistics of the pilot plant were determined. Additional traffic for supply of consumables and for removal of wastes was evaluated as well as the availability of utilities from the host power plant. It was concluded that the traffic will increase by 8 to 14 vehicles per day depending on the pilot plant operation mode. Suitable tie-in points for provision of utilities from the host power plant-

### Piping & Instrumentation Diagrams (P&IDs)

Based on the previous design and engineering work - like process configuration, equipment design, measurement plan and operating procedures - Piping & Instrumentation Diagrams (P&IDs) were prepared. The P&IDs form a set of drawings which depict the process scheme, type and material of process equipment, required process instrumentation, including analytical equipment and control loops, as well as required sizes and materials for major piping/ducts.

### Layout planning

A plant layout plan and 3D CAD software model of the 20 MW<sub>th</sub> pilot plant was created to design and engineer the required arrangement of the different subsystems, equipment, and interconnecting piping of the pilot plant. It provides an overview of the dimensions and general arrangement of the 20 MW<sub>th</sub> CCL pilot plant integrated into the Emile Huchet power plant. It further supported cost estimate, permitting evaluations and risk assessments done in WP3. Uniper, the power plant owner, selected an appropriate plot area for the 20 MW<sub>th</sub> pilot plant close to the tie-in points to Unit 6. With the information about the plot area as well as process and equipment design requirements, a 3D CAD software model was developed with focus on the assembly of the carbonator and calciner reactor systems (CFB reactors, cyclones, loop seals and fluidized bed heat exchanger) as well as the arrangement of the solid circulation coupling between these two systems. Figure 15 shows a 3D model view and the developed layout plan of the 20 MW<sub>th</sub> pilot plant.

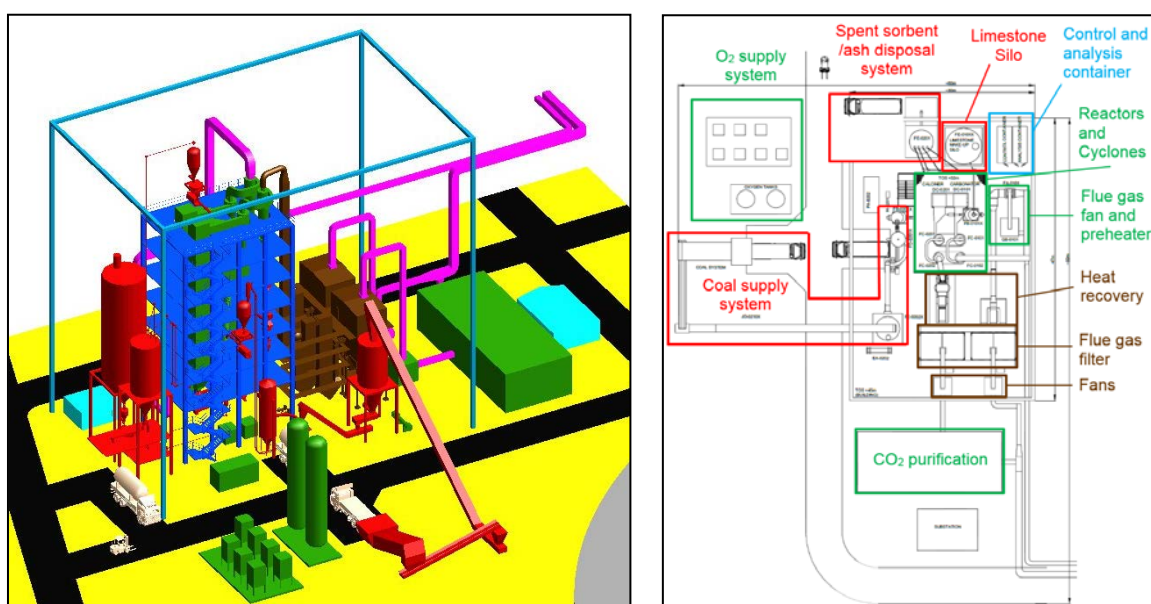

Figure 15: 3D model view (left) and layout plan (right) of the 20 MW<sub>th</sub> pilot plant

### Risk assessments

A Health and Safety Risk Assessment was carried out to identify potential health & safety risks by conducting a Process Hazard analysis with Hazard Study 1 methodology (HAZID). It was identified that some hazardous potential is associated, for example, with an inadvertent release of different process media like flue gas, natural gas or lime, which could cause harm to operators through the threat of asphyxia or irritations or cause an environmental pollution. Another risk is the handling of combustible media like coal or natural gas, which could potentially cause a fire or explosion. As a result, a risk mitigation plan was developed. Further, a Technical Risk Assessment was conducted to identify the potential technical risks by a Failure Mode & Effect Analysis (FMEA) considering experience from the erection and operation of the 1 MW<sub>th</sub> plant.

Generally, being a pilot plant the risk profile for the 20 MW<sub>th</sub> pilot plant is higher than for a commercial unit as expected since certain technology validation steps have not been executed yet. However, risks can be minimized by mitigation actions and no risks associated with the pilot plant have been identified that would be considered unmanageable. The risk assessments shall be reviewed, particularized and updated in subsequent project implementation phases.

### Determination of costs

All information acquired was used to estimate the overall investment costs as well as operating and maintenance costs expected for the scaled-up 20 MW<sub>th</sub> pilot plant. The Capital Cost (CAPEX) was calculated using the “Total Installed Cost” (TIC) reflecting an accuracy of -25% / +30 %, based on actual cost (1<sup>st</sup> quarter 2017) having western European cost basis. Operating cost (OPEX) was calculated based on a five-year plant operation with an annual operating time of 2.000 hours for testing purpose. The maintenance cost was included in the OPEX and is based on experienced percentage per year based on CAPEX cost.

The CAPEX cost of the pilot plant considers the following:

- Equipment & bulk material (piping, electrical, instrumentation, spare parts, etc).
- Labour and subcontracts (construction, bulk installation, civil works, structural steel, buildings, insulation, painting, etc)
- Services (engineering, project management, procurement, temporary facilities, construction management & supervision, commissioning and start-up)
- Plant Integration (connections to battery limit, permitting, etc.)

The OPEX cost of the pilot plant considers the following:

- Personnel cost for operational and testing staff
- Cost for consumables (feedstocks, chemicals, utilities, waste disposal)
- Maintenance cost

Contingencies for CAPEX (20%) and OPEX (10%) are recommended to reach a high probability of underrun the cost. Table 4 gives an overview of CAPEX and OPEX cost estimated.

The cost data shown are to be considered specific for the pilot plant where relatively high costs are associated with high degree of instrumentation, high plant flexibility, high utility costs, local sourcing and R&D personnel cost. Thus, cost data shown should not be used for prorating to commercial units. Furthermore, economy of scale and value engineering efforts may result in lower cost for commercial CCL technology like further process optimization, reduction of margins for equipment design and less instrumentation, optimization of utility cost, international sourcing, etc.

**Table 4: Estimated total cost for the 20 MW<sub>th</sub> pilot plant incl. 5 years of operation**

	Base cost	Total Cost including contingency (without risk & profit)
CAPEX	53.0 million €	63.6 million €
OPEX	13.2 million €	14.5 million €
Total	66.2 million €	78.1 million €

### Permitting Activities

On completion of the preliminary permitting activities, it has been concluded that there are no unsurmountable issues to obtain the permit to operate the planned 20 MW<sub>th</sub> pilot plant.

### Conclusion

The results of the pilot plant engineering activities give confidence to interested parties for investments into a larger-scale 20 MW<sub>th</sub> unit from a technical perspective. The results of WP3 do not reveal any significant or unsurmountable obstacles with regards to design, engineering, operational, logistical, safety or permitting aspects. Thus, the WP3 team is confident that the CCL technology could be erected and operated in a 20 MW<sub>th</sub> pilot to test and evaluate the characteristics of this technology at the next bigger scale in order to gain further knowledge and experience, eliminate potential problems, achieve required learnings and to enhance the technology.

CCL technology is a promising 2<sup>nd</sup> generation carbon capture technology, but must be evaluated and tested at larger scale before commercialization. CCL technology is very interesting for incorporation into smaller industrial applications (cement, steel), waste incineration plants or biomass power stations which would normally require a scale-up of the planned pilot plant by a factor of 3 to 5 only compared to the 20 MW<sub>th</sub> pilot scale. Existing infrastructure and other process equipment may be used, thus minimizing the expenditures for the total installation. This means commercialization could be realized in a reasonable time frame based on the knowledge gained on the operation of the 20 MW<sub>th</sub> pilot plant.

### **WP4: Integration of CCL into a Full-scale Hard Coal Power Plant (UNP)**

This work package studied the integration of the CCL technology into a full-scale coal-fired power plant. The existing Emile Huchet Unit 6 power plant, located in Saint-Avold in France, was selected to conduct the study. Owned and operated by Uniper, this is a 600 MW<sub>e</sub> coal-fired power station fitted with flue gas desulphurisation (FGD) and selective catalytic reduction (SCR) for reduction of SO<sub>x</sub> and NO<sub>x</sub> respectively.

Although the Emile Huchet power plant burns a variety of world-traded bituminous coals with varying sulphur content, for the purpose of this study it has been assumed that the plant combusts a single coal. The Emile Huchet power plant cases selected in the study are listed in Table 5. These represent the design (100 %), the minimum (52 %) and two intermediate loads. The load refers to the amount of fuel entering the burners divided by the amount of fuel required for the design value. A combustion calculation with the selected coal was conducted in order to make the study comparable with the assessment of other CO<sub>2</sub>-capture technologies. The composition and mass flow of the flue gas streams were calculated based on the power plant characteristics, mainly the excess air during combustion, the amount of leakage air, as well as the operation conditions of the FGD unit. Considering the conditions of the four different load cases, the composition of the flue gas streams was determined. Part-load operation of the host plant leads to considerable lower CO<sub>2</sub> concentration in the flue gas. As the main consequence, the conditions for CO<sub>2</sub> absorption in the carbonator worsen.

**Table 5: Load Cases and flue gas properties from power plant**

Load	%	100	81.0	66.3	52.0
Fuel input	t/h	213.07	172.58	141.30	110.88
Thermal input	MW <sub>th</sub>	1505.12	1238.31	1008.19	752.29
Gross power	MW <sub>e</sub>	623.1	510.0	407.5	303.6
Auxiliary power	MW <sub>e</sub>	35.2	30.2	26.6	23.5
Net power	MW <sub>e</sub>	587.9	479.8	380.9	280.1
Net efficiency	%	39.13	38.78	37.84	36.94
CO <sub>2</sub>	vol.%	10.18	9.54	8.33	7.21
H <sub>2</sub> O	vol.%	11.40	11.40	11.40	11.40
SO <sub>2</sub>	ppmv	55.69	52.18	45.54	39.41
O <sub>2</sub>	vol.%	6.67	7.42	8.84	10.16
N <sub>2</sub>	vol.%	71.75	71.64	71.43	71.23
Mass flow	kg/s	901	777	725	654

A simplified process scheme of the calcium carbonate looping process with the secondary water-steam cycle is shown in Figure 16. Within the calcium carbonate looping process, two hot gas streams at a high temperature level are used for steam generation: the CO<sub>2</sub>-depleted flue gas from the carbonator at 650 °C and the CO<sub>2</sub>-rich stream from the calciner at 900 °C. The heat that needs to be extracted from the carbonator is supplied to the secondary power cycle as the third heat source.

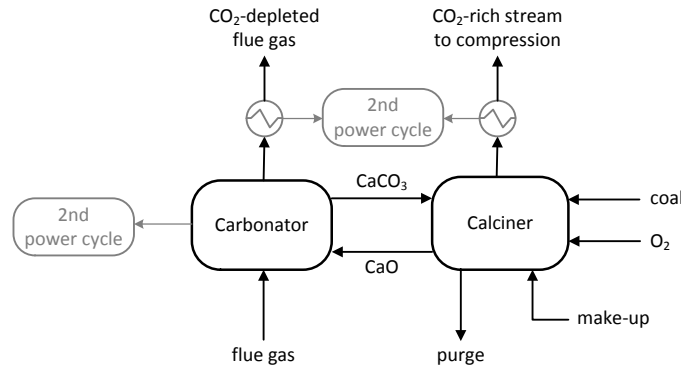

**Figure 16: Simplified integration of CCL Process with secondary water steam cycle**

To evaluate the efficiency penalties in comparison to the reference process without CO<sub>2</sub> capture, an electric efficiency according to Eq. (1) was calculated. In this equation,  $\eta_{ref}$  expresses the reference electric efficiency of the whole unit without CO<sub>2</sub> capture,  $\eta_{EH6}$  the electric efficiency of the power plant and  $\eta_{sec,CCL}$  the electric efficiency of the secondary water steam cycle attached to the CCL system. The last two efficiencies were weighted by the corresponding share of the thermal duty,  $Q_{EH6}$  and  $Q_{CCL}$ .

$$\eta_{ref} = \frac{Q_{EH6}}{Q_{EH6} + Q_{CCL}} \times \eta_{EH6} + \frac{Q_{CCL}}{Q_{EH6} + Q_{CCL}} \times \eta_{sec,CCL} \quad (1)$$

Based on the flue gas composition and mass flow, the CO<sub>2</sub> absorption rate and subsequently the performance of the CCL whole system were calculated. The main results are shown in Figure 17. This figure depicts the overall net electric efficiency and the efficiency penalties related to the weighted reference efficiency calculated using Eq. (1). The net efficiency penalty for the full-load case was approximately 3.5 percentage points without CO<sub>2</sub> compression and 7.0 percentage points including the CO<sub>2</sub> compression system. During minimum load operation, these numbers increase

to 4.9 / 8.6 percentage points which is mainly due to the reduced CO<sub>2</sub> concentration in the flue gas from the power plant.

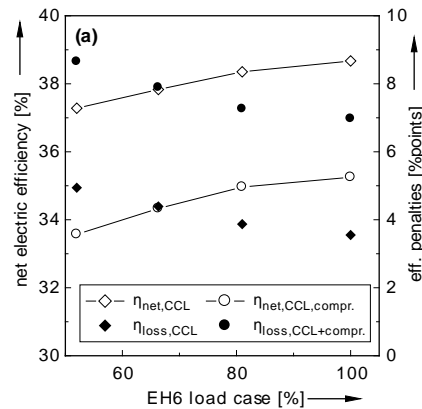

Figure 17: Net Electric Efficiency and Efficiency Penalty at Different Power Plant Loads

This study also estimated the capital investment and the operational and maintenance costs for the CCL unit in order to calculate levelised cost of electricity (LCOE) and CO<sub>2</sub> avoidance cost using ECLIPSE software. The CCL technology has also been compared with other CO<sub>2</sub> capture solutions.

The most significant component of the direct cost for integration of a calcium looping process with a hard coal power plant for CO<sub>2</sub> capture is the CCL capital cost. A bottom-up approach was used to estimate the overall unit cost for this study. To get the basic information about the system with CO<sub>2</sub> capture, mass and energy balances (including utility calculations) were generated. A detailed cost model for the CCL plant including main equipment, design and installation was developed for the CCL CO<sub>2</sub> capture integration. A breakdown of the capital cost is shown in Figure 18. For the selected 600 MW power plant, the CCL plant capital cost was estimated to be about €669 million, giving an additional specific investment of €724/kW<sub>e</sub>.

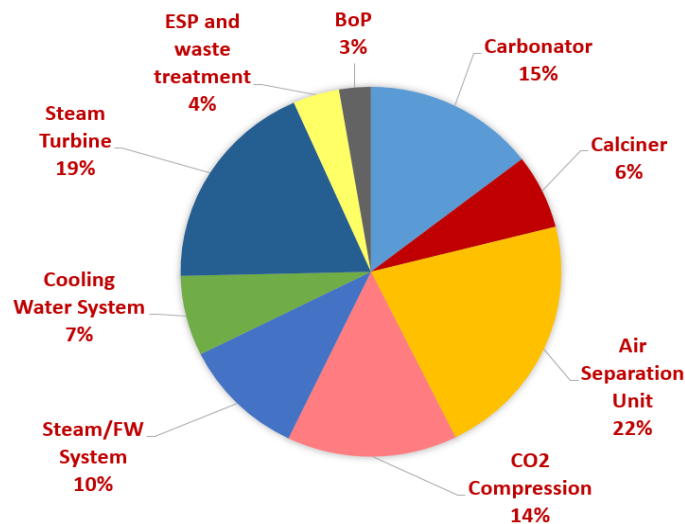

Figure 18: Breakdown of the Capital Costs for the Calcium Looping Process

In this study, the amount of CO<sub>2</sub> avoided was 771.9 g/kWh. The CO<sub>2</sub> capture cost and CO<sub>2</sub> avoidance cost relative to the corresponding reference plant were €15.4/t CO<sub>2</sub> captured and €20.2/t CO<sub>2</sub> avoided, respectively.

A comparison between CCS technologies was performed. The results showed that using the CCL technology in hard coal power plants for CO<sub>2</sub> capture instead of MEA post-combustion or oxyfuel

combustion technologies gave an improvement in the capture efficiency and the cost of CO<sub>2</sub> avoidance.

A life cycle analysis (LCA) was completed to evaluate the environmental impact of CCL technology integrated with the coal-fired power plant. The study made a comparison between the hard coal power plant with and without CCL. The environmental impacts of the plant technology and its potential hazards to human, wildlife, and bio-systems were considered. The LCA was carried out using the ReCiPe methodology, and both the midpoint and endpoint were considered. SimaPro 8.3 was used to model the system. The study assumed that the 600 MW power plant was operating at full load. The study was a cradle-to-gate type, and capital goods were not included. The electricity retained 100 % of the environmental burden. This was because the CCL is a cleaning system. Its resultant product, CO<sub>2</sub>, has no value. The endpoint damage assessment results are shown in Figure 19.

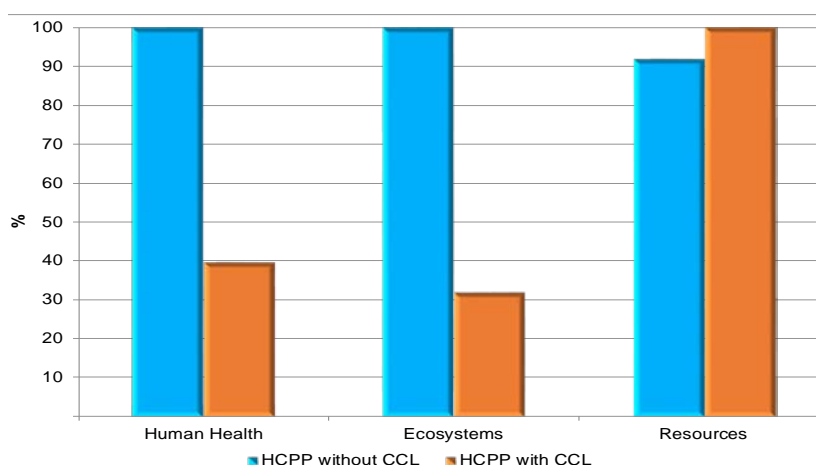

**Figure 19: Endpoint Damage Assessment Results**

The endpoint analysis indicates that generating electricity has a lower environmental impact with the employment of CCL as a decarbonisation tool than without CCL. The damage assessment results indicate a 60 % and 68 % reduction in potential impact for the human health and ecosystems indicators respectively. This is achieved via a 9 % increase in the resource indicator.

The midpoint analysis indicates that some impact categories are lowered by the integration of CCL and others are raised. This is to be expected as the CCL plant consumes resources to function. An increased use of resource will have an environmental impact. However, this has to be balanced against a 72 % reduction in the climate change impact category. Impact categories that were reduced by the retrofit of the CCL technology are those that are normally affected by the flue gas emissions: climate change, terrestrial acidification, particulate matter formation and natural land transformation.

Overall, the results indicate that the power plant with CCL has a lower environmental burden than the base hard coal power plant. The increased resource use can be justified by the reduction in the climate change impact.

This study could be expanded by including any potential CO<sub>2</sub> credit resulting from the spent sorbent landfill capture, as well as any potential reduction from the cement plant calciner displacement. To complete the cradle-to-gate analysis, the construction phase of the systems should also be considered.

### Conclusion

The evaluation of economics and thermodynamics and the comparison to other CCS technologies show the advantages of CCL. The efficiency penalty and the CO<sub>2</sub> avoidance costs are significantly lower compared to other technologies, i.e. amine scrubbing or oxy-fuel (see Figure 20).

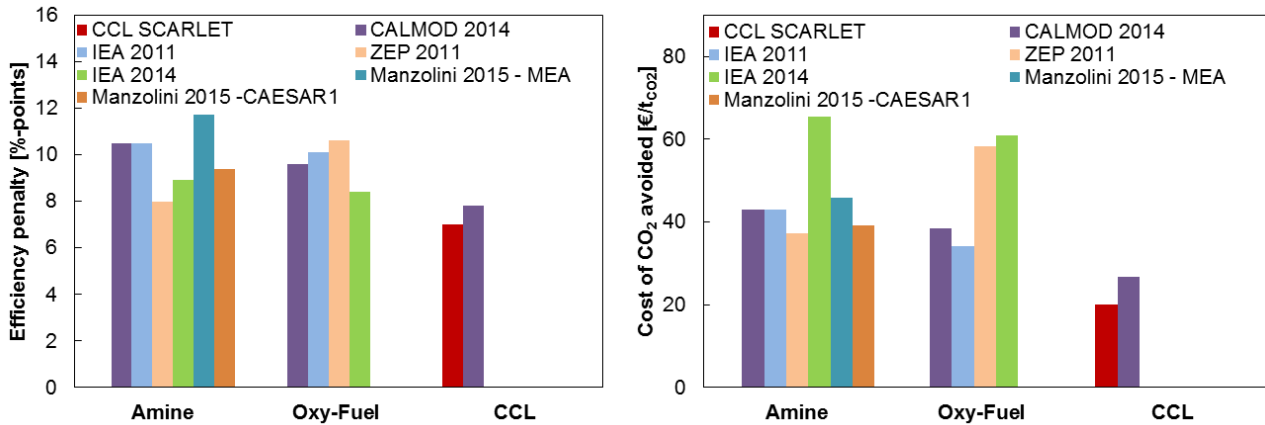

Figure 20: Comparison of efficiency penalty and CO<sub>2</sub> avoidance costs for hard coal power plants

### WP5: Integration of CCL into a Full-scale Lignite Power Plant (RWE)

This work package studied the integration of the CCL technology into a full-scale lignite-fired power plant. The existing BoA1 power plant, located in Niederaußem in Germany, was selected to conduct the study. Owned and operated by RWE, this is a 944 MW<sub>e</sub> lignite-fired power station equipped with once through supercritical steam generators with single reheat and all necessary flue gas cleaning equipment for dust (electrostatic precipitator) and SO<sub>x</sub> (wet limestone FGD).

The BoA1 power plant burns a variety of Rhenish lignite from various local opencast pits. For the purpose of this work package, it has been assumed that the plant combusts a single coal for the power plant and the same pre-dried lignite in the CCL process. The properties of the coal are shown in Table 6. It has been assumed that this fuel will be used by both the power plant and the CO<sub>2</sub> capture plant.

Table 6: Coal Properties

		<i>as received</i>	<i>pre-dried</i>
Moisture	%	54.5	12
Ash	%	4.9	9.5
Carbon	%	27.3	52.8
Hydrogen	%	2	3.9
Nitrogen	%	0.4	0.8
Oxygen	%	10.3	19.9
Sulphur	%	0.6	1.1
Gross calorific value	MJ/kg	10.8	
Net calorific value	MJ/kg	9.01	19.7
CO <sub>2</sub> emission	g/kWh LHV	400	

The BoA power plant cases selected in the study are listed in Table 7. These represent the design (100 %) and the minimum (48 %) loads. The load refers to the amount of fuel entering the burners divided by the amount of fuel required for the design value. A combustion calculation with the selected coal was conducted in order to make the study comparable with the assessment of other CO<sub>2</sub>-capture technologies. The composition and mass flow of the flue gas streams were calculated based on the power plant characteristics, mainly the excess air during combustion, the amount of leakage air, as well as the operation conditions of the FGD unit. Considering the conditions of the four different load cases, the composition of the flue gas streams was determined. Part-load operation of the

host plant leads to considerable lower CO<sub>2</sub> concentration in the flue gas. As the main consequence, the conditions for CO<sub>2</sub> absorption in the carbonator worsen.

**Table 7: Load cases and flue gas properties from lignite power plant**

parameter	unit	load case	
		100%	48%
thermal input	MW <sub>th</sub>	2195	1047
gross power output	MW <sub>e</sub>	989	439
auxiliary power consumption	MW <sub>e</sub>	45	31
net power output	MW <sub>e</sub>	944	408
electric efficiency (net)	%	43	39
electric efficiency (gross)	%	45	42
CO <sub>2</sub>	vol.%	12.52	11.35
H <sub>2</sub> O	vol.%	16.16	16.16
SO <sub>2</sub>	vol.%	0.01	0.01
O <sub>2</sub>	vol.%	4.19	5.45
N <sub>2</sub>	vol.%	67.12	67.04
mass flow	kg/s	1118	589

A simplified process scheme of the calcium carbonate looping process with the secondary water-steam cycle is shown in Figure 16, as already shown in WP4.

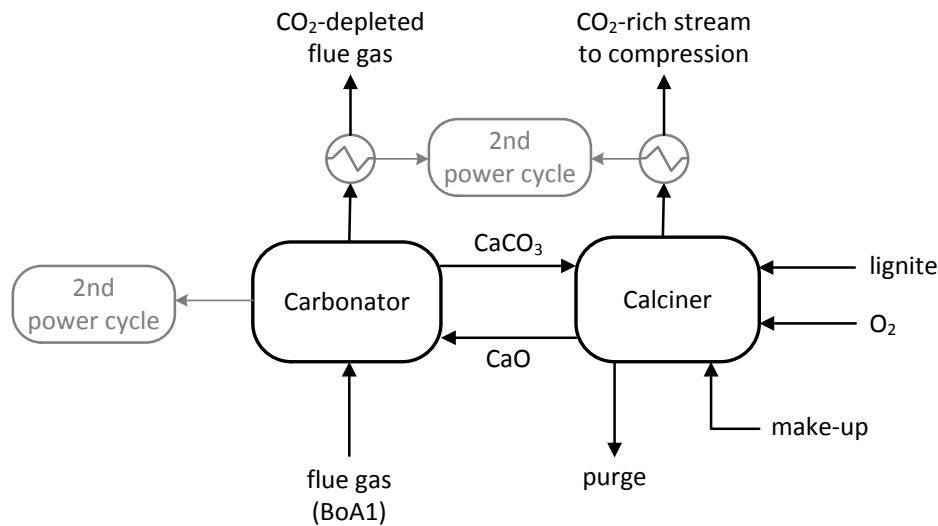

**Figure 21: Simplified Integration of CCL Process with Secondary Water Steam Cycle**

To evaluate the efficiency penalties in comparison to the reference process without CO<sub>2</sub> capture, an electric efficiency according to Eq. (1). was calculated. Based on the flue gas composition and mass flow, the CO<sub>2</sub> absorption rate and subsequently the performance of the CCL whole system were calculated. The main results are shown in Figure 17. This figure depicts the net electric efficiency  $\eta_{net,CCL}$  and  $\eta_{net,CCL+compr.}$  as well as the arising net electric efficiency penalties  $\Delta\eta_{loss,CCL}$  and  $\Delta\eta_{loss,CCL+compr.}$  for the system without and with the CO<sub>2</sub> compression. The net electric efficiency of the BoA1 unit at full load operation without CO<sub>2</sub> capture is marked with the dotted red line. In the base case (pre-dried lignite) the net electric efficiency of the power system is 40.08 %, and 36.59 % considering the electrical demand of the CO<sub>2</sub> compression unit. The efficiency penalties increase from 2.93 / 6.42 %points (pre-dried) to 3.59 / 7.37 %points (as received) for the system without and with the CO<sub>2</sub> compression system, respectively, which is mainly due to the reduced CO<sub>2</sub> concentration in the flue gas from the power plant.



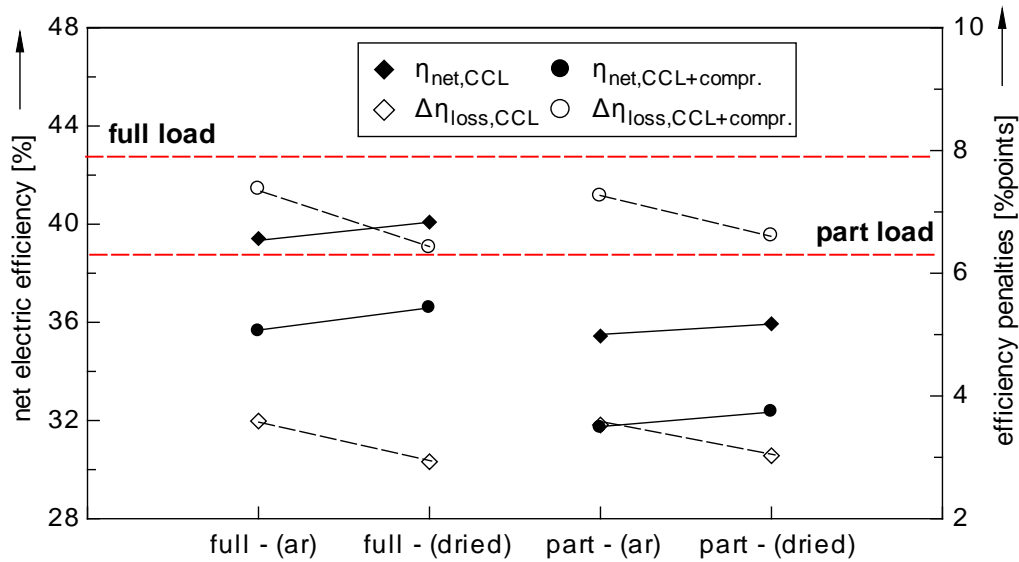
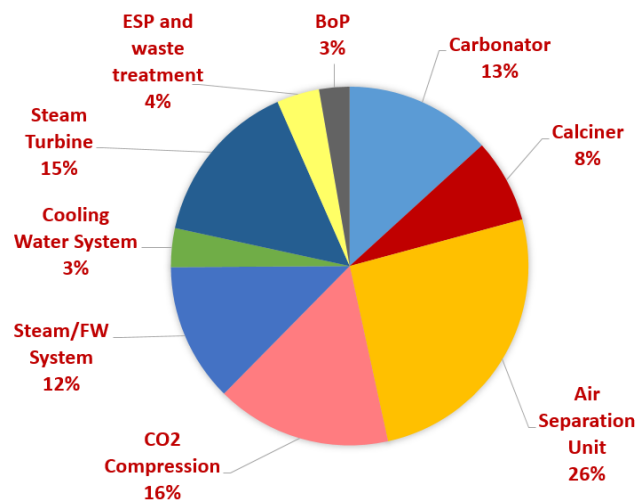

**Figure 22: Net electric efficiency and efficiency penalties for full and part load operation as well as varying moisture content of the lignite**

This study also estimated the capital investment and the operational and maintenance costs for the CCL unit in order to calculate levelised cost of electricity (LCOE) and CO<sub>2</sub> avoidance cost using ECLIPSE software. The CCL technology has also been compared with other CO<sub>2</sub> capture solutions.

According to the cost estimation approach in WP4, a breakdown of the capital cost is shown in Figure 18. For the selected 1000 MW lignite power plant, the CCL plant capital cost was estimated to be about €1022 million, giving an additional specific investment of €466/kW<sub>e</sub>.

In this study, the amount of CO<sub>2</sub> avoided was 685.7 g/kWh. The CO<sub>2</sub> capture cost and CO<sub>2</sub> avoidance cost relative to the corresponding reference plant were €19.8/t CO<sub>2</sub> captured and €26.9/t CO<sub>2</sub> avoided, respectively.



**Figure 23: Breakdown of the Capital Costs for the Calcium Looping Process**

A life cycle analysis (LCA) was completed to evaluate the environmental impact of CCL technology integrated with the coal-fired power plant. The study made a comparison between the lignite power plant with and without CCL, according to the methodology presented in WP4. The endpoint damage assessment results are shown in Figure 24.

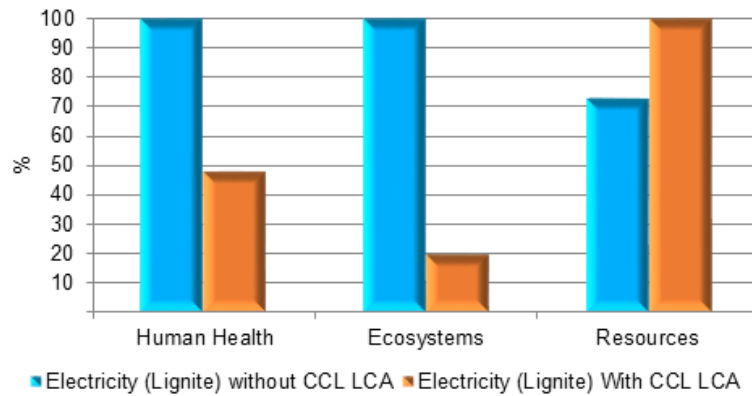

**Figure 24: Endpoint Damage Assessment Results**

The endpoint analysis indicates that generating electricity has a lower environmental impact with the employment of CCL as a decarbonisation tool than without CCL. The damage assessment results indicate a 52% and 80% reduction in potential impact for the human health and ecosystems indicators respectively. This is achieved via a 27% increase in the resource indicator.

The midpoint analysis indicates that some impact categories are lowered by the integration of CCL and others are raised. This is to be expected as the CCL plant consumes resources to function. An increase use of resource will have an environmental impact. However, this has to be balanced against an 82% reduction in the climate change impact category. Impact categories that were reduced by the retrofit of the CCL technology are those that are normally effected by the flue gas emissions; climate change, terrestrial acidification, particulate matter formation and natural land transformation.

Overall, the results indicate that the power plant with CCL has a lower environmental burden than the base lignite power plant. The increase resource use be justified by the reduction in the climate change impact.

This study could be expanded by including any potential CO<sub>2</sub> credit resulting from the spent sorbent landfill capture, as well as any potential reduction from the cement plant calciner displacement. To complete the cradle to gate analysis the construction phase of the systems should also be considered.

Conclusion

The evaluation of economics and thermodynamics and the comparison to other CCS technologies show the advantages of CCL. The efficiency penalty and the CO<sub>2</sub> avoidance costs are significantly lower compared to other technologies, i.e. amine scrubbing or oxy-fuel (see Figure 25).

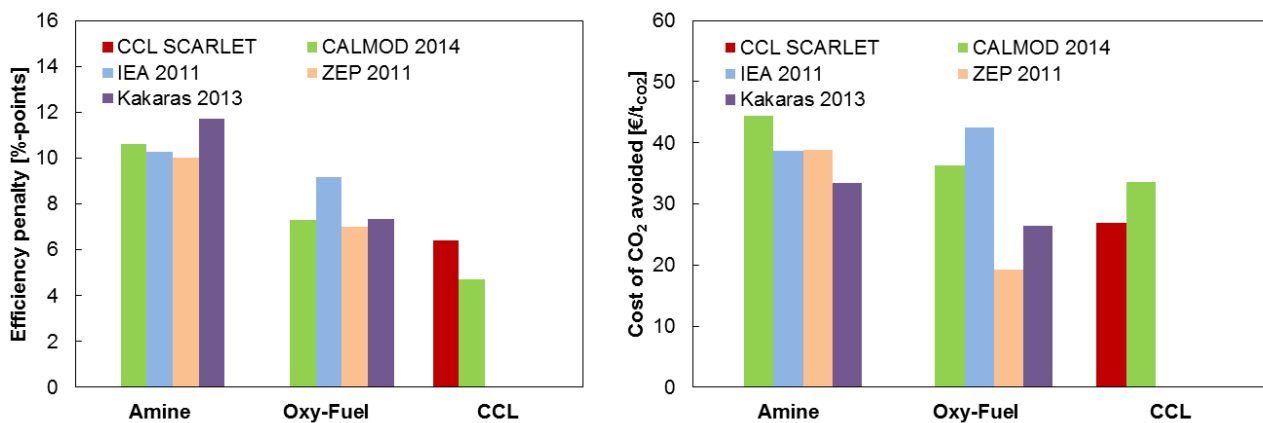

**Figure 25: Comparison of efficiency penalty and CO<sub>2</sub> avoidance costs for lignite power plants**

## WP6: Integration of CCL into Full-scale Industrial Plants (ULster)

Following the experience acquired in the EU projects, the published results of the ULCOS project (Ultra-Low Carbon dioxide Steelmaking) and the Technology Roadmap for carbon capture and storage in industrial applications, published by the International Energy Agency and the United Nations Industrial Development Organization, the research group selected existing cement and steel production plants to be equipped with a CCL plant. In this package the CCL models validated in WP2 were used to define the processes of full scale cement and steel plants. Main objectives of WP6 are:

1. Evaluation of the process regarding full-scale implementation to cement steel plants;
2. Techno-economic analysis, identification of cement production cost and cost of CO<sub>2</sub> avoided to evaluate CCL technology compared to other CCS solutions;
3. Assess the environmental impact of CCL system by conducting a life cycle analysis (LCA).

### Cement plant definition and integration

In this task an existing cement plant was selected to be equipped with a CCL unit in order to provide the basis of design and the boundary conditions for thermodynamic and economic evaluations to be done in the scope of SCARLET project. The European Benchmarking Task Force definitions are taken into account to guarantee comparability of the results between WPs 4, 5 and 6 as well as comparability with other capture technologies. The selected cement plant is able to produce over t/day clinker. In order to show the influence of the extraction point of the flue gases, two integration cases, as shown in Figure 26 and Figure 27, are configured.

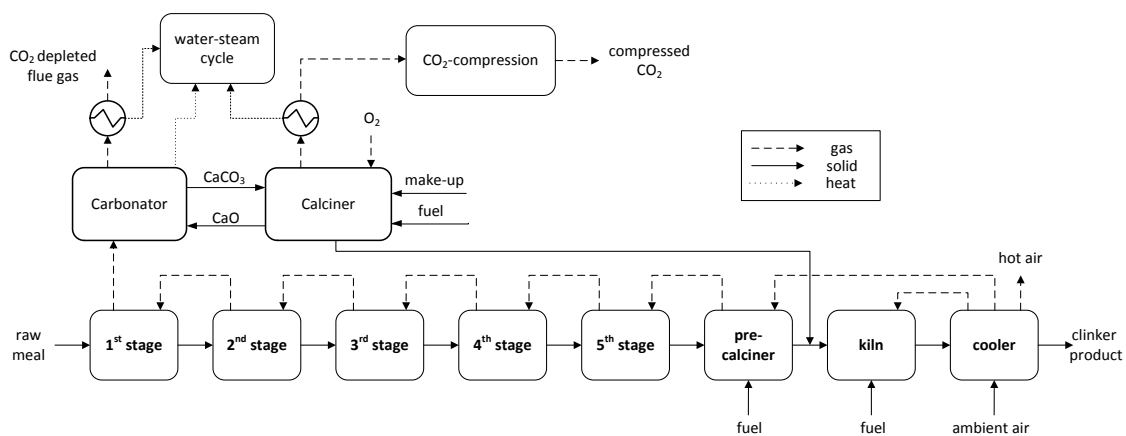

**Figure 26: Simplified schematic of the CCL integration case**

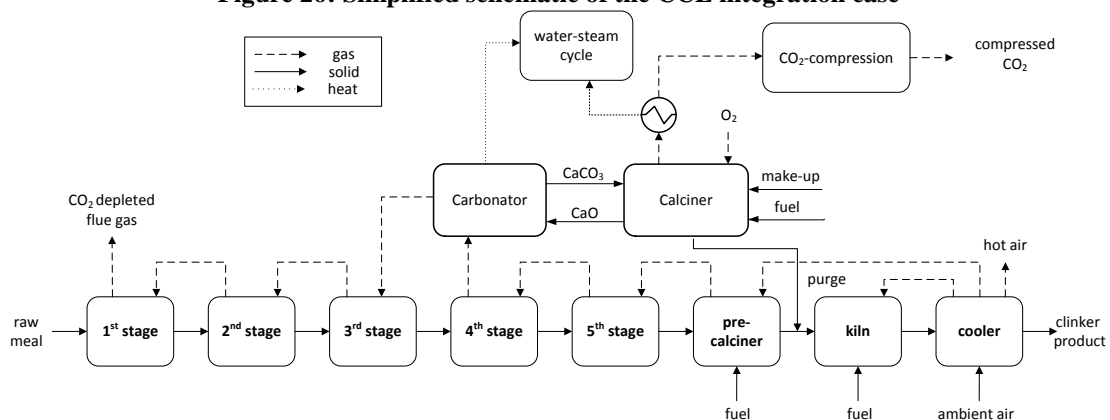

**Figure 27: Simplified schematic of the CCL integration case II**

### Integrated steel mill definition and integration

Based on the information provided by our industrial partners and gathered through literature reviews, an integrated steel mill (ISM) is selected. The selected ISM is able to produce 457t/hr of Hot Rolled Coil (HRC). The assessment of the decarbonisation of ISM is rather challenging due to the high complexity of all processes that are interconnected. Taking all factors into account, four major processes for the ISM are selected for an integration of a CCL into the ISM in this study. A simplified process diagram is shown in Figure 28.

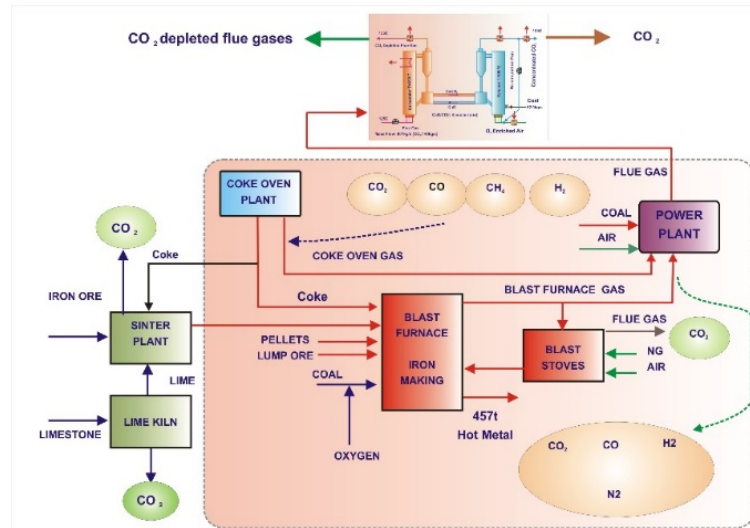

**Figure 28 : Simplified iron and steel plant integrated with a CCL plant**

### Thermodynamic evaluation of CCL for the selected cement plant

The  $\text{CO}_2$  absorption efficiency of the carbonator,  $E_{\text{Carb}}$  and the total  $\text{CO}_2$  capture rate of the whole system,  $E_{\text{tot}}$ , are presented in Figure 29. These values are determined depending on the amount of purge material that is fed to the cement making process, and thus strongly influenced by the feeding rate of the make-up stream. It comes apparent, that higher replacement rates are favorable in terms of  $\text{CO}_2$  capture efficiency, since more limestone is calcined in the oxy-fired calciner of the CCL unit. The specific  $\text{CO}_2$  emissions, for the two different integration cases (I: flue gas extraction after cyclone pre-heating, II: flue gas extraction between 3<sup>rd</sup> and 4<sup>th</sup> pre-heater and fed back in 3<sup>rd</sup> pre-heater) are compared in Figure 29. Both resulting curves show a similar pattern. Higher raw meal substitution leads to lower specific  $\text{CO}_2$  emissions. This is due to the increasing share of limestone that is calcined under oxy-fuel combustion conditions in the calciner, and thus all released  $\text{CO}_2$  is captured directly.

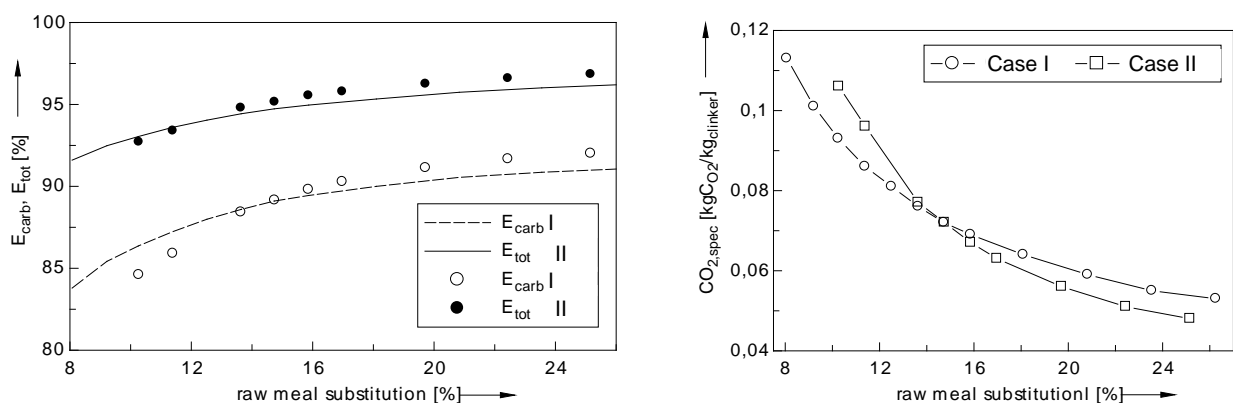

**Figure 29: Comparison of carbonator  $\text{CO}_2$  absorption efficiency and total capture efficiency depending on the raw meal substitution (left) and specific  $\text{CO}_2$  emissions (right) for integration cases I and II**

### Thermodynamic evaluation of CCL for an integrated steel mill

In this study, the CO<sub>2</sub> absorption rate of 90 % is achieved within the carbonator. The thermal duty of the calciner, and the additional electricity that is generated ( $P_{el,gross}$ ,  $P_{el,net}$ ) are depicted in Figure 30. Along with a higher sorbent loading, as achieved by longer residence times of the particles within the carbonator, more heat is required in the calciner for calcination of the incoming sorbent. In parallel, the power output of the power cycle as attached to the CCL unit increases as well. The auxiliary demand includes the power consumption of the ID fans within the CCL system, the ASU consumption and the CO<sub>2</sub> compression system. The latter represents the greatest share of the total auxiliary consumption of the CCL system (around 53 %).

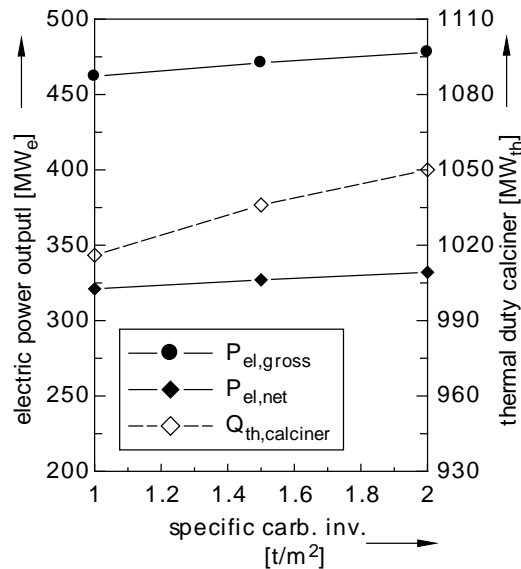

Figure 30: Thermal input and electricity generation of the CCL integration case

### Economic evaluation of CCL for a cement plant

For the base case (without CCL integration) the cement plant has an average of 748 kg CO<sub>2</sub>/t clinker produced. Integrated with the CCL the cement plant is capable of removing around 90% of the CO<sub>2</sub> from flue gases, resulting in CO<sub>2</sub> emissions of 82.2 kg CO<sub>2</sub>/t clinker.

The total capital cost for the reference plant is estimated at €422 millions. If the project design, construction, commissioning time and contingency are included the total capital investment increases to €528 millions. If the load factor for cement production is assumed to be 88%, the levelised cost of €74/t Cement is calculated.

For the integration case, total capital costs increase from €528 millions to €946 millions against the base plant due to the additional CCL plant cost and 'Secondary Steam Cycle' being introduced. For the plant to have a zero NPV over the lifetime, the levelised cost of €92.5/t cement is required.

Based on the above case study, the cost of CO<sub>2</sub> captured and the cost of CO<sub>2</sub> avoided relative to the corresponding reference plant are €15.8/t CO<sub>2</sub> and €27.6/t CO<sub>2</sub>, respectively.

### Task 6.3.2 - Economic evaluation of CCL for an integrated steel mill

For the base case (without CCS) the ISM has an average of 1156 kg CO<sub>2</sub>/t HRC produced. Integrated with the CCL the ISM is capable of removing around 90% of the CO<sub>2</sub> from flue gases, resulting in CO<sub>2</sub> emissions of 185 kg CO<sub>2</sub>/t HRC.

Based on the information provided by the reports [4,5] the total capital cost of €155 millions for the reference ISM is estimated. If the project design, construction, commissioning time and contingency are included the total capital investment increases to €370 millions. If the load factor for the ISM is assumed to be 100%, the levelised cost of of €434/t HRC is calculated.

For the integration case, total capital costs increase from €370 millions to €133 millions against the reference ISM due to the additional CCL plant cost and ‘Secondary Steam Cycle’ being introduced. For the plant to have a zero NPV over the lifetime of the levelised cost of €459.7/t HRC is required.

Based on the above case study, the cost of CO<sub>2</sub> captured and the cost of CO<sub>2</sub> avoided relative to the corresponding reference ISM are €12.6/t CO<sub>2</sub> and €6.5/t CO<sub>2</sub>, respectively.

### Environmental assessment – Cement Plant

A life cycle analysis (LCA) was completed to evaluate the environmental impact of calcium carbonate looping (CCL) technology integrated with a cement plant. The study is a comparison between a cement with and without the CCL. The function of the process is to produce clinker. In agreement with other similar studies, the functional unit is the production of 1 tonne of clinker [6, 7]. The environmental impacts of the plant technology and its potential hazards to human, wildlife, and bio-systems are considered. The reference flow is 1 tonne of clinker. The LCA was carried out using the ReCiPe methodology and both the midpoint and endpoint were considered. SimaPro 8.3 was used to model the system. The endpoint damage assessment results are shown in Figure 31.

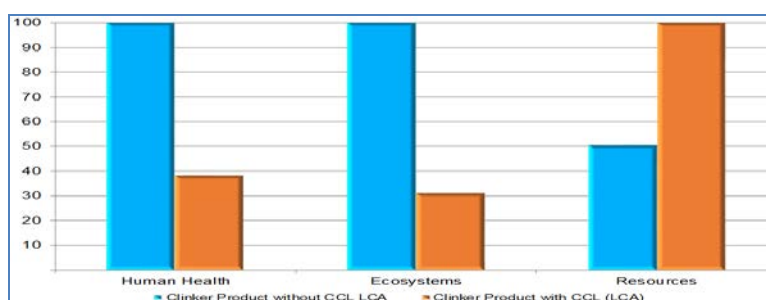
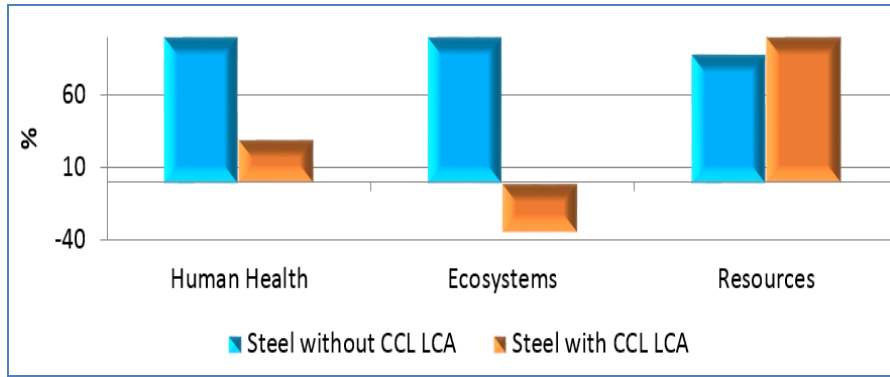

**Figure 31: Comparing cement plant with and without CCL**

The endpoint analysis indicates that producing clinker has a lower environmental impact with the employment of the CCL as a decarbonisation tool than without the CCL. The damage assessment results indicate a 62% and 69% reduction in potential impact for the human health and ecosystems indicators respectively. This is achieved via a 49% increase in the resource indicator. Some impact categories are lowered by the integration of CCL with the CP and others are higher. This is to be expected as the CCL plant consumes resources to function. One reason for a reduction in impact in the terrestrial acidification, photochemical oxidant formation and particulate matter formation impacts is the further reduction of sulphur dioxide (SO<sub>2</sub>) by the formation of calcium sulphate (CaSO<sub>4</sub>) within the CCL process. Other impacts are reduced due to the avoided products; electricity, during the CCL process. The increase in some impacts is due to the increase in resource extraction and use. The increase of these impacts has to be balanced against a 78% reduction in the climate change impact.

### Environmental assessment – Integrated steel mill (ISM)

A life cycle analysis (LCA) was completed to evaluate the environmental impact of calcium carbonate looping (CCL) technology integrated with the ISM. The study is a comparison between a steel plant with and without the CCL. The endpoint damage assessment results are shown in Figure 32.

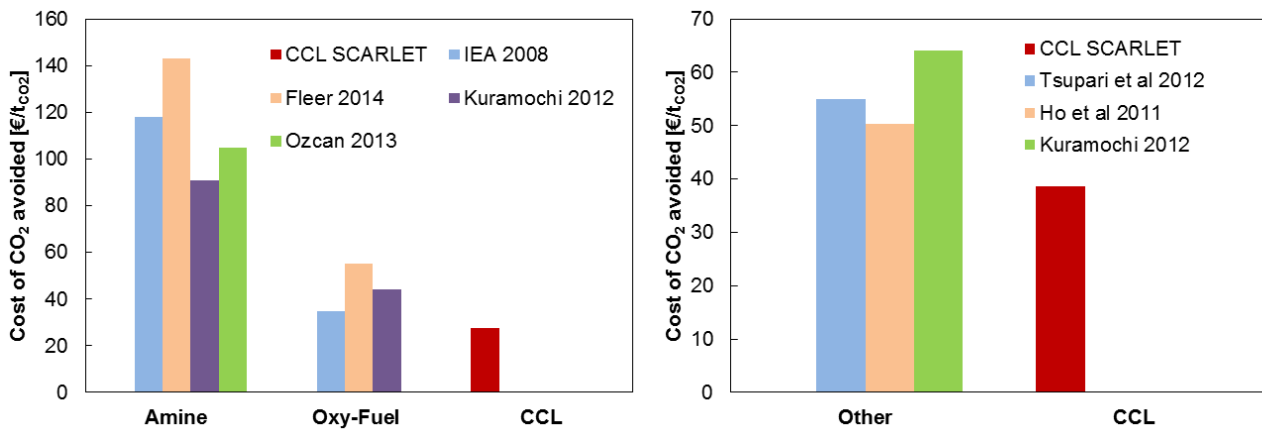

**Figure 32: Comparing steel plant with and without CCL**

The end-point analysis results indicate that producing hot rolled coil has a lower environmental impact with the CCL than without the CCL. The damage assessment indicates a 70% and 132% decrease in the impact scores of human health and ecosystems and an increase in the resource impact of 12%. The mid-point results show that a number of impacts are low; even in the reference case with no CCL. However, the power plant integrated into the steel plant, nominally powers two steel plants including the downstream processes that are not included in the boundary of this study. Therefore, the power usually consumed by the second power plant and the finishing process stages, is treated as an avoided product.

### Conclusion

The evaluation of economics and the comparison to other CCS technologies show the advantages of CCL. The CO<sub>2</sub> avoidance costs are significantly lower compared to other technologies (see Figure 33). Especially for the cement industry, the results clearly show the lowest CO<sub>2</sub> avoidance costs compared to amine scrubbing and oxy-fuel technology resulting in a main advantage of the CCL technology. This is a result of the synergies using the same feedstock limestone for both processes leading to advantageous economics compared to other technologies.



**Figure 33: Comparison of CO<sub>2</sub> avoidance costs for cement and steel plants**

### Overall Conclusions

The CCL process has successfully been tested in 1 MW<sub>th</sub> scale at realistic conditions reaching steady state in terms of operating conditions and sorbent properties under a wide range of parameters. A comprehensive data base including solid samples and in-furnace measurements has been accomplished for evaluation of the CCL process. Rather low calciner flue gas recycling rates corresponding to O<sub>2</sub> inlet concentrations of at least 50 % are feasible. The flow of make-up limestone to the process strongly affects the activity of the sorbent and, therefore, the CO<sub>2</sub> capture efficiency. Furthermore,

the type and particle size of the coal introduced to the calciner has a significant effect on sorbent properties. Coarse grained coal leads to an accumulation of ash in the circulating sorbents, whereas a high Sulphur content promotes the formation of gypsum. All in all, an operation window with total CO<sub>2</sub> capture efficiencies of 90-95 % has been defined.

The data base from 1 MW<sub>th</sub> testing has been utilized to develop and validate tools for scale-up of the process and reactor design. Process models enable the determination of heat and mass balances either in steady-state conditions for the prediction of the overall performance or in dynamic mode for the evaluation of the load flexibility of the plant. An advanced reaction model considering effects of sintering, sulphation and steam is decisive for the calculation of the CO<sub>2</sub> absorption rate. CFD models allow the simulation of the 3D flow field inside the reactors. Here, an appropriate drag model, such as EMMS, is important for an accurate prediction of the gas-solid flow in the CFB reactors. In general, good agreement between measurements and simulations has proven the reliability of these models.

The full-scale application of the CCL process to power, cement and steel plants has been evaluated in terms of efficiency, economics and environmental impact using scaled process models. A net efficiency loss in a range of 6-7 %-points (including CO<sub>2</sub> compression) for hard coal and lignite fired power plants combined with very competitive CO<sub>2</sub> avoidance costs of 20-27 €/per tonne CO<sub>2</sub> show substantial advantages compared to other CO<sub>2</sub> capture technologies. The integration of CCL in cement plants is of particular interest since a) spent sorbent can be directly utilized as raw material for the clinker production leading to significantly lower CO<sub>2</sub> avoidance costs than amine scrubbing, and b) process CO<sub>2</sub> released during calcination of raw meal can only be avoided by CO<sub>2</sub> capture. Life cycle analyses conclude that the environmental burden of power and industrial plants can be significantly reduced by a CCL retrofit.

As the next step towards commercialization of CCL technology, a 20 MW<sub>th</sub> pilot plant has been designed based on heat and mass balances created for various load cases. The design and operational performance of the reactors have been confirmed by CFD simulations. No risks with respect to health, safety, environment, and technological development have been identified that would be considered unmanageable. The investment cost (CAPEX) and operational cost (OPEX) have been estimated.

Despite the advantages of the CCL process compared to other CO<sub>2</sub> capture processes, the realization of a 20 MW<sub>th</sub> pilot plant is considered as a commercial risk since there is currently no business case for full-scale application of CCS in general. Legislation - in Europe and most parts of the world – is far behind what is needed to give an environment that allows roadmaps for CCS to be developed. There have to be incentives to invest in CCS technologies as the current price level of CO<sub>2</sub> and cost for CO<sub>2</sub> emissions is far too low. Major utilities or industrial installations may only be upgraded with CCS if there is a reliable sink for the captured CO<sub>2</sub>.

### References

- [1] J. Ströhle, M. Junk, J. Kremer, A. Galloy, and B. Epple, "Carbonate looping experiments in a 1MW<sub>th</sub> pilot plant and model validation," *Fuel*, vol. 127, pp. 13-22, 2014.
- [2] I. Martínez, G. Grasa, R. Murillo, B. Arias, and J. C. Abanades, "Kinetics of Calcination of Partially Carbonated Particles in a Ca-Looping System for CO<sub>2</sub> Capture," *Energy & Fuels*, vol. 26, pp. 1432–1440, 2012.
- [3] E. Muschelknautz, "Die berechnung von zyklonabscheidern für gase," *Chemie Ingenieur Technik*, vol. 44, pp. 63-71, 1972.



- [4] IEA Greenhouse Gas R&D Programme (IEA GHG), Assessing the potential of implementation CO<sub>2</sub> Capture in an integrated steel mill, August 2011.
- [5] IEA Greenhouse Gas R&D Programme (IEA GHG), Iron and Steel CCS Study (Technoeconomics Integrated Steel Mill) 2013/04, July 2013.
- [6] D. García-Gusano, D. Garraín, I. Herrera, H. Cabal and Y. Lechón, “Life Cycle Assessment of applying CO<sub>2</sub> post-combustion capture to the Spanish cement production,” *Journal of Cleaner Production*, vol. 104, pp. 328-338, 2015.
- [7] F. Stafford, F. Raupp-Pereira, J. Labrincha and D. Hotza, “Life cycle assessment of the production of cement: A Brazilian case study,” *Journal of Cleaner Production*, vol. 137, pp. 1293-1299, 2016.

## 1.4 Impact

SCARLET has taken a significant step towards maturity and commercialization of one of the most promising CO<sub>2</sub> capture technologies. Demonstrating the process in 1 MW<sub>th</sub> scale at realistic operating conditions, developing and validating various scale-up tools resulting in the comprehensive design and engineering of 20 MW<sub>th</sub> pilot plant prepared the ground for taking the next steps in pre-commercial demonstration of the technology. SCARLET is in line with the demand of rapid development of post-combustion CO<sub>2</sub> capture technologies addressed in the European Union's Strategic Energy Technology (SET) Plan. The technology investigated in the SCARLET project helps to fulfil the objectives of the European Union demanding for reduced costs and energy penalties of CO<sub>2</sub> capture technologies. SCARLET has acquired the following innovative contributions:

- Long-term operation of a 1 MW<sub>th</sub> pilot scale calcium carbonate looping CO<sub>2</sub> removal system achieving high performance at high operability (various fuels, solid material, operating parameters etc.)
- Development of various validated simulation models and criteria for the scale-up to the next road map step of 20 MW<sub>th</sub> equivalent size
- Design and engineering of a 20 MW<sub>th</sub> pilot plant including operating procedures, health, safety and risk analyses showing no unmanageable risks as well as a calculation of investment and operational costs preparing the basis for pre-commercialisation of the CCL technology
- Integration of CCL in commercial oriented power plants, in a steel plant or in a cement plant to optimize performance and minimize technical risks, targeting efficiency, reliability and operability
- Economic assessment of CCL giving credibility to the technology of lower costs of CO<sub>2</sub> capture within the target values established by the European Union
- Environmental assessment confirmed its environmental credentials as compared to conventional CO<sub>2</sub> capture techniques.

The project has strengthened the position of Europe as the key driver of the CCL technology. In particular, the long-term demonstration of the CCL process at 1 MW<sub>th</sub> scale under realistic operating was a milestone in the development of this technology. The application of this technology for power production will preserve and create jobs in the European market concerning technology development and energy supply, as well as by the cement and steel industry. The practical commercial application of its results, with the primary objective of fighting climate change and protecting the environment, will also support the European economy. Especially the export of CCL technology to countries worldwide relying on fossil based power generation and demanding for CCS technologies will be a great chance. The lead for the realization of this purpose is taken by European entities, thereof two major power companies as well as cement and steel companies in the consortium. The benefits seen in the CCL process by the consortium are multiple: two of the most important are the lower cost of CO<sub>2</sub> avoidance and additional power generation of a retrofitted power plant with respect to other capture processes.

A main target addressed in the project was the long-term operation in 1 MW<sub>th</sub> scale under realistic operating conditions, such as realistic flue gas and oxy-combustion in the calciner. The variation of the type of fuel (hard coal, lignite in various particle size distributions), the sorbent, flue gas composition, reactor design, reactor temperatures, make-up flow, solids circulation flow etc. were used to obtain reliable data about the process performance in order to scale-up the process. Noteworthy to be

mentioned is the fuel flexibility of the fluidized bed calciner, given for the operation of a retrofitted CCL plant for power plants. The process is suitable for a wide range of coal, proven by the pilot tests. As a consequence, the technology provides the option of feeding a wide range of fuels to the process, e.g. local European coals, biomasses or alternative fuels like refuse derived fuel. Therefore, the CCL technology would reduce the dependency on fuel imports and provides an additional application for biomass co-combustion and utilization of waste.

SCARLET brings CCL technology to the next level of maturity, preparing the ground for pre-commercial demonstration of this promising technology. The results give confidence for investments into a larger-scale 20 MW<sub>th</sub> unit facilitating the design of a future large-scale demonstration project, aiming at short term commercialization of the process. The cost estimate provides a sound basis to start a discussion between the various stakeholders (universities and research institutes, industrial partners and funding organizations) on how to finance and realize this essential next technology development step. The health and safety risk assessment as well as technical risk analysis done identified potential risks, allowed to develop related mitigation plans and thus increased confidence level for realization of the 20 MW<sub>th</sub> pilot plant. The further implementation of the results shall lead to the construction of the planned 20 MW<sub>th</sub> pilot in collaboration with a power plant owner or other industrial partner in a follow-up project. The proposed 20 MW<sub>th</sub> scale pilot plant will be an important step towards commercialization of the technology.

The economic assessment is of great concern comparing the technology to other CCS processes. The criteria developed by the European Benchmarking Taskforce were applied for the thermodynamic and economic evaluation of the CCL technology for various host power and industrial plants. The results for power plant retrofits show a significant reduction of the energy penalty to 6-7 %-points, lower CO<sub>2</sub> avoidance costs in a range of 20-27 €/per tonne of CO<sub>2</sub> (MEA/oxyfuel 40-70 €) and a smaller increase of costs of electricity (CoE) of 20-40% compared to 1<sup>st</sup> generation capture technologies. A significant advantage is the fact that the CCL technology repowers existing power plants by recovering the heat generated in the CCL process by an additional highly efficient water/steam cycle. In contrary to other technologies where the power output is significantly decreased, additional power is added to the grid to cover additional power demand in Europe by a carbon clean technology.

Of particular interest is the application of the CCL technology in industrial processes like steel or cement production. Industrial installations are generally smaller in size compared to power plant applications. Therefore smaller size designs retrieved during the development of the large scale power plant CCL technology are already transferable into industrial solutions. Existing infrastructure and other process equipment in terms of cement application can be used, thus minimizing the expenditures for the total installation. Additionally, purged sorbent of CCL application can be utilized in industrial processes. Analyses carried out in the course of the project, show promising results for reutilization in the cement/clinker manufacturing process. The CO<sub>2</sub> avoidance cost around 43 €/per tonne of CO<sub>2</sub> show significant technical and economic advantages of these synergies.

#### **1.4.1 Dissemination activities**

The SCARLET consortium was aware of the importance of disseminating the efforts taken and results obtained in the project in the field of CCS. Thus, strong efforts have been taken to distribute and exploit the results during the whole project period. A summary of the main dissemination activities carried out:

- Website
- 4 publications in scientific journals have been placed, additional publications in scientific journals (7) and conference proceeding (5) are in preparation (5 promised in the proposal)

- 17 presentations, thereof oral (14) and poster (3), in international conferences have been held
- 2 publications in other scientific magazines
- 4 industrial oriented newsletters
- 2 public workshops presenting the results of the project and providing the opportunity to visit the 1 MW<sub>th</sub> pilot plant
- More than 13 appearances in newspapers, TV and internet
- 3 Public Reports
- Regularly updated Technology Implementation Plan
- Exploitation Report

The SCARLET **website** [www.project-scarlet.eu](http://www.project-scarlet.eu) has been developed and is regularly being updated by TU Darmstadt. The main objective of the website is to communicate the objectives and results as wide as possible, targeting the scientific community and the public. Additionally, the website operates as the project's repository for public documents. The main information contained in the website includes:

- Information about the SCARLET project and its activities including contact details, participants, main objectives, brochure, background information, a plant description and events (workshops, conferences)
- Results obtained during the project, including summary of all scientific publications (peer-reviewed journal papers, conference proceedings and presentations at conferences)
- Photos and videos of the pilot plant
- Frequent news and updates on the public material
- Public Deliverables

Every six months, a **newsletter** giving news about project developments is produced and disseminated to all relevant stakeholders who register their interest at the website. In October 2014, the first issue of the SCARLET newsletter was disseminated to interested stakeholders. Three additional newsletters in June 2015, April 2016 and February 2017 followed.

The high number of **scientific publications** and presentations at **international conferences** shows the relevance of the SCARLET project. A complete list can be found in Chapter 2 of this report.

During the course of the SCARLET project, two **public workshops** were organized to inform relevant stakeholders about the results of the project. Stakeholders were notified by email and through the website – energy engineers, utilities, academia and research institutions, industry, consultants and general public. The 1<sup>st</sup> Public SCARLET Workshop on 20<sup>th</sup> April 2016 at TUD presented the results of the first phase of the project focusing on the long-term pilot testing of the CCL process and the development and validation of scale-up tools: process and 3D-CFD models. J. C. Abanades (Spanish Research Council CSIC-INCAR) presented the results from CCL testing in the La Pereda pilot plant as an invited guest speaker. The 2<sup>nd</sup> Public SCARLET Workshop on 23<sup>rd</sup> March 2017 at TUD focused on the results of the second phase of the project focusing on the scale-up and engineering of a 20 MW<sub>th</sub> pilot plant including CFD simulations of the up-scaled pilot plant reactors. Integration sce-



As a highlight, carbonate looping technology and the SCARLET project were also presented in the Hessenschau of the Hessian Broadcasting Service (HR) in a TV spot called “Hessische Innovation für den Klimaschutz”. The public was addressed to explain the technology and its advantages. The video of the article can be accessed on the website (“Publications”) or with the following link:

[http://www.est.tu-darmstadt.de/images/stories/video/20150110\\_Hessenschau\\_720x576.ogv](http://www.est.tu-darmstadt.de/images/stories/video/20150110_Hessenschau_720x576.ogv)

Three **public reports** were released at the end of each project year (March of 2015, 2016 and 2017). Each public report contains a summary of the major results obtained by the project within the preceding 12 months. Electronic versions of the public reports are available for download on the website and were sent by email to any interested stakeholder. The target audience of the public reports includes researchers, industry representatives, technology developers, potential investors, regulators and policy makers.

During the course of the project, a **Technology Implementation Plan** was jointly elaborated by the partners summarizing the results and describing the further collaboration, dissemination and use of these. The Technology Implementation Plan was updated every six month considering the latest results of the ongoing project workload. All updates of the Technology Implementation Plan are available for download from the public website.

The exploitation of results was summarized in an **Exploitation report and revised exploitation plan**. The Exploitation report and revised exploitation plan is available for download from the public website.

#### 1.4.2 Exploitation of results

A very valuable and consistent set of experimental data at semi-industrial pilot scale has been obtained and a huge operational experience based on the pilot tests has been gained. The developed simulation tools developed in the project have been validated with this data and the results and experiences from pilot testing were used to design and engineer a 20 MW<sub>th</sub> pilot plant. The information (pre-engineering, technical and safety risk assessment, cost estimation) is valuable for the future realization of the CCL technology and the scale-up of the process towards commercial scale.

The results from pilot testing and model development and validation is being presented at scientific conferences and published in peer-reviewed journals. Furthermore it will be used as a basis for doctoral theses and in lectures at Technische Universität Darmstadt. The models developed will be further enhanced and applied for various fluidized bed-based processes, e.g. chemical looping combustion, oxy-fuel combustion etc. The beneficial use of advanced computation tools like CFD will be advertised. The intention is to attract operators and engineering companies to further invest in the development of this tool and/or solve their issues in specific areas of their processes using CFD.

The vast comprehensive experience obtained from operating an interconnected circulating fluidized bed system will be applied to other emerging fluidized bed-based (CO<sub>2</sub> capture) technologies, e.g. chemical looping combustion. It is intended to operate the upgraded pilot plant in further testing of the CCL technology, e.g. with refuse derived fuel (RDF) or under conditions for cement application.

Plant and utility operators are making use of the results for comparative purposes. Some intend to do internal benchmarking of different CO<sub>2</sub> capture technologies in order to identify the most economical solution for their business.

The publishing of the works in conferences and peer-reviewed articles advertises not only the technology but also the tools and methods used. This dissemination is expected to support also marketing objectives for plant engineering companies by an increased level of awareness on the client side.

Despite all the activities to expedite commercialization mentioned before, the full commercial exploitation is considered at risk. Legislation - in Europe and most parts of the world – is far behind what is needed to give an environment that allows roadmaps for CCS to be developed. Common understanding of the consortium partners is that there have to be incentives to invest in CCS technologies as the current price level of CO<sub>2</sub> and cost for CO<sub>2</sub> emissions is far too low. Major utilities or industrial installations may only be upgraded with CCS if there is a reliable sink for the captured CO<sub>2</sub>.

Therefore, the outlook regarding future commercialization from plant and utility operators, engineering companies but also from academia point of view is rather uncertain. Forecasts or detailed exploitation plans cannot be made as there is a too high degree of uncertainty in the market. Nevertheless, CCL is low-cost post-combustion CO<sub>2</sub> capture technology that has been successfully demonstrated in semi-industrial scale. The ground for scale-up of this technology is prepared to contribute to the reduction of CO<sub>2</sub> emissions in various power and industrial applications.



## 1.5 The address of the project public website and contact details

Homepage: [www.project-scarlet.eu](http://www.project-scarlet.eu)

Coordinator contact: Dr.-Ing. Jochen Ströhle  
+49 6151 16-23003  
[jochen.stroehle@est.tu-darmstadt.de](mailto:jochen.stroehle@est.tu-darmstadt.de)

M. Sc. Jochen Hilz  
+49 6151 16-22679  
[jochen.hilz@est.tu-darmstadt.de](mailto:jochen.hilz@est.tu-darmstadt.de)

Institute for Energy Systems and Technology  
Technische Universität Darmstadt  
Otto-Berndt-Str. 2  
DE-64287 Darmstadt

GECC: Olaf Stallmann  
+49 6134 712 472  
[olaf.stallmann@ge.com](mailto:olaf.stallmann@ge.com)

GE Carbon Capture GmbH  
Lorenz-Schott-Str. 4  
DE-55252 Mainz-Kastel