

AIR PROJECT

Active and Isolated Rectifier unit for more electric aircraft: Design and Manufacturing of a 10KW AC-DC Converter Unit



This Project has been partially funded by the European Commission within the framework of Clean Sky Programme



Abstract:

This project, named as AIR (Active and Isolated Rectifier unit) and developed by the consortium Indra and CEI-UPM, answer the call of proposal presented by the “Topic Manager” inside of the call14 of the FP7 of the European Commission (“JTI-CS-2013-1-SGO-04-007: Design and manufacturing of a 10 kW AC-DC converter unit”).

In the frame of Clean Sky SGO, innovative aircraft electrical networks are developed in order to support the More Electrical Aircraft concept (MEA), and a new complete electrical architecture must be implemented and tested to answer the challenges of a high power network.

The foreseen electrical network will be demonstrated in SGO WP4.2 on a highly representative test rig where it is planned to reach Technology Readiness Level (TRL) 5 for main critical components.

One of the key axes to achieve a successful electrical distribution is the use of power converters to adapt the sources’ capabilities to the loads’ power requirements. As a consequence of a power rationalized aircraft, where electricity becomes the main power source for the aircraft systems, the use of different power converters is mandatory. To ensure high availability of electrical bus bars and so that dependence on a particular type of equipment cannot exist, it is foreseen to ensure power conversion dissimilarity to generate 28Vdc: DC/DC converters ($\pm 270\text{Vdc} / 28\text{Vdc}$) and AC/DC (230Vac / 28Vdc) converters will be used on the test rig. This choice allows electrical reconfiguration in case of failure in High Voltage Direct Current (HVDC) network, and ensures a double-separated-dissimilar 28Vdc power supply.

The use of transformer-rectifier units is state-of-the-art for current aircraft designs to accomplish this AC/DC power conversion. Nevertheless, for the future aircraft, weight and thermal optimization become critical; this means that a strong technological step must be performed from the current state of the art, which has not evolved during last years as fast as for other static converters. Current requirements for TRU (Transformer Rectifier Unit) have strongly challenged the capabilities of these equipment’s, marking

critical axes of improvements as the need of higher temperature components, filters design and noise. Taking into account these elements, the need of a complete redesign in all the aspects, is essential.

Consequently, the topology and the need of a control strategy (controlled converters vs. passive converters), shall be detailed studied to achieve the required expectations and ensure compliance of proposed design with aircraft requirements.

The AIR project tries to answer these challenges in the best way. So, the main actions and objectives of this project were:

- Perform a detailed comparison between several passive and active designs. The objective is to determine the best option in terms of electrical performances (as ripple, voltage and current harmonic distortion, inrush current, voltage slop, efficiency), noise and weight.
- Propose a design for a 10kW 230Vac-28Vdc converter, coherent with the study performed in the first task.
- Manufacture and test a TRL5 10kW converter prototype based in the previous assessment and design activities.

Moreover, during study and design phase, the possibility of implementing high temperature components shall be taken into account, as another solution to solve thermal challenges.

After in-house testing, a prototype will be integrated in a test bench representative of the MEA electrical network, so that further tests can be performed at level unit, and integration with AC network and 28Vdc network and batteries can also be evaluated.

INDRA and CEI-UPM, has a wide experience in the area of high performance electrical converters and work in a lot of aeronautical project (R&T&D and serial industrial projects) knowing about difficult and critical aircraft requirements, as high power quality, dimension and weight restrictions, in-flight environment and key drivers on safety, reliability and maturity aspects.

Previous Experience and initial work:

Previously to this project, the consortium already know about the challenges of improvement of the aircraft electrical network and performed a review of the state proposing some initial ideas to achieve initial objectives of this project.



Electrical architecture for high performance TRUs.



Isolated Three-Phase Rectifier.

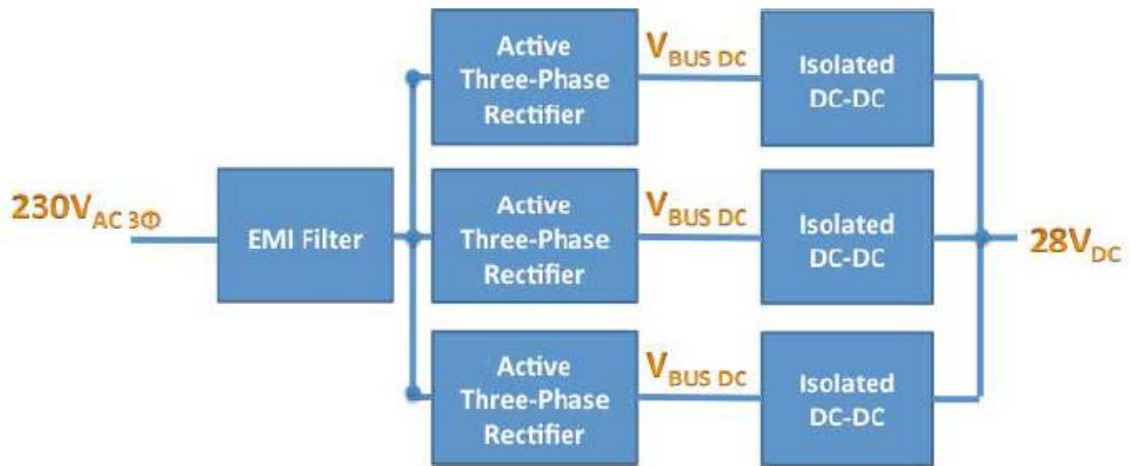

Interleaved of converters for high performance TRUs.

So a 1.5kW/kg active converter based in an EMI filter + AC/DC + isolated DC/DC was proposed and initially supported by previous works in Indra and CEI-UPM. This proposal was based on the experience in previous project, and it is a goal beyond of the state of the art (about +20% or +25% higher power/weight ratio). It is doable thanks to the use of high frequencies combined with soft switching techniques. Besides, the use of new SiC and GaN semiconductors will be analyzed and consider in the design since they allow for higher temperature operation as well as higher frequencies.



10kW TRU (INDRA and CEI-UPM): Three interleaved rectifiers.



10kW TRU (INDRA and CEI-UPM): EMI filter.

The basic architecture that allows for these high performance TRUs has three stages: 1) EMI filter to meet the EMI standards, 2) Active Three-Phase rectifier to control the demanded sinusoidal current (THD and PFC) as well as control the output dc voltage ($V_{BUS DC}$) and 3) isolated dc/dc converter that provides galvanic isolation, adapts the voltage and power to the specifications (28V) and it can be in charge of some control capabilities (battery charge mode, voltage source mode, current source mode, some protections). Within this project, this basic architecture will be considered and compared with the multiphase solution (several converters shifted and operating in parallel) as well as some active and isolated rectifiers proposed in the state of the art. For the isolated dc/dc stage, advanced topology solutions with soft transitions will be analyzed since they allow operating at higher frequencies, reducing the weight of the final unit. A topology recently proposed by UPM-CEI [*] is really appropriate for this application since it presents almost zero switching losses.

[*]: Pavlovic, Z., Oliver, J. A., Alou, P., Garcia, O., & Cobos, J. A. "Bidirectional multiple port dc/dc transformer based on a series resonant converter". , 2013 Twenty Seventh Annual IEEE Applied Power Electronics Conference and Exposition APEC (2013).

The first period of this project was based in the study of the electrical requirements requested for new and future aircrafts with more strict electrical requirements (bigger power and Power/Weight ratio, higher electrical parameters quality, same or better safety/reliability/maturity).

After recollection of this big quantity of requirements and its analysis, a matching over the different traditional or new power topologies (as in passive mode, active mode or mix mode) was done to select optimum topology for this concrete application.

The "Topic Manager" validation, it was decided to consolidate this part as key driver, to avoid that design selected under specific conditions to achieve TRL5/TRL6 could be finally not totally suitable for industrial aircraft due to some other points not taken into account over the solution proposed (parameters, inputs,...). Recurrent experiences in previous projects have highlighted this risk (good laboratory prototypes but with critical blocking points, when necessary to extrapolate for in-flight or serial- industry equipment) and in consequence this aspect has been taken in more consideration.

The consortium reworked all its studies over all this set of parameters (including environment aspect, as lightning, components hidden failure mode and failure accumulation,...) and pre-selected two complete active topologies (based in back rectifier topology and in Vienna rectifier topology), although for final design solution was selected the Buck-rectifier topology as more confident versus safety aspect as high voltage failure and converter isolation mode, although Vienna-rectifier topology seemed most promising about final weight/dimensions.

The second period of this project started from the selected design in period-1 and performed the detail design over it. Then, 3D mechanical design was completed and modeling, layout and component placing design was performed. Several loops of redesign were done according to changes requested during the component manufacturing or buying or due to design recommendations during the layout phase.

Finally, power and control PCBs were manufactured and assembled during this period. Moreover and in parallel, detail mechanical and thermal analysis was done and linked to it, mechanical design was completed and exported for manufacturing. And at the end of this period, some of the mechanical parts were manufactured and available for assembly and use. All objectives of design and manufacturing were highly achieved and the maturity and quality gotten was very high and under aeronautical requirements of design and manufacturing.

The third period started with the finalization of debugging over the different subassemblies and starting of tests over these PCBs step by step. In parallel, control software was programmed with continuous adjustment and new functions and protections up to the end of the project.

When subassemblies were checked and stable, open loop tests were performed in parallel in both power stages, in Input stage (EMI filter + Buck Rectifier) and in output stage (DC/DC stage + Output rectifier + output filter).

After several adjustment and some redesign linked to noise coupling during open loop tests, coupling of both stages was done, covering complete range of power without major problems.

Then, control was adjusted again to allow closing the control loops. So, additional sensors were connected. Control loop was closed in several steps and with stages disconnected at the beginning and finalizing with both stages connected and covering complete range of power. No blocking points were found in this phase of the project. Moreover, several protections were implemented to ensure no destructive issues during these tests.

Finally, when the unit was working stable in all the power range and as in steady state as under transient conditions, the power stages were integrated inside of the equipment case, and wiring and interfaces finalized. To note that mechanical subassemblies were performed in parallel to be ready for the final integration. And when integration was completed, final integration tests were performed, covering all

power range and different steady state conditions and different transient conditions and some failure cases.

After the finalization of the project, the consortium will continue working in this prototype for evolution towards commercial product and customizations.

Expected results:

For period-1, Initial objective of detail analysis of power topologies has been achieved, although using more time than expected, but with more mature results and confidence for subsequent phases of this project. The consortium expect that the additional time used with help to reduce the risks of blocking points during manufacturing, test and implementation phases, in order to achieve complete project objectives and not only partially.

As first results that we want to share with the scientific community is that it is very important to consolidate initial phases of the project to ensure that challenge design or proposal are not finally blocking a project. Initial hypothesis reducing the number of parameter to study shall be done very carefully, in an optimum way to achieve R&D objectives, but at the same time ensure extrapolation of investigation results to the industrial work. And taking in mind that, each concrete application is a “different world”, especially in aeronautic where there are a lot of parameters, with big differences and most of the time faced between them.

Along Period-1 of the project, activities of State of the Art, analysis of requirement, pre-selection and details analysis of several topologies, equipment architecture and initial interface definition and pre-design of one topology was performed.

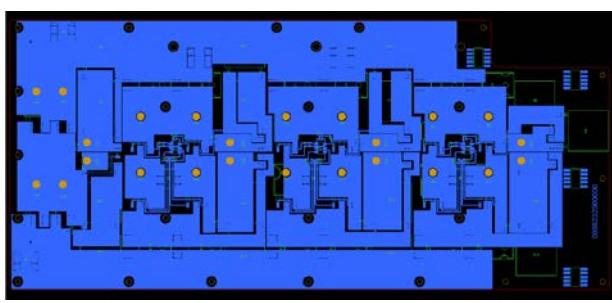
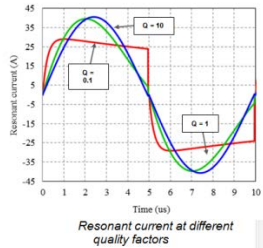
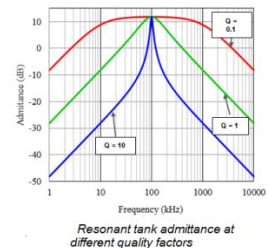
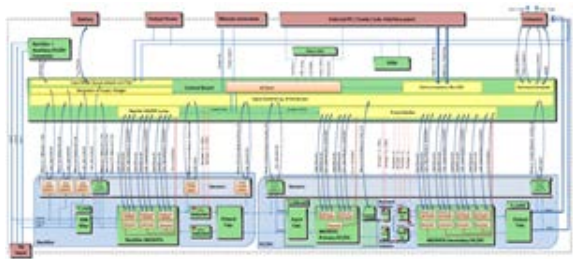

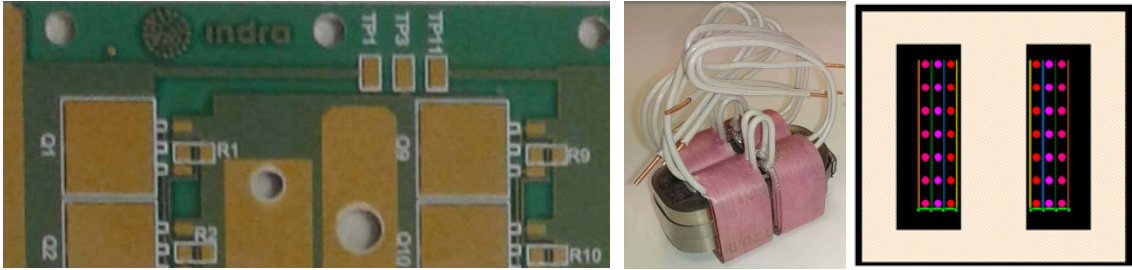

As commented before, for period-2, objectives of details design and manufacturing were gotten. Electric, electronic and mechanical design were done taking into account aeronautical requirements and quality process. Due to this, several restrictions were found with necessary additional loops of reworks. But this should ensure a better integration and avoid surprises during the testing phase.

For example, several changes over the way of power stages interconnection and power component driving were performed due to lessons learnt from internal previous projects or some others currently under testing phase.

Along Period-2 implementation of the selected topology including manufacturing off all PCBs and power components was performed and starting of the debug activity was performed.

According to this, at the end of the Period-2, the unit was ready to start tests.



Moreover, additional analyses in parallel about final improvement in cooling aspects and high temperature devices were performed along Period-2.

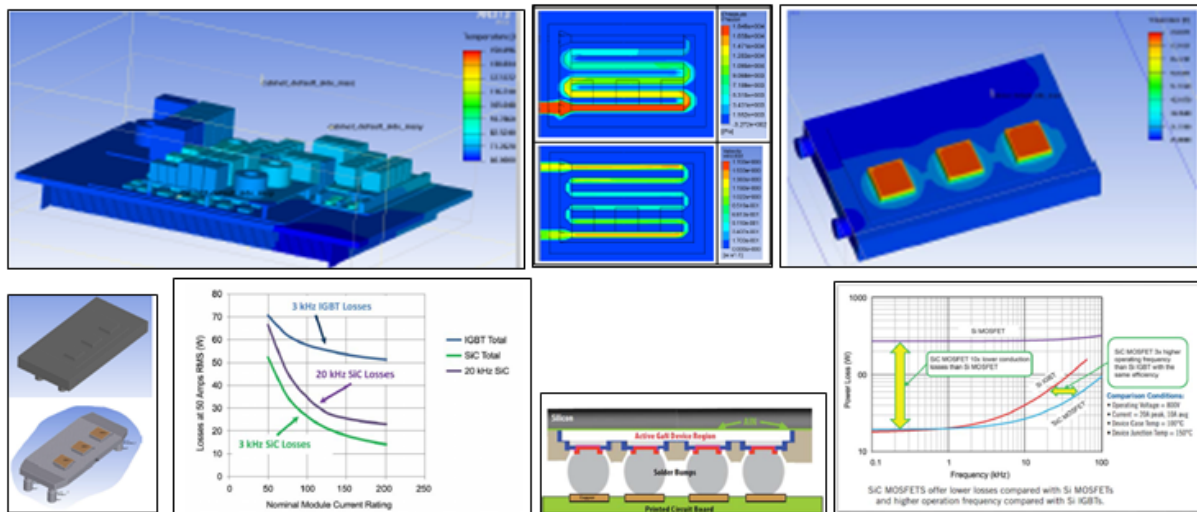

The third period started with the finalization of debugging over the different subassemblies and starting of tests over these PCBs step by step. In parallel, control software was programmed with continuous adjustment and new functions and protections up to the end of the project.

When subassemblies were checked and stable, open loop tests were performed in parallel in both power stages, in Input stage (EMI filter + Buck Rectifier) and in output stage (DC/DC stage + Output rectifier + output filter).

After several adjustment and some redesign linked to noise coupling during open loop tests, coupling of both stages was done, covering complete range of power without major problems.

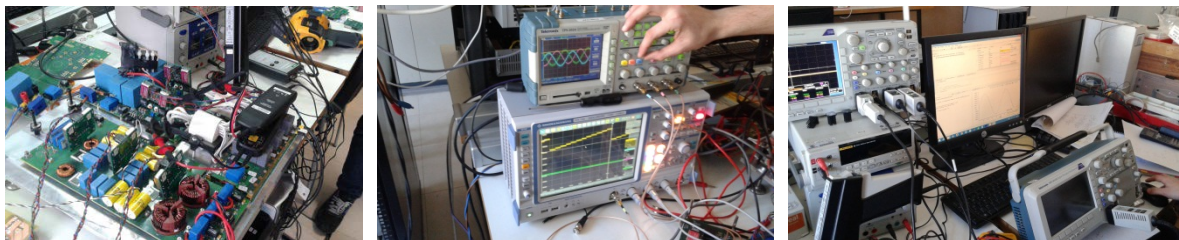

Then, control was adjusted again to allow closing the control loops. So, additional sensors were connected. Control loop was closed in several steps and with stages disconnected at the beginning and finalizing with both stages connected and covering complete range of power. No blocking points were found in this phase of the project. Moreover, several protections were implemented to ensure no destructive issues during these tests.





Finally, when the unit was working stable in all the power range and as in steady state as under transient conditions, the power stages were integrated inside of the equipment case, and wiring and interfaces finalized. To note that mechanical subassemblies were performed in parallel to be ready for the final integration. And when integration was completed, final integration tests were performed, covering all power range and different steady state conditions and different transient conditions and some failure cases.



After the finalization of the project, the consortium will continue working in this prototype for evolution towards commercial product and customizations.



**** Information updated at July 2016.****

Project Website:

<http://www.airprojectindra.info/>