

Project 641539: Micro-IMU

Final Report

ANNEX

Fig. 1: Block structure of the MEMS-based accelerometer for detection of wing deformations

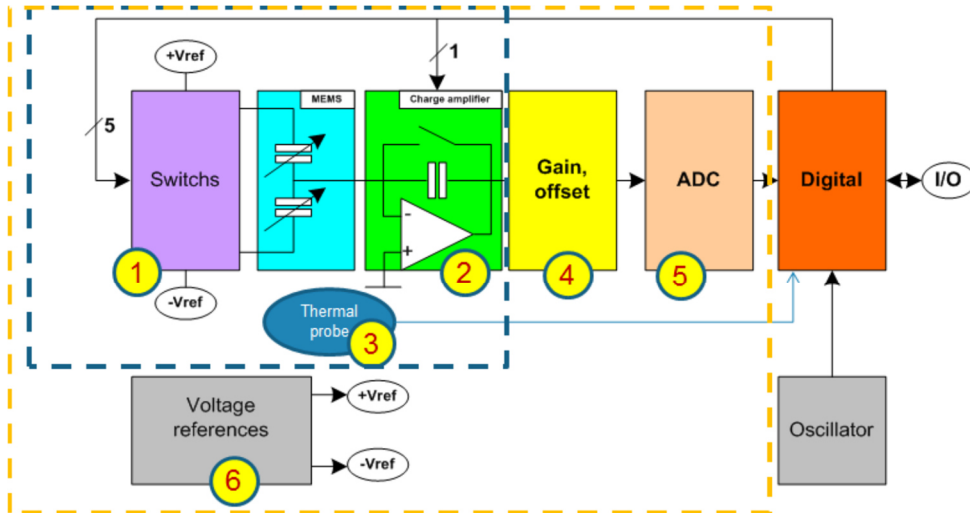

Fig. 2: Power supply

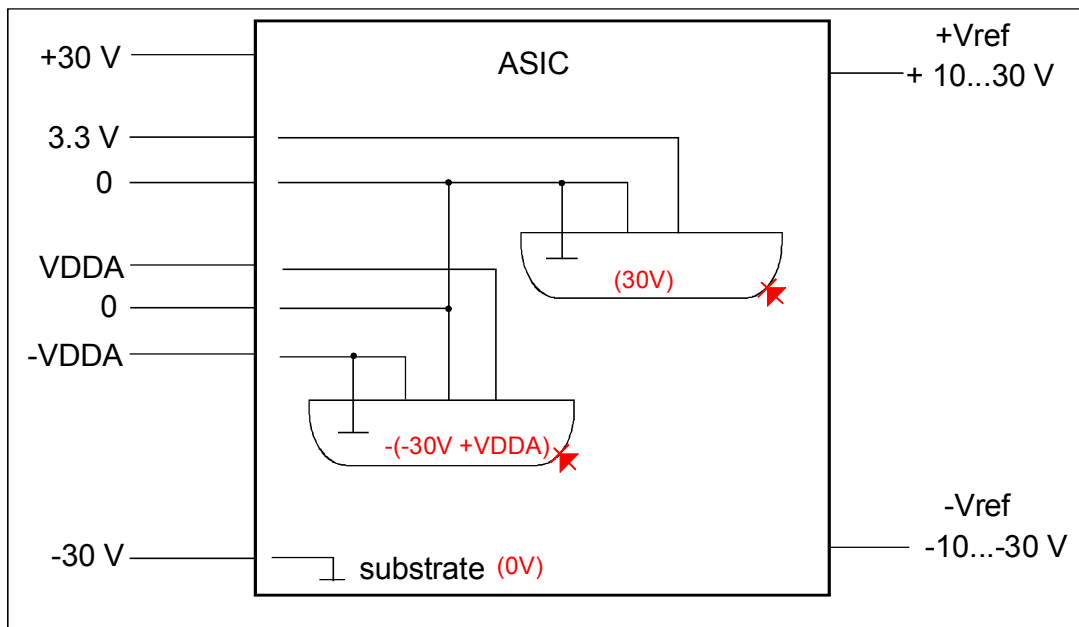

Fig. 3: Block structure of the switch unit

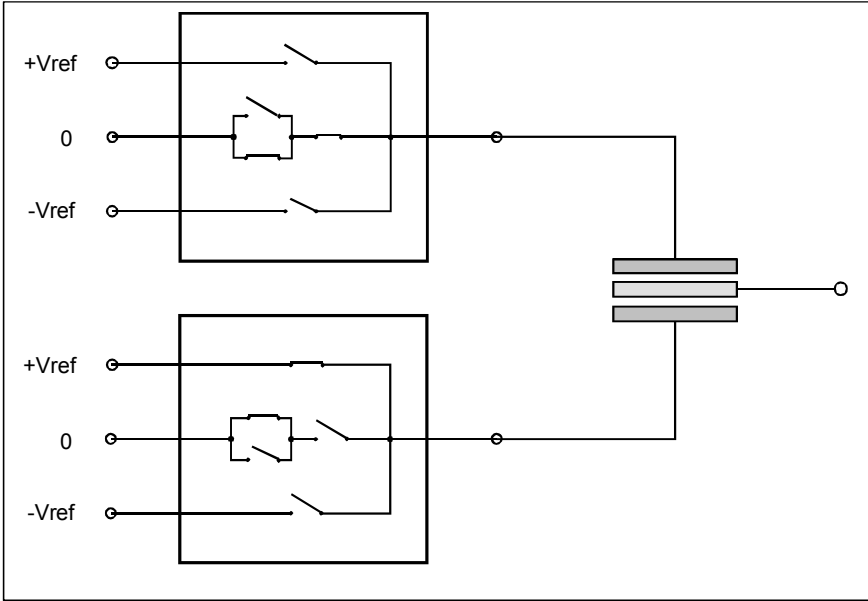

Fig. 4: ASIC A1 - Functional block diagram

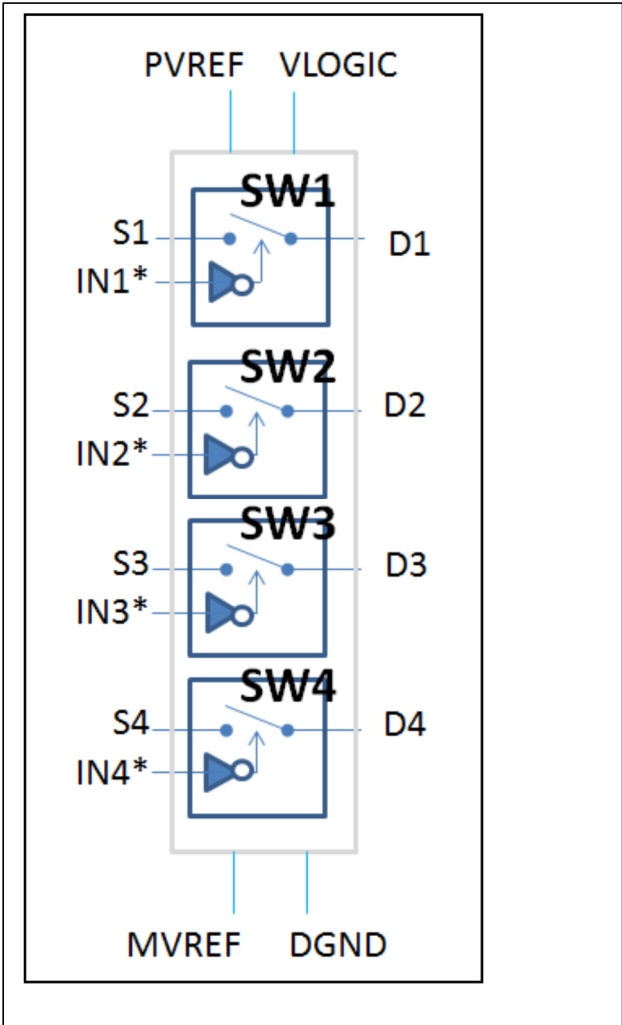

Fig. 5: ASIC A1 – Layout

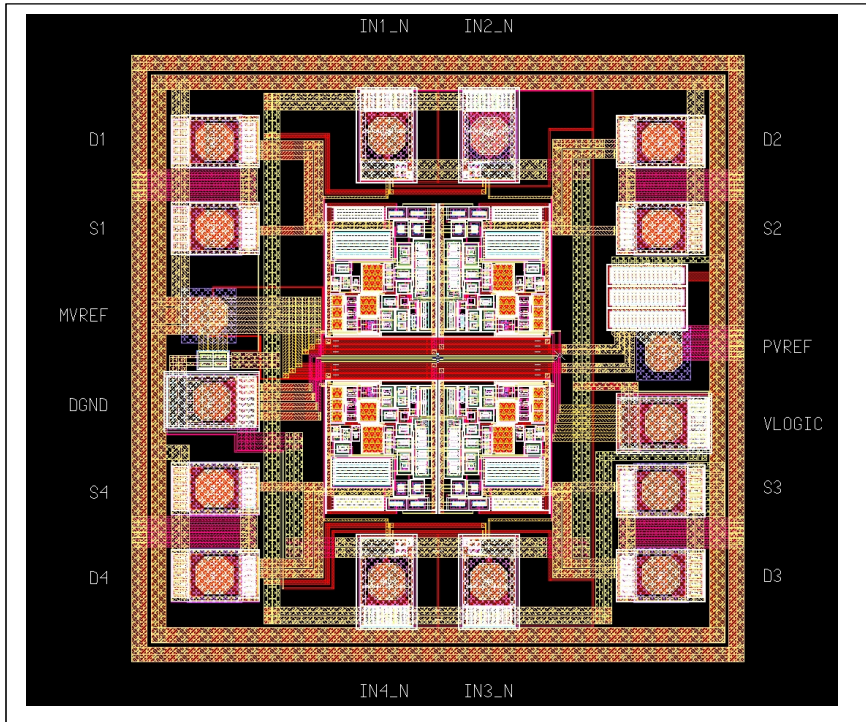

Fig. 6: ASIC C - Floorplanning

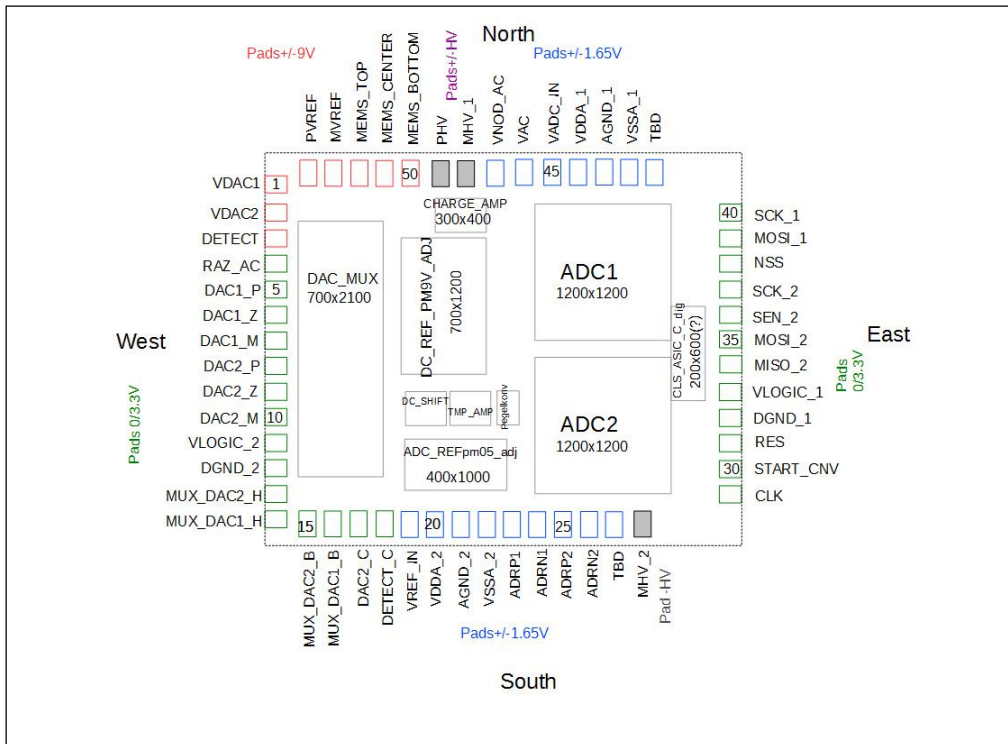

Fig. 7: ASIC C – Final layout

